

MODEL

System	Indoor	Outdoor
FSNRP50B	FINRP50MB	HONRP50B

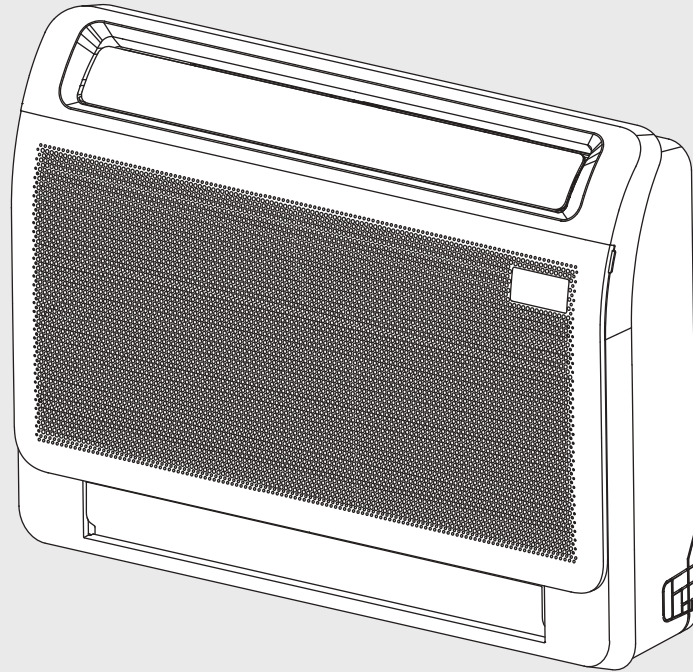

Single Split Floor Console Air Conditioner

Operation & Installation Manual

Rinnai



Read this Operation & Installation manual and **SAFETY MANUAL** carefully before installing or operating your air conditioning unit. Make sure you keep this manual in a safe place for future reference.

This appliance must be installed in accordance with:

- Manufacturer's Installation Instructions
- Current AS/NZS 3000, AS/NZS 5141, AS/NZS 5149
- Local Regulations and Municipal Building Codes including local OH&S requirements

This appliance must be installed, maintained and removed only by an Authorised Person.

For continued safety of this appliance it must be installed and maintained in accordance with the manufacturer's instructions.



TABLE OF CONTENTS

Warnings and Important Information	5
Safety Precautions	6
Minimum Room Size	7
Operation Range Limitations	7
Disposal Guidelines.....	9
Air Conditioner Basics	10
Indoor Unit Specifications and Features	10
Operating Temperature	11
Features	12
Adjusting Air Flow Direction	13
Care & Maintenance	14
Cleaning Your Indoor Unit	14
Cleaning Your Air Filter	14
Installation Record - Installer Details.....	16
Installation Record - System Details.....	16
Customer Care Program.....	16
Service Maintenance Schedule - Non Ducted Air Conditioning Systems.....	17
Troubleshooting	18
Remote Controller	20
Remote Specifications and Features	20
Operating Remote Controller	21
Button Functions	22
Remote Screen Indicators	23
Basic Functions	24
Setting TIMER	26
Advanced Functions	27
Accessories	31
Indoor Unit	32
Installation Summary	32
Description	33
Installation Instructions – Indoor Unit	34
Indoor Installation	34
Outdoor Installation	39
Installation Instructions – Outdoor Unit	39
Refrigerant Piping Connection	42
Connection Instructions – Refrigerant Piping	43

TABLE OF CONTENTS

Wiring	46
Outdoor Unit Wiring	47
Indoor Unit Wiring	48
Specifications	49
Power Specifications	49
Preparations and Precautions	50
Evacuation Instructions	50
Air Evacuation	50
Note on Adding Refrigerant	51
Test Run	52
Before Test Run	52
Electrical Safety Checks	52
Test Run Checks	52
Final Checklist.....	53
Warranty	54
Contacts	60

WARNINGS AND IMPORTANT INFORMATION



READ ALL INSTRUCTIONS BEFORE USING THE APPLIANCE.

Always comply with the following precautions to avoid dangerous situations and to ensure optimum performance.

Failure to carefully read and follow all instructions in this manual can result in equipment malfunction, property damage, personal injury and/or death.

DANGER: Indicates an imminently hazardous situation which, if not avoided, will result in personal injury or death.

WARNINGS: Indicates a potentially hazardous situation which, if not avoided, could result in personal injury or death.

CAUTIONS: Indicates a potentially hazardous situation which, if not avoided, could result in minor or moderate injury or damage to the appliance. It may also be used to alert against unsafe practices.



REGULATORY

This appliance shall be installed in accordance with:

Manufacturer's Installation Instructions.

Current AS/NZS 3000, AS/NZS 5141, AS/NZS 5149, AS/NZS 3500 National Plumbing & Drainage, HB276 - A Guide to good practice for energy efficient installation.

Local Regulations and Municipal Building Codes including local OH&S requirements.

This appliance must be installed, maintained and removed **ONLY** by an Authorised Person.

For continued safety of this appliance it must be installed and maintained in accordance with the manufacturers instructions.

This appliance uses R32 refrigerant.

This appliance is heavy, use 2 people or mechanical lifting device. Improper lifting may result in serious injury.

This appliance can be used by children aged from 8 years and above and persons with reduced physical, sensory or mental capabilities or lack of experience and knowledge if they have been given supervision or instruction concerning use of the appliance in a safe way and understand the hazards involved. Children shall not play with the appliance.

This appliance is not intended for use by persons (including children) with reduced physical, sensory or mental capabilities, or lack of experience and knowledge, unless they have been given supervision or instruction concerning use of the appliance by a person responsible for their safety. Children should be supervised to ensure that they do not play with the appliance.



MANDATORY INSPECTION PRIOR TO INSTALLATION

Immediately report any damage or discrepancies to the Supplier of the appliance. This appliance was inspected and tested at the time of manufacture and packaging, and released for transportation without known damage. Upon receipt, inspect the exterior for evidence of rough handling in shipment. Ensure that the appliance is labelled correctly for the gas and electrical supply, and/or other services it is intended to be connected to.

For safety and warranty purposes, appliances that may be damaged or incorrect **MUST NOT** be installed or operated under any circumstances. Installation of damaged or incorrect appliances may contravene local government regulations. Rinnai disclaims any liability or responsibility whatsoever in relation to the installation or operation of damaged or incorrect appliances.

Safety Precautions



PRODUCT INSTALLATION WARNINGS

This appliance shall be installed in accordance with local electrical safety regulations by an authorised person such as a licensed electrician. Contact an authorised service technician for repair or maintenance of this appliance.

Installation must be performed according to the installation instructions. Improper installation can cause water leakage, electrical shock, or fire.

Only use the included accessories, parts, and specified parts for installation. Using non-standard parts can cause water leakage, electrical shock, fire, and can cause the unit to fail.

Install the unit in a firm location that can support the unit's weight. If the chosen location cannot support the unit's weight, or the installation is not done properly, the unit may drop and cause serious injury and damage.

Install drainage piping according to the instructions in this manual. Improper drainage may cause water damage to your home and property.

For units that have an auxiliary electric heater, **DO NOT** install the unit within 1 meter (3 feet) of any combustible materials.

DO NOT install the unit in a location that may be exposed to combustible gas leaks. If combustible gas accumulates around the unit, it may cause fire.

DO NOT turn on the power until all work has been completed.

When moving or relocating the air conditioner, consult experienced service technicians for disconnection and reinstallation of the unit.

How to install the appliance to its support, please read the information for details in "indoor unit installation" and "outdoor unit installation" sections.

The unit must be earthed in accordance with local regulations.

Select an installation location where the components can be mounted securely and accessible for service and replacement.

Make sure to check for and rectify any refrigerant leaks after you install or repair the unit.

This appliance uses R32 (difluoromethane) refrigerant, which is a flammable gas class 2.2 according to AS/NZS 1677 and must be handled by a refrigeration mechanic with appropriate Australian refrigerant handling licence.



WARNINGS FOR PRODUCT USE

If an abnormal situation arises (like a burning smell), immediately turn off the unit and disconnect the power. Call your dealer for instructions to avoid electric shock, fire or injury.

DO NOT insert fingers, rods or other objects into the air inlet or outlet. This may cause injury, since the fan may be rotating at high speeds.

DO NOT use flammable sprays such as hair spray, lacquer or paint near the unit. This may cause fire or combustion.

DO NOT operate the air conditioner in places near or around combustible gases. Emitted gas may collect around the unit and cause explosion.

DO NOT operate your air conditioner in a wet room such as a bathroom or laundry room. Too much exposure to water can cause electrical components to short circuit.

DO NOT expose your body directly to cool air for a prolonged period of time.

DO NOT allow children to play with the air conditioner. Children must be supervised around the unit at all times.

If the air conditioner is used together with burners or other heating devices, thoroughly ventilate the room to avoid oxygen deficiency.

In certain functional environments, such as kitchens, server rooms, etc., the use of specially designed air-conditioning units is highly recommended.



USING R32 REFRIGERANT

When flammable refrigerant are employed, appliance shall be stored in a well-ventilated area where the room size corresponds to the room area as specified for operation.

Appliance shall be installed, operated and stored in a room with a floor area larger than X m². Appliance **MUST NOT** be installed in a unventilated space, if that space is smaller than X m². Refer to 'Minimum Room Size' table below.



REFRIGERANT

This appliance uses R32 (difluoromethane) refrigerant, which is a flammable gas class A2L according to AS 5149.1 and must be handled by a refrigeration mechanic with an appropriate Australian refrigerant handling licence.



WARNING Risk of fire / flammable material. If the refrigerant is leaked, together with an external ignition source, there is a possibility of ignition.



Read the OPERATING INSTRUCTIONS carefully before operation.



Service personnel are required to carefully read the OPERATING INSTRUCTIONS and INSTALLATION MANUAL before operation.



Further information is available in the OPERATING INSTRUCTIONS, INSTALLATION MANUAL, and the like.

Certain levels of refrigerant require minimum room sizes. Please ensure that these minimum room sizes are adhered to for standard installations. Please consult AS/NZS 60335.2.40 to determine the safe minimum floor area for the installation.

Make sure that the area has been made safe by having suitable ventilation and is free from ignition sources before charging or releasing the charge of R32.

Minimum Room Size

Model	FINRP50MB
Standard Charge (kW)	5.2
Minimum Room Area (m ²)	18.0

- All minimum room sizes in the above table are calculated on the base charge provided with the outdoor unit.
- Mechanical connectors used indoors shall comply with ISO 14903.
- This appliance shall be installed in accordance with AS/NZS 5149.
- When mechanical connectors are reused, sealing parts shall be renewed.
- When flared joints are reused, the flare part shall be re-fabricated.

Operation Range Limitations

The table below indicates the temperature ranges the air conditioner can be operated within.

MODE	Cool Mode	Heat Mode	Dry Mode
Room Temperature	> 16°C	< 30°C	> 16°C
Outdoor Temperature	0°C ~ 50°C	-15°C ~ 24°C	0°C ~ 50°C



CLEANING AND MAINTENANCE WARNINGS

Turn off the device and disconnect the power before cleaning. Failure to do so can cause electrical shock.

DO NOT clean the air conditioner with excessive amounts of water.

DO NOT clean the air conditioner with combustible cleaning agents. Combustible cleaning agents can cause fire or deformation.



OPERATING CAUTIONS

Turn off the air conditioner and disconnect the power if you are not going to use it for a long time. Turn off and unplug the unit during storms.

Make sure that water condensation can drain unhindered from the unit.

DO NOT operate the air conditioner with wet hands. This may cause electric shock.

DO NOT use device for any other purpose than its intended use.

DO NOT climb onto or place objects on top of the outdoor unit.

DO NOT allow the air conditioner to operate for long periods of time with doors or windows open, or if the humidity is very high.



ELECTRICAL WARNINGS

Only use the specified power cord. If the power cord is damaged, it must be replaced by the manufacturer, its service agent or similarly qualified persons in order to avoid a hazard.

Keep power plug clean. Remove any dust or grime that accumulates on or around the plug. Dirty plugs can cause fire or electric shock.

DO NOT pull power cord to unplug unit. Hold the plug firmly and pull it from the outlet. Pulling directly on the cord can damage it, which can lead to fire or electric shock.

DO NOT modify the length of the power supply cord or use an extension cord to power the unit.

DO NOT share the electrical outlet with other appliances. Improper or insufficient power supply can cause fire or electrical shock.

The product must be properly grounded at the time of installation, or electrical shock may occur.

For all electrical work, follow all local and national wiring standards, regulations, and the Installation Manual. Connect cables tightly, and clamp them securely to prevent external forces from damaging the terminal. Improper electrical connections can overheat and cause fire, and may also cause shock. All electrical connections must be made according to the Electrical Connection Diagram located on the panels of the indoor and outdoor units.

All wiring must be properly arranged to ensure that the control board cover can close properly. If the control board cover is not closed properly, it can lead to corrosion and cause the connection points on the terminal to heat up, catch fire, or cause electrical shock.

If connecting power to fixed wiring, an all-pole disconnection device which has at least 3mm clearances in all poles, and have a leakage current that may exceed 10mA, the residual current device (RCD) having a rated residual operating current not exceeding 30mA, and disconnection must be incorporated in the fixed wiring in accordance with the wiring rules.



A NOTE ON ILLUSTRATIONS

The illustrations used in this manual are for explanatory purposes only and the shape of your indoor unit may vary slightly from that which is shown in this manual.



FUSE SPECIFICATIONS

The air conditioner’s circuit board (PCB) is designed with a fuse to provide overcurrent protection. The specifications of the fuse are printed on the circuit board ,such as:
 T3.15AL/250VAC, T5AL/250VAC, T3.15A/250VAC, T5A/250VAC, T20A/250VAC, T30A/250VAC,etc.
NOTE: For the units using R32 refrigerant, only the blast-proof ceramic fuse can be used.



FLUORINATED GASES

This air-conditioning unit contains fluorinated greenhouse gases. For specific information on the type of gas and the amount, please refer to the relevant label on the appliance itself or the “Operation Manual” in the packaging of the outdoor unit.
 Installation, service, maintenance and repair of this unit must be performed by a certified technician.
 Product uninstallation and recycling must be performed by a certified technician.
 For equipment that contains fluorinated greenhouse gases in quantities of 5 tonnes of CO₂ equivalent or more, but of less than 50 tonnes of CO₂ equivalent, If the system has a leak detection system installed, it must be checked for leaks at least every 24 months.
 When the unit is checked for leaks, proper record-keeping of all checks is strongly recommended.

DISPOSAL GUIDELINES

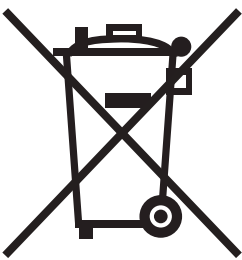

This appliance contains refrigerant and other potentially hazardous materials. When disposing of this appliance, the law requires special collection and treatment. **DO NOT** dispose of this product as household waste or unsorted municipal waste.



Special notice – Disposing of this appliance in the forest or other natural surroundings endangers your health and is bad for the environment. Hazardous substances may leak into the ground water and enter the food chain.

AIR CONDITIONER BASICS

Indoor Unit Specifications and Features

NOTE: This display panel on the indoor unit can be used to operate the unit in case the remote control has been misplaced or is out of batteries.

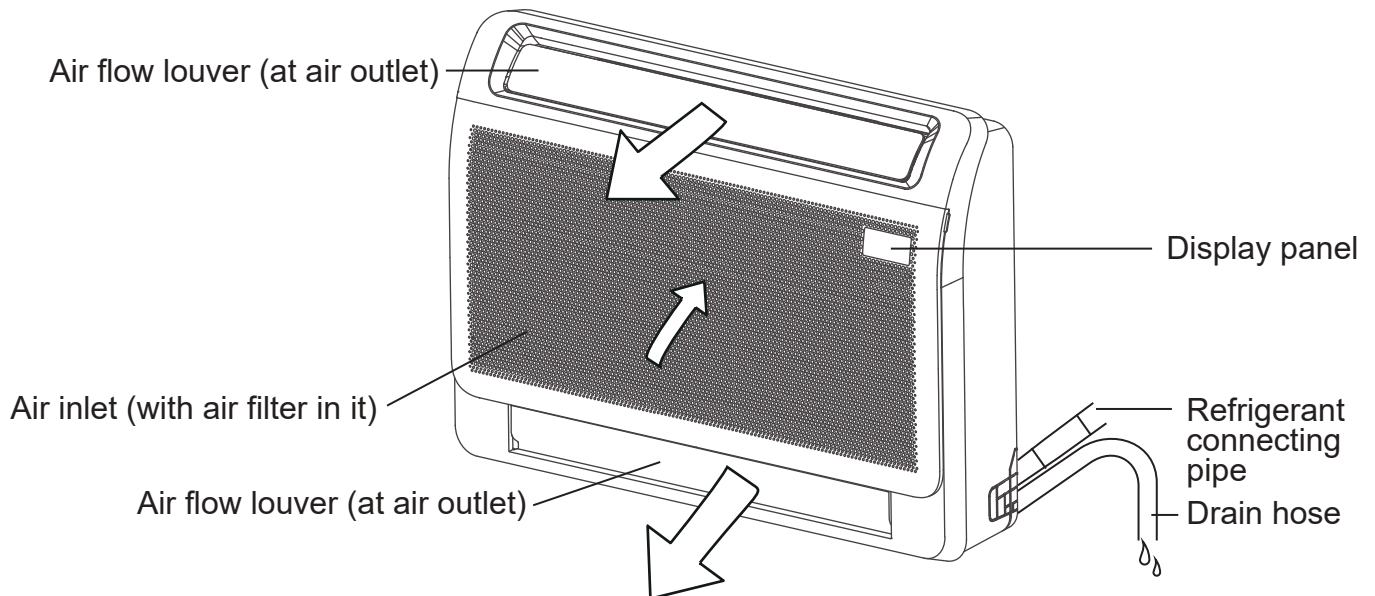

Display panel

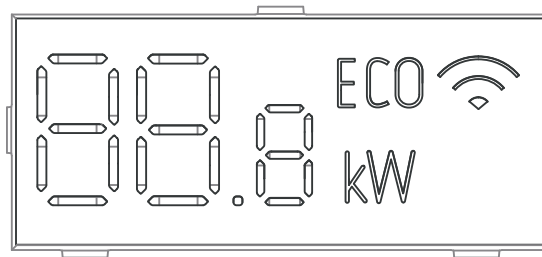

- **88.8** Displays temperature and Error codes:
 - "dF" when defrosting (for model B cooling & heating units)
 - "01" for 3 seconds when:
 - TIMER ON is set
 - SWING or SILENCE is turned on
 - "0F" for 3 seconds when:
 - TIMER OFF is set
 - SWING or SILENCE is turned off
 - "CL" when unit is self-cleaning
 - "FP" when 8°C heating feature is turned on
- **ECO** When ECO function (some units) is activated.
-  when Wireless Control feature is activated (some units)

Operating Temperature

When your air conditioner is used outside of the following temperature ranges, certain safety protection features may activate and cause the unit to disable.

Inverter Split Type

	COOL mode	HEAT mode	DRY mode
Room Temperature	16°C - 32°C	0°C - 30°C	10°C - 32°C
Outdoor Temperature	0°C - 50°C	-15°C - 24°C	0°C - 50°C
	-15°C - 50°C (For models with low temp. cooling systems.)		
	0°C - 52°C (For special tropical models)		0°C - 52°C (For special tropical models)

FOR OUTDOOR UNITS WITH AUXILIARY ELECTRIC HEATER
When outside temperature is below 0°C, we strongly recommend keeping the unit plugged in at all time to ensure smooth ongoing performance.

Fixed-speed Type

	COOL mode	HEAT mode	DRY mode
Room Temperature	16°C-32°C	0°C-30°C	10°C-32°C
Outdoor Temperature	18°C-43°C	-7°C-24°C	11°C-43°C
	-7°C-43° (For models with low-temp cooling systems)		18°C-43°C
	18°C-52°C (For special tropical models)		18°C-52°C (For special tropical models)

NOTE: Room relative humidity less than 80%. If the air conditioner operates in excess of this figure, the surface of the air conditioner may attract condensation. Please sets the vertical air flow louver to its maximum angle (vertically to the floor), and set HIGH fan mode.

To further optimise the performance of your unit, do the following:

- Keep doors and windows closed.
- Limit energy usage by using TIMER ON and TIMER OFF functions.
- Do not block air inlets or outlets.
- Regularly inspect and clean air filters.

Features

Default Setting (some models)

When the air conditioner restarts after a power failure, it will default to the factory settings (AUTO mode, AUTO fan, 24°C). This may cause inconsistencies on the remote control and unit panel. Use your remote control to update the status.

Auto-Restart (some models)

In case of power failure, the system will immediately stop. When power returns, the Operation light on the indoor unit will flash. To restart the unit, press the ON/OFF button on the remote control. If the system has an auto restart function, the unit will restart using the same settings.

When the outdoor temperature is below zero, the electric heating belt of the outdoor unit chassis is used for ice melting, without defrosting (some models).

Louver Angle Memory Function (some models)

Some models are designed with a louver angle memory function. When the unit restarts after a power failure, the angle of the horizontal louvers will automatically return to the previous position. The angle of the horizontal louver should not be set too small as condensation may form and drip into the machine. To reset the louver, press the manual button, which will reset the horizontal louver settings.

Refrigerant Leak Detection System (some models)

The indoor unit will automatically display "EC" or "EL0C" or flash LEDs (model dependent) when it detects refrigerant leakage.

Adjusting Air Flow Direction

- **Manual Swing:** Press Air Direction to fix the louver at a desired angle. The louver swings (upward or downward) at a different angle with each press of the button. The air direction can be changed by manually adjusting air louver.

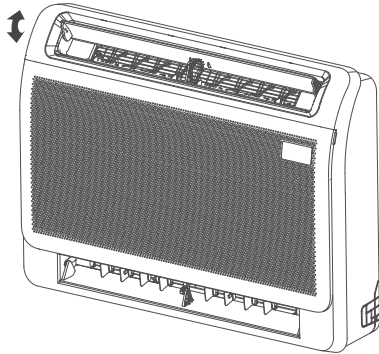

- **When cooling**
Adjust the louver downwards (horizontally).

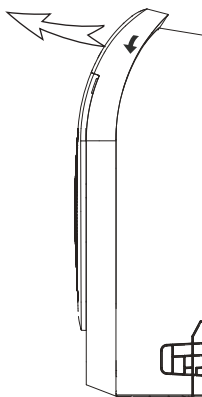

- **When heating**
Adjust the louver vertically.

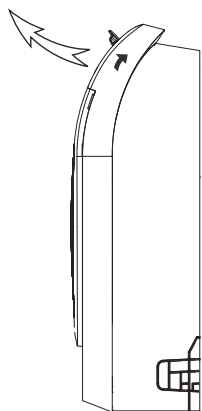

- **Lower air louver switch setting**
Under the condition of meeting the ambient temperature, the lower air louver can be opened when the unit is turned on. To select whether the lower air louver is on or off, use the button on the electric control box. Within 10 minutes of power-on, press  it for 5 seconds to enter the mode in standby state. Press it to open or close the lower air louver.

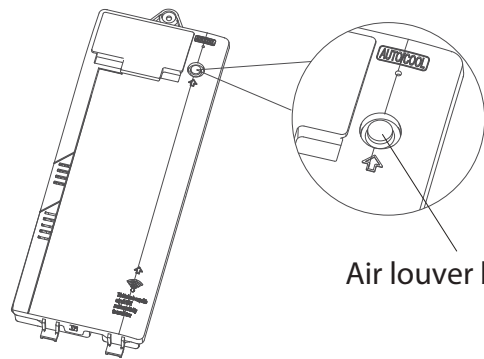

Air louver button

Electric control box

NOTE: During the setting process, the display panel displays the switch status of the lower air louver.
on - open
of - closed

CAUTION

Do not try to adjust the horizontal louver by hand. This may cause damage the mechanism and result in condensation forming on the air outlets.

CARE & MAINTENANCE

Cleaning Your Indoor Unit



BEFORE CLEANING OR MAINTENANCE

ALWAYS TURN OFF YOUR AIR CONDITIONER SYSTEM AND DISCONNECT ITS POWER SUPPLY BEFORE CLEANING OR MAINTENANCE.



CAUTION

Only use a soft, dry cloth to wipe the unit clean. If the unit is especially dirty, you can use a cloth soaked in warm water to wipe it clean.

- Do not use chemicals or chemically treated cloths to clean the unit
- Do not use benzene, paint thinner, polishing powder or other solvents to clean the unit. They can cause the plastic surface to crack or deform.
- Do not use water hotter than 40°C to clean the front panel. This can cause the panel to deform or become discolored.

Cleaning Your Air Filter

A clogged air conditioner can reduce the cooling efficiency of your unit, and can also be bad for your health. Make sure to clean the filter once every two weeks.



WARNING: DO NOT REMOVE OR CLEAN THE FILTER BY YOURSELF

Removing and cleaning the filter can be dangerous. Removal and maintenance must be performed by a certified technician.

1. Pull the left and right handles of the front panel, pull the panel outward, and open the panel.
2. Remove the air filter.
Press the claws on the right and left sides of the air filter down slightly, then pull upward.
3. Hold the tabs of the frame, and remove the 4 claws. (The special function filter can be washed with water once every 6 months. It is recommended that you replace it once every 3 years.)

4. Clean the air filter by vacuuming the surface or washing it in warm water with mild detergent.
5. Rinse the filter with clean water and allow it to air-dry. **DO NOT** let the filter dry in direct sunlight.
6. Reinstall the filter.

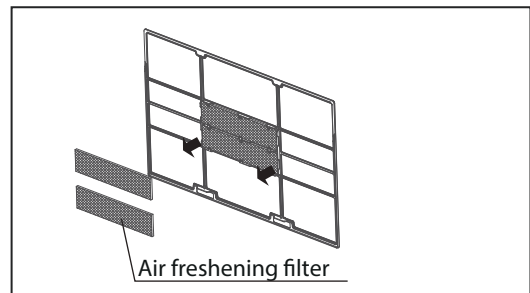
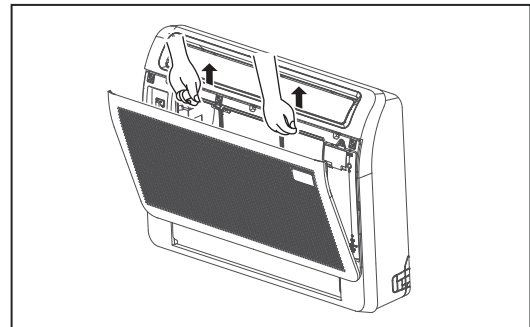
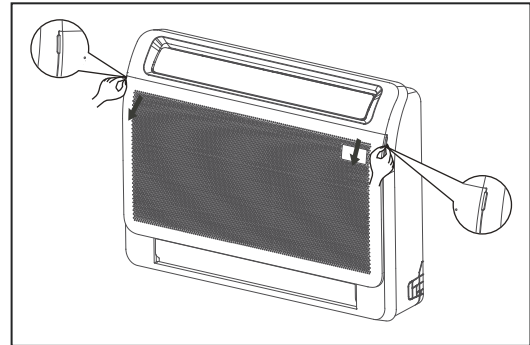

If using water, the inlet side should face down and away from the water stream.

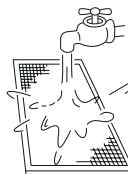

If using a vacuum cleaner, the inlet side should face the vacuum.

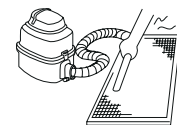

⚠ CAUTION

- Before changing the filter or cleaning, turn off the unit and disconnect its power supply.
- When removing filter, do not touch metal parts in the unit. The sharp metal edges can cut you.
- Do not use water to clean the inside of the indoor unit. This can destroy insulation and cause electrical shock.
- Do not expose filter to direct sunlight when drying. This can shrink the filter.
- Any maintenance and cleaning of outdoor unit should be performed by an authorised dealer or a licensed service provider.
- Any unit repairs should be performed by an authorised dealer or a licensed service provider.

Replace internal parts

1. Pull the left and right handles of the front panel, pull the panel outward, and open the panel.
2. Remove the 7 screws on the face frame.

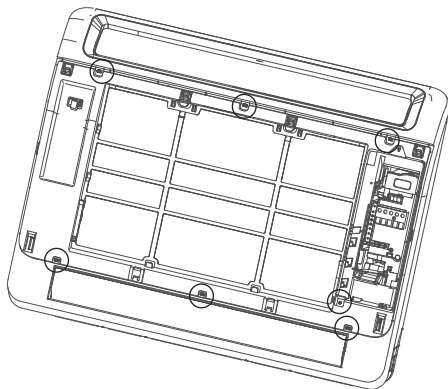

3. Buckle up the snap indicated by the arrow and remove the face frame.

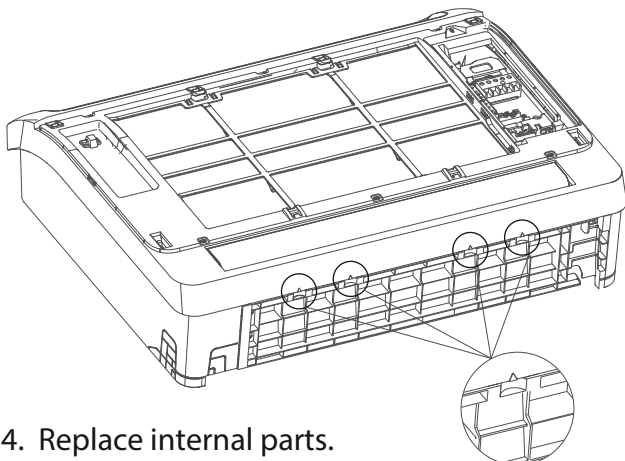

4. Replace internal parts.
5. Install the face frame and panel parts.

Maintenance – Long Periods of Non-Use

If you plan not to use your air conditioner for an extended period of time, do the following:

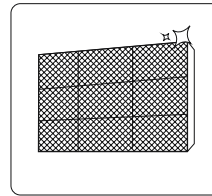

Clean all filters

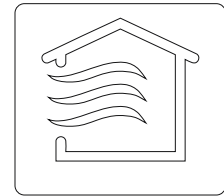

Turn on FAN function until unit dries out completely

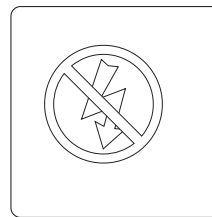

Turn off the unit and disconnect the power

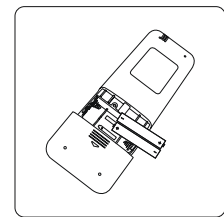

Remove batteries from remote control

Maintenance – Pre-Season Inspection

After long periods of non-use, or before periods of frequent use, do the following:

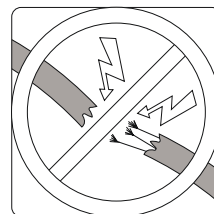

Check for damaged wires

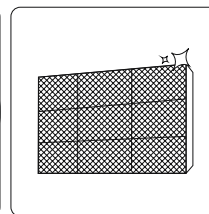

Clean all filters



Check for leaks

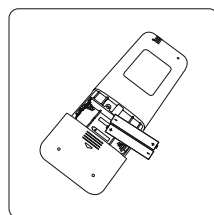

Replace batteries



Make sure nothing is blocking all air inlets and outlets

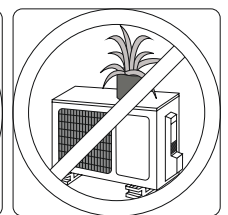

NOTE: Do not stretch or hang objects at the air outlet.
Do not adjust the automatic air deflector by hand or extend your hand into the air duct.
Do not cover the air inlet and outlet of the unit with objects.

INSTALLATION RECORD - INSTALLER DETAILS

Company Name: _____

Company Address: _____

Telephone: _____

Mobile Phone: _____

Email: _____

Certificate of Compliance / Certification No. _____

Authorised Persons - Licence No. _____

Installers Name: _____

Installers Signature: _____

Installation Date: _____

INSTALLATION RECORD - SYSTEM DETAILS

Model Number : _____

Serial Number Indoor Unit: _____

Serial Number Outdoor Unit: _____

Installation Address: _____

CUSTOMER CARE PROGRAM

Please ensure you register your product warranty on line at rinnai.com.au.

The Rinnai Customer Care Program is designed to help you get the most out of your new system.

Service and maintenance in accordance with the Service Maintenance Schedule on page 17 are essential in ensuring the prolonged useful life of your system, and help ensure it operates at optimum efficiency. We may contact you before each winter or summer season with preferential offers for preventative maintenance services which will keep your Rinnai system in great condition.



Service maintenance is not covered under warranty and is a chargeable service. All units **MUST have safe and reasonable access and be installed in compliance with the installation instructions supplied with the unit. Some installations may require two service personnel to attend, in accordance with Health and Safety requirements.**

Also note that all refrigerated air conditioning systems have air filters that require regular inspection and cleaning. Please refer to "Cleaning Your Air Filter" on page 14.

SERVICE MAINTENANCE SCHEDULE - NON DUCTED AIR CONDITIONING SYSTEMS

Your Rinnai Air Conditioning System should be maintained annually after the date of installation by a qualified licensed technician in accordance with the Schedule below. Failure to do so during the product warranty period may void your warranty. This periodic service and maintenance will prolong the useful life of the unit, and help keep it running safely and at optimum efficiency.

Date of Installation	/ /		Installed By:			
Service Year	1	2	3	4	5	6
Service Date	/ /	/ /	/ /	/ /	/ /	/ /
Service Company / Technician						
Ambient Temperature at CDU (°C)						
ELECTRICAL						
Wiring, Electrical connections						
Fan Motors						
Capacitors (if applic)						
Printed circuit boards						
MAJOR COMPONENTS						
Outdoor unit clearances						
Outdoor unit condensate tray						
Outdoor unit condensate drain						
Outdoor unit fixing						
Indoor unit condensate tray						
Indoor unit condensate drain / pump						
Refrigerant charge						
Refrigeration connections						
Fan assemblies						
Return Air grille & filters						
CONTROLS						
Louver operation						
Remote operation						
System Operation						
Sequence of operation						
Return Air Temp - Cooling/ Heating	°C	°C	°C	°C	°C	°C
Outlet Air Temp - Cooling / Heating	°C	°C	°C	°C	°C	°C
Outdoor unit - Liquid line pressure	kPa	kPa	kPa	kPa	kPa	kPa
Outdoor unit - Suction line pressure	kPa	kPa	kPa	kPa	kPa	kPa
GENERAL INSTALLATION-RELATED AND 3rd PARTY COMPONENTS (NOT RINNAI PRODUCTS) *						
Airflow through system						
Refrigerant pipework						
Safety tray						
Wall mounting						
CONSUMABLES **						
Capacitors						
Filters						
Batteries (If applic)						
* Installation and other field-supplied components are not covered by Rinnai Product Warranty. These include, but are not limited to, control wiring, refrigerant gas and electrical connections to the appliance. These should be inspected as they can affect the performance, reliability and safety of the system.						
** Units contain consumable items that may require periodic replacement and are not covered by Rinnai product warranty (e.g. filters, capacitors and batteries)						
ACTION CODES						
Inspected - Working Correctly - No Action Required	Adjusted Part	Cleaned Part	Replaced Part	Repaired Part	Referred to Installer	
✓	A	C	R	RP	RI	

TROUBLESHOOTING



SAFETY PRECAUTIONS

If any of the following conditions occurs, turn off your unit immediately!

- The power cord is damaged or abnormally warm
- You smell a burning odor
- The unit emits loud or abnormal sounds
- A power fuse blows or the circuit breaker frequently trips
- Water or other objects fall into or out of the unit

DO NOT ATTEMPT TO FIX THESE YOURSELF! CONTACT AN AUTHORISED SERVICE PROVIDER IMMEDIATELY!

Common Issues

The following problems are not a malfunction and in most situations will not require repairs.

Issue	Possible Causes
Unit does not turn on when pressing ON/OFF button	The Unit has a 3-minute protection feature that prevents the unit from overloading. The unit cannot be restarted within three minutes of being turned off.
	Cooling and Heating Models: If the Operation light and PRE-DEF (Pre-heating/Defrost) indicators are lit up, or the Operation light is lit up and the LCD screen display "dF", the outdoor temperature is too cold and the unit's anti-cold wind is activated in order to defrost the unit.
The unit changes from COOL mode to FAN mode	The unit may change its setting to prevent frost from forming on the unit. Once the temperature increases, the unit will start operating in the previously selected mode again.
	The set temperature has been reached, at which point the unit turns off the compressor. The unit will continue operating when the temperature fluctuates again.
The indoor unit emits white mist	In humid regions, a large temperature difference between the room's air and the conditioned air can cause white mist.
Both the indoor and outdoor units emit white mist	When the unit restarts in HEAT mode after defrosting, white mist may be emitted due to moisture generated from the defrosting process.
The indoor unit makes noises	A squeaking sound is heard when the system is OFF or in COOL mode. The noise is also heard when the drain pump (optional) is in operation.
	A squeaking sound may occur after running the unit in HEAT mode due to expansion and contraction of the unit's plastic parts.
Both the indoor unit and outdoor unit make noises	Low hissing sound during operation: This is normal and is caused by refrigerant gas flowing through both indoor and outdoor units.
	Low hissing sound when the system starts, has just stopped running, or is defrosting: This noise is normal and is caused by the refrigerant gas stopping or changing direction.
	Squeaking sound: Normal expansion and contraction of plastic and metal parts caused by temperature changes during operation can cause squeaking noises.

Issue	Possible Causes
The outdoor unit makes noises	The unit will make different sounds based on its current operating mode.
Dust is emitted from either the indoor or outdoor unit	The unit may accumulate dust during extended periods of non-use, which will be emitted when the unit is turned on. This can be mitigated by covering the unit during long periods of inactivity.
The unit emits a bad odor	The unit may absorb odors from the environment (such as furniture, cooking, cigarettes, etc.) which will be emitted during operations.
	The unit's filters have become moldy and should be cleaned.
The fan of the outdoor unit does not operate	During operation, the fan speed is controlled to optimize product operation.

NOTE: If problem persists, contact a local dealer or your nearest customer service center. Provide them with a detailed description of the unit malfunction as well as your model number.

Troubleshooting

When troubles occur, please check the following points before contacting a repair company.

Problem	Possible Causes	Solution
Poor Cooling Performance	Temperature setting may be higher than ambient room temperature	Lower the temperature setting
	The heat exchanger on the indoor or outdoor unit is dirty	Clean the affected heat exchanger
	The air filter is dirty	Remove the filter and clean it according to instructions
	The air inlet or outlet of either unit is blocked	Turn the unit off, remove the obstruction and turn it back on
	Doors and windows are open	Make sure that all doors and windows are closed while operating the unit
	Excessive heat is generated by sunlight	Close windows and curtains during periods of high heat or bright sunshine
	Too many sources of heat in the room (people, computers, electronics, etc.)	Reduce amount of heat sources
	Low refrigerant due to leak or long-term use	Check for leaks, re-seal if necessary and top off refrigerant

REMOTE CONTROLLER

Remote Specifications and Features

Model	RG10L3(2HS)/BGEF
Rated Voltage	3.0V(Dry batteries R03/LR03×2)
Signal Receiving Range	Maximum 8m (vertical distance)
Environment	-5°C~60°C

Quick Start Guide

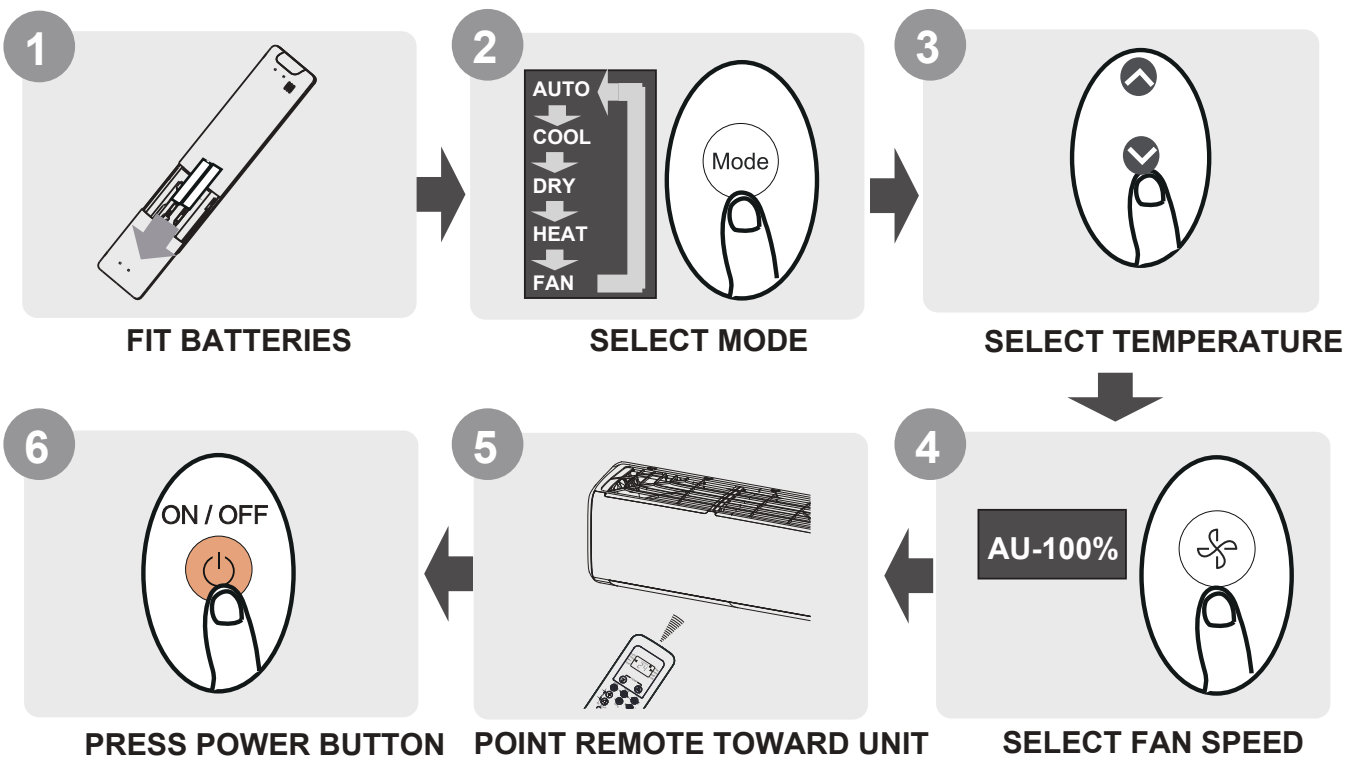

NOT SURE WHAT A FUNCTION DOES?

Refer to the **How to Use Basic Functions** and **How to Use Advanced Functions** sections of this manual for a detailed description of how to use your air conditioner.

SPECIAL NOTE

- Button designs on your unit may differ slightly from the example shown.
- If the indoor unit does not have a particular function, pressing that function's button on the remote control will have no effect.
- When there are wide differences between "Remote Controller Manual" and "OPERATION MANUAL" on function description, the description of "OPERATION MANUAL" shall prevail.

Operating Remote Controller

Inserting and Replacing Batteries

Your air conditioning unit may come with two batteries (some units). Put the batteries in the remote control before use.

1. Slide the back cover from the remote control downward, exposing the battery compartment.
2. Insert the batteries, paying attention to match up the (+) and (-) ends of the batteries with the symbols inside the battery compartment.
3. Slide the battery cover back into place.

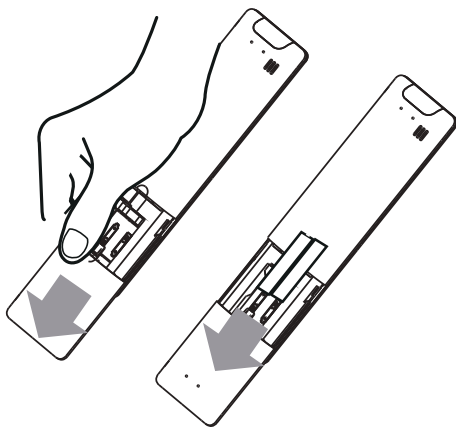

Remote Control

- Direct sunlight can interfere with the infrared signal receiver.
- There must be a clear line of sight between the remote and the appliance.
- If the signals from the remote control happen to control another appliance, move the appliance to another location or contact customer service.

! Battery Disposal

- Do not dispose of batteries as unsorted municipal waste. Refer to local laws for proper disposal of batteries.
- Batteries may have a chemical symbol at the bottom of the disposal icon. This chemical symbol means that the battery contains a heavy metal that exceeds a certain concentration. An example is Pb: Lead (>0.004%).
- Appliances and used batteries must be treated in a specialised facility for reuse, recycling and recovery. By ensuring correct disposal, you will help avoid possible negative consequences for the environment and human health.



Battery Performance

For optimal product performance:

- Do not mix old and new batteries, or batteries of different brands.
- Do not leave batteries in the remote control if you don't plan on using the device for more than 2 months.

Notes For Using Remote Control

The device could comply with the local national regulations.

- (1) This device may not cause harmful interference, and
- (2) this device must accept any interference received, including interference that may cause undesired operation.

This equipment has been tested and found to comply with the limits for a Class B digital device, pursuant to part 15 of the FCC Rules. These limits are designed to provide reasonable protection against harmful interference in a residential installation. This equipment generates, uses and can radiate radio frequency energy and, if not installed and used in accordance with the instructions, may cause harmful interference to radio communications. However, there is no guarantee that interference will not occur in a particular installation. If this equipment does cause harmful interference to radio or television reception, which can be determined by turning the equipment off and on, the user is encouraged to try to correct the interference by one or more of the following measures:

- Reorient or relocate the receiving antenna.
- Increase the separation between the equipment and receiver.
- Connect the equipment into an outlet on a circuit different from that to which the receiver is connected.
- Consult the dealer or an experienced radio/TV technician for help.
- Changes or modifications not approved by the party responsible for compliance could void user's authority to operate the equipment.

Button Functions

Before you begin using your new air conditioner, make sure to familiarise yourself with its remote control. The following is a brief introduction to the remote control itself. For instructions on how to operate your air conditioner, refer to the **How to Use Basic Functions** section of this manual.

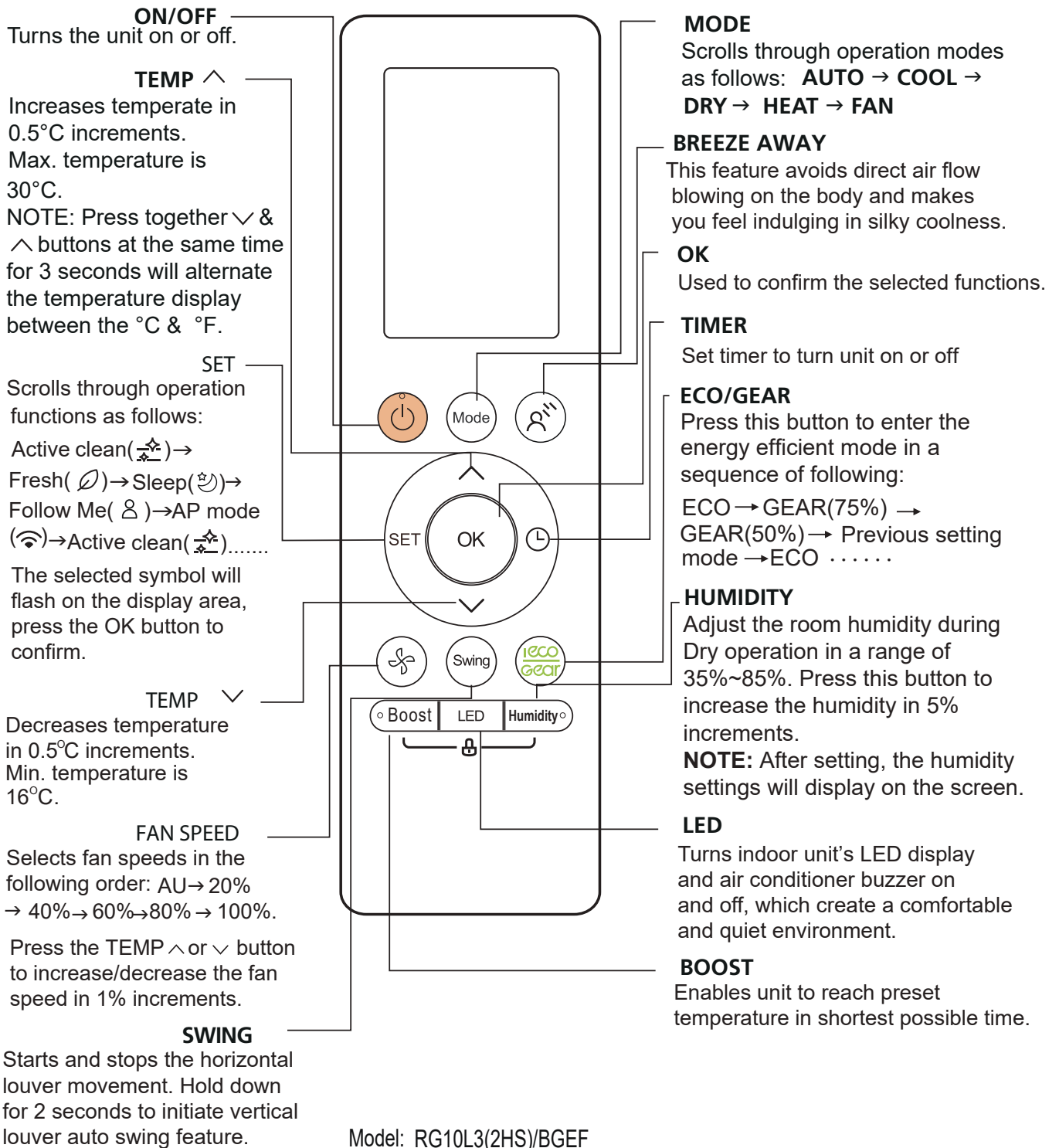

Remote Screen Indicators

Information are displayed when the remote controller is power up.

- | | | | |
|--|------------------------------|--|---|
| | Not applicable for this unit | | Active clean feature display |
| | Breeze Away display | | Fresh feature display |
| | Not applicable for this unit | | Sleep mode display |
| | Not applicable for this unit | | Follow me feature display |
| | Not applicable for this unit | | Wireless control feature display |
| | Not applicable for this unit | | Low battery detection display(If flashes) |

Transmission Indicator
Lights up when remote sends signal to indoor unit

- TIMER ON display**
- TIMER OFF display**

Silence feature display

FAN SPEED display
Displays selected fan speed:

Silence		1%
LOW		2%-20%
MED		21%-40%
HIGH		41%-60%
		61%-80%
AUTO		81%-100%

This fan speed can not be adjusted in AUTO or DRY mode.

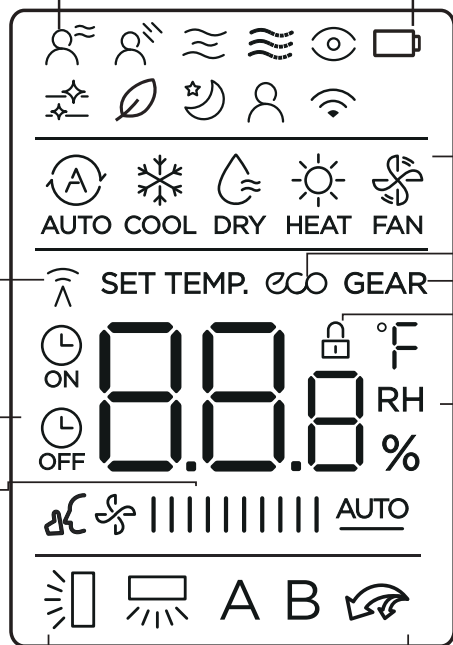

MODE display
Displays the current mode, including:

AUTO COOL DRY HEAT FAN

ECO display
Displays when ECO feature is activated

GEAR display
Displays when GEAR feature is activated

LOCK display
Displays when LOCK feature is activated.

Temperature/Timer/Fan speed display
Displays the set temperature by default, or fan speed or timer setting when using TIMER ON/OFF functions.

- Temperature range: 16-30°C, 20-28°C (Model dependent)
- Timer setting range: 0-24 hours
- Fan speed setting range: AU -100%
- Humidity setting range: 35% -85%

This display is blank when operating in FAN mode.

Horizontal louver swing display

TURBO mode display
A Not applicable for this unit
B Not applicable for this unit

Note:

All indicators shown in the figure are for the purpose of clear presentation. But during the actual operation, only the relative function signs are shown on the display window.

Basic Functions

Basic operation

ATTENTION! Before operation, please ensure the unit is plugged in and power is available.

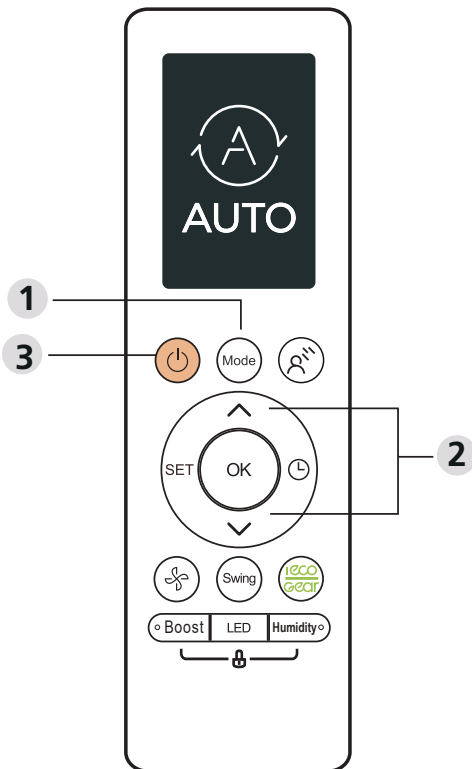

COOL Mode

1. Press the **MODE** button to select **COOL** mode.
2. Set your desired temperature using the **TEMP** \wedge or **TEMP** \vee button.
3. Press **FAN** button to select the fan speed in a range of AU-100%.
4. Press the **ON/OFF** button to start the unit.

SETTING TEMPERATURE

The operating temperature range for units is 16-30°C /20-28°C (Model dependent). You can increase or decrease the set temperature in 0.5°C increments.

AUTO Mode

In AUTO mode, the unit will automatically select the COOL, FAN, or HEAT operation based on the set temperature.

1. Press the **MODE** button to select **AUTO**.
2. Set your desired temperature using the **TEMP** \wedge or **TEMP** \vee button.
3. Press the **ON/OFF** button to start the unit.

NOTE: FAN SPEED can't be set in AUTO mode.

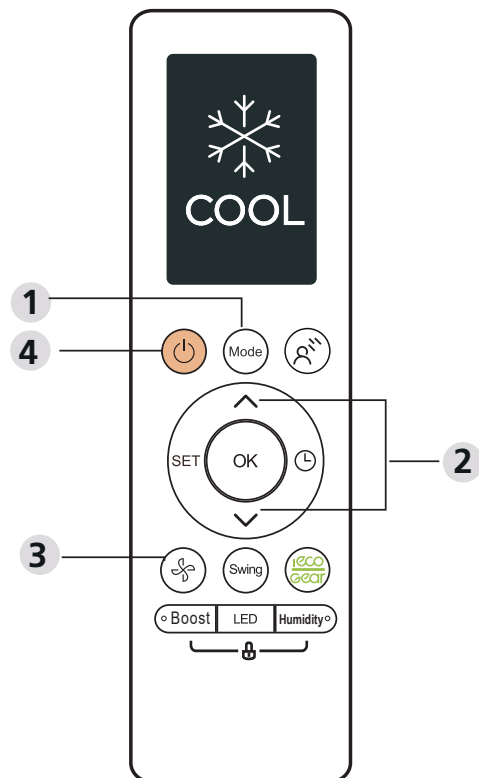

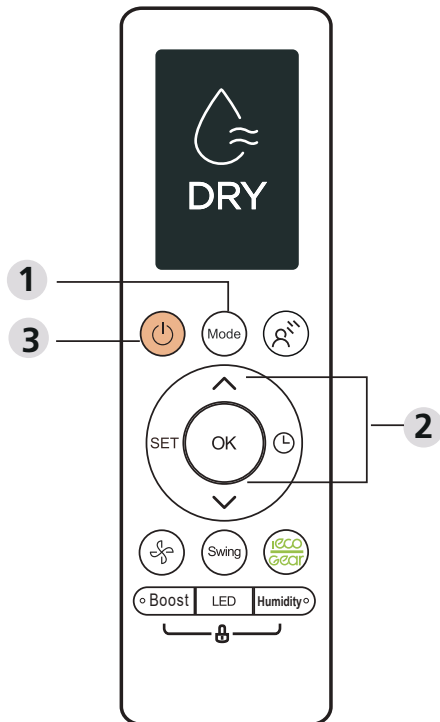

DRY Mode (dehumidifying)

1. Press the **MODE** button to select **DRY**.
2. Set your desired temperature using the **TEMP ^** or **TEMP v** button.
3. Press the **ON/OFF** button to start the unit.

NOTE: FAN SPEED cannot be changed in DRY mode.

FAN Mode

1. Press the **MODE** button to select **FAN** mode.
2. Press **FAN** button to select the fan speed in a range of AU-100%.
3. Press the **ON/OFF** button to start the unit.

NOTE: You can't set temperature in FAN mode. As a result, your remote control's LCD screen will not display temperature.

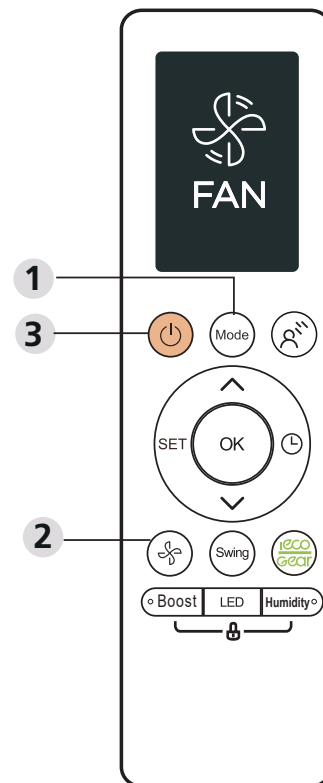

HEAT Mode

1. Press the **MODE** button to select **HEAT** mode.
2. Set your desired temperature using the **TEMP ^** or **TEMP v** button.
3. Press **FAN** button to select the fan speed in a range of AU-100%.
4. Press the **ON/OFF** button to start the unit.

NOTE: As outdoor temperature drops, the performance of your unit's HEAT function may be affected. In such instances, we recommend using this air conditioner in conjunction with other heating appliances.

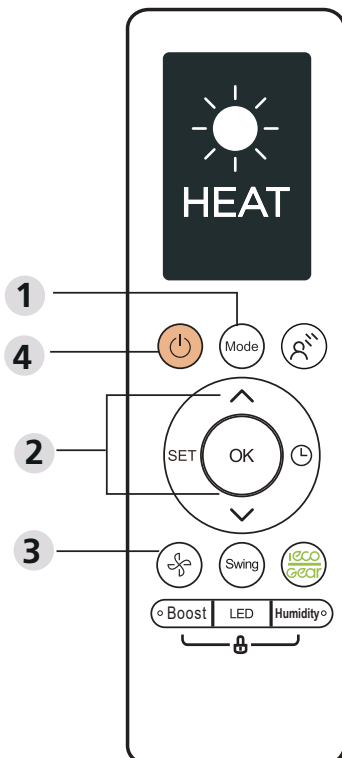

Setting TIMER

TIMER ON/OFF - Set the amount of time after which the unit will automatically turn on/off.

TIMER ON setting

Press TIMER button to initiate the ON time sequence.

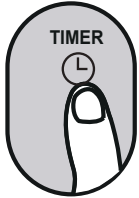

Press Temp. up or down button for multiple times to set the desired time to turn on the unit.

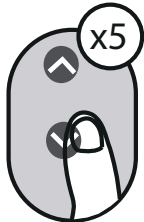

Point remote to unit and wait 1sec, the TIMER ON will be activated.



TIMER OFF setting

Press TIMER button to initiate the OFF time sequence.

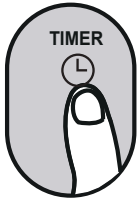

Press Temp. up or down button for multiple times to set the desired time to turn off the unit.



Point remote to unit and wait 1sec, the TIMER OFF will be activated.



NOTE:

- When setting the TIMER ON or TIMER OFF, the time will increase by 30 minutes increments with each press, up to 10 hours. After 10 hours and up to 24, it will increase in 1 hour increments. (For example, press 5 times to get 2.5h, and press 10 times to get 5h,) The timer will revert to 0.0 after 24.
- Cancel either function by setting its timer to 0.0h.

TIMER ON & OFF setting(example)

Keep in mind that the time periods you set for both functions refer to hours after the current time.

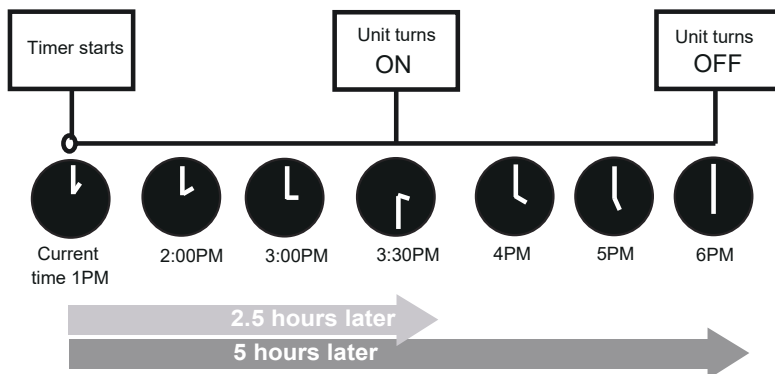
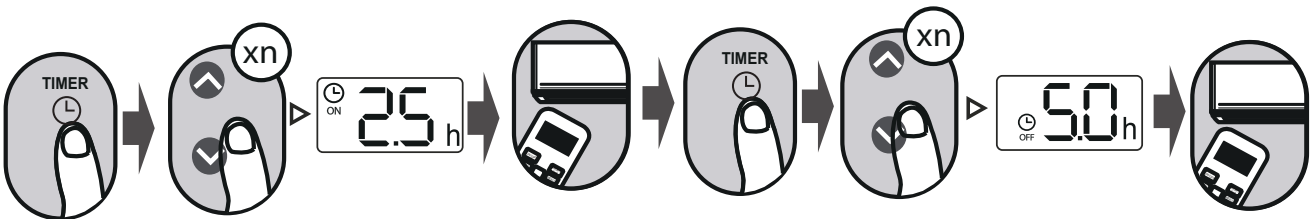

Example: If current timer is 1:00PM, to set the timer as above steps, the unit will turn on 2.5h later (3:30PM) and turn off at 6:00PM.

Advanced Functions

Swing function

Press Swing button

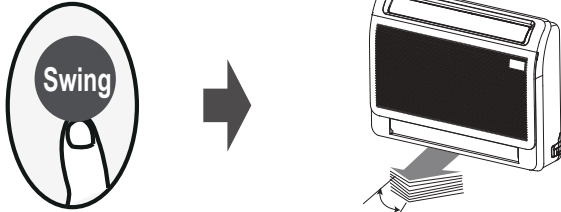

The horizontal louver will swing up and down automatically when pressing Swing button. Press again to make it stop.

Airflow direction

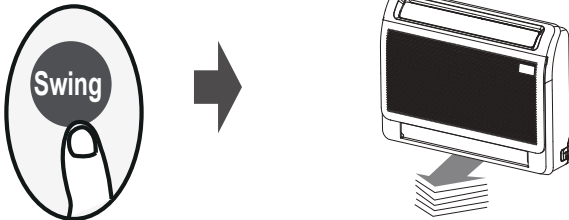

NOTE: When the unit is off, press and hold **MODE** and **SWING** buttons together for one second, the louver will open for a certain angle, which makes it very convenient for cleaning. Press and hold **MODE** and **SWING** buttons together for one second to reset the louver(some units only).

LED DISPLAY

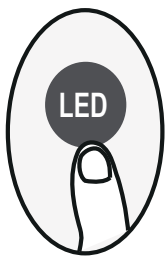

Press LED button

Press this button to turn on and turn off the display on the indoor unit.

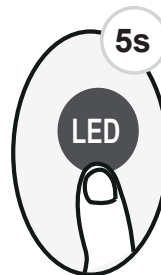

Press this button more than 5 seconds(some units)

Keep pressing this button more than 5 seconds, the indoor unit will display the actual room temperature. Press more than 5 seconds again will revert back to display the setting temperature.

ECO/GEAR function



Press X-ECO button to enter the energy efficient mode in a sequence of following:
 ECO → GEAR(75%) → GEAR(50%) → Previous setting mode → ECO.....

Note: This function is only available under COOL mode.

ECO operation:

Under cooling mode, press this button, the remote controller will adjust the temperature automatically to 24°C, fan speed of Auto to save energy (only when the set temperature is less than 24°C). If the set temperature is above 24°C, press the ECO button, the fan speed will change to Auto, the set temperature will remain unchanged.

NOTE:

Pressing the ECO button, or modifying the mode or adjusting the set temperature to less than 24°C will stop ECO operation.

Under ECO operation, the set temperature should be 24°C or above, it may result in insufficient cooling. If you feel uncomfortable, just press the ECO button again to stop it.

GEAR operation:

Press the ECO/GEAR button to enter the GEAR operation as following:
 75%(up to 75% electrical energy consumption)



50%(up to 50% electrical energy consumption)



Previous setting mode.

Under GEAR operation, the display on the remote controller will alternate between electrical energy consumption and set temperature.

BREEZE AWAY

Press this button



This feature avoids direct air flow blowing on the body and makes you feel indulging in silky coolness.

NOTE:

This feature is available under cool, Fan and Dry mode only.

Silence function



Keep pressing Fan button for more than 2 seconds to activate/disable Silence function (some units).

Due to low frequency operation of compressor, it may result in insufficient cooling and heating capacity. Press ON/OFF, Mode, Sleep, Turbo or Clean button while operating will cancel silence function.

FP function

Press this button 2 times during one second under HEAT Mode and setting temperature of 16°C or 20°C (for model RG10L10(2HS)/BGEF only).

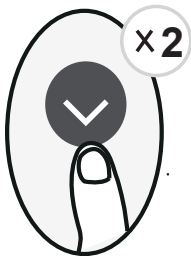

The unit will operate at high fan speed (while compressor on) with temperature automatically set to 8°C.

Note: This function is for heat pump air conditioner only.

Press this button 2 times during one second under HEAT Mode and setting temperature of 16°C or 20°C (for model RG10L10(2HS)/BGEF) to activate FP function. Press On/Off, Sleep, Mode, Fan and Temp. button while operating will cancel this function.

LOCK function

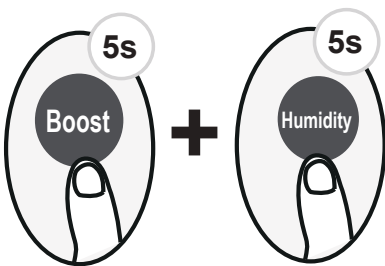

Press together **Boost** button and **Humidity** button at the same time more than 5 seconds to activate Lock function. All buttons will not response except pressing these two buttons for two seconds again to disable locking.

BOOST Function

Press Boost button



When you select Boost feature in COOL mode, the unit will blow cool air with strongest wind setting to jump-start the cooling process.

When you select Boost feature in HEAT mode, for units with Electric heat elements, the Electric HEATER will activate and jump-start the heating process.

SET function

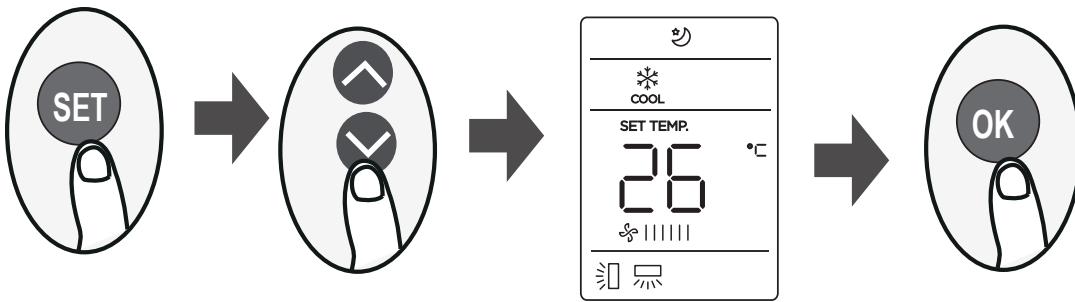

- Press the SET button to enter the function setting, then press SET button or TEMP▼ or TEMP▲ button to select the desired function. The selected symbol will flash on the display area, press the OK button to confirm.
- To cancel the selected function, just perform the same procedures as above.
- Press the SET button to scroll through operation functions as follows:
 Active clean () → Fresh* () → Sleep () → Follow Me () → AP mode* () → Active clean ()....
 [*]: Model dependent

Active clean function () (some units) :

The Active Clean Technology washes away dust, mold, and grease that may cause odors when it adheres to the heat exchanger by automatically freezing and then rapidly thawing the frost. When this function is turned on, the indoor unit display window appears “CL”, after 20 to 45 minutes, the unit will turn off automatically and cancel CLEAN function.

FRESH function () (some units) :

When the FRESH function is initiated, the Ionizer/Plasma Dust Collector (depending on models) is energised and will help to remove pollen and impurities from the air

Sleep function () :

The SLEEP function is used to decrease energy use while you sleep (and don't need the same temperature settings to stay comfortable). This function can only be activated via remote control.

For details, see “Sleep Operation” in the ‘USER’S MANUAL.

Note: The SLEEP function is not available in FAN or DRY mode.

Follow me function () :

The FOLLOW ME function enables the remote control to measure the temperature at its current location and send this signal to the air conditioner every 3 minutes interval. When using AUTO, COOL or HEAT modes, measuring ambient temperature from the remote control (instead of from the indoor unit itself) will enable the air conditioner to optimize the temperature around you and ensure maximum comfort.

NOTE: Press and hold Boost button for seven seconds to start/stop memory feature of Follow Me function.





- If the memory feature is activated, “On” displays for 3 seconds on the screen.
- If the memory feature is stopped, “Of” displays for 3 seconds on the screen.
- While the memory feature is activated, press the ON/OFF button, shift the mode or power failure will not cancel the Follow me function.

AP function () (some units) :

Choose AP mode to do wireless network configuration. For some units, it doesn't work by pressing the SET button. To enter the AP mode, continuously press the LED button seven times in 10 seconds.

ACCESSORIES

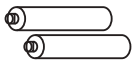
The air conditioning system comes with the following accessories. Use all of the installation parts and accessories to install the air conditioner. Improper installation may result in water leakage, electrical shock and fire, or cause the equipment to fail. The items are not included with the air conditioner must be purchased separately.

Name of Accessories	Q'ty(pc)	Shape
Manual	2~4	
Remote controller (some models)	1	
Battery (some models)	2	
Copper Nut	2	

Optional accessories

- There are two types of remote controls: wired and wireless.
Select a remote controller based on customer preferences and requirements and install in an appropriate place.
Refer to catalogues and technical literature for guidance on selecting a suitable remote controller.

Name	Outer Pipe Diameter (mm)	
Connecting pipe assembly	Liquid side	Φ 6.35
	Gas side	Φ 12.7

INSTALLATION SUMMARY

Indoor Unit

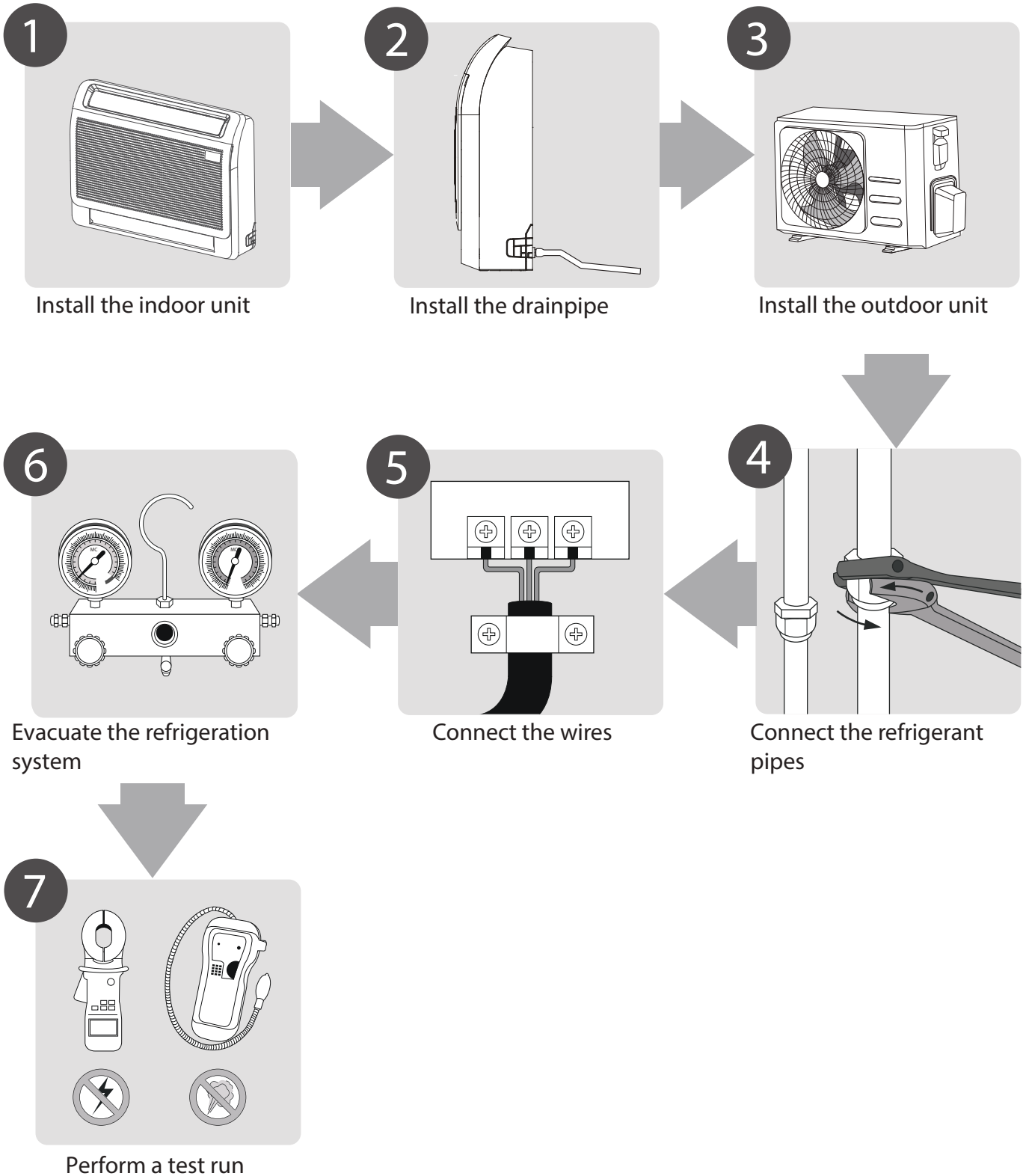

DESCRIPTION

NOTE: The installation must be performed in accordance with the requirement of local and national standards. The installation may be slightly different in different areas.

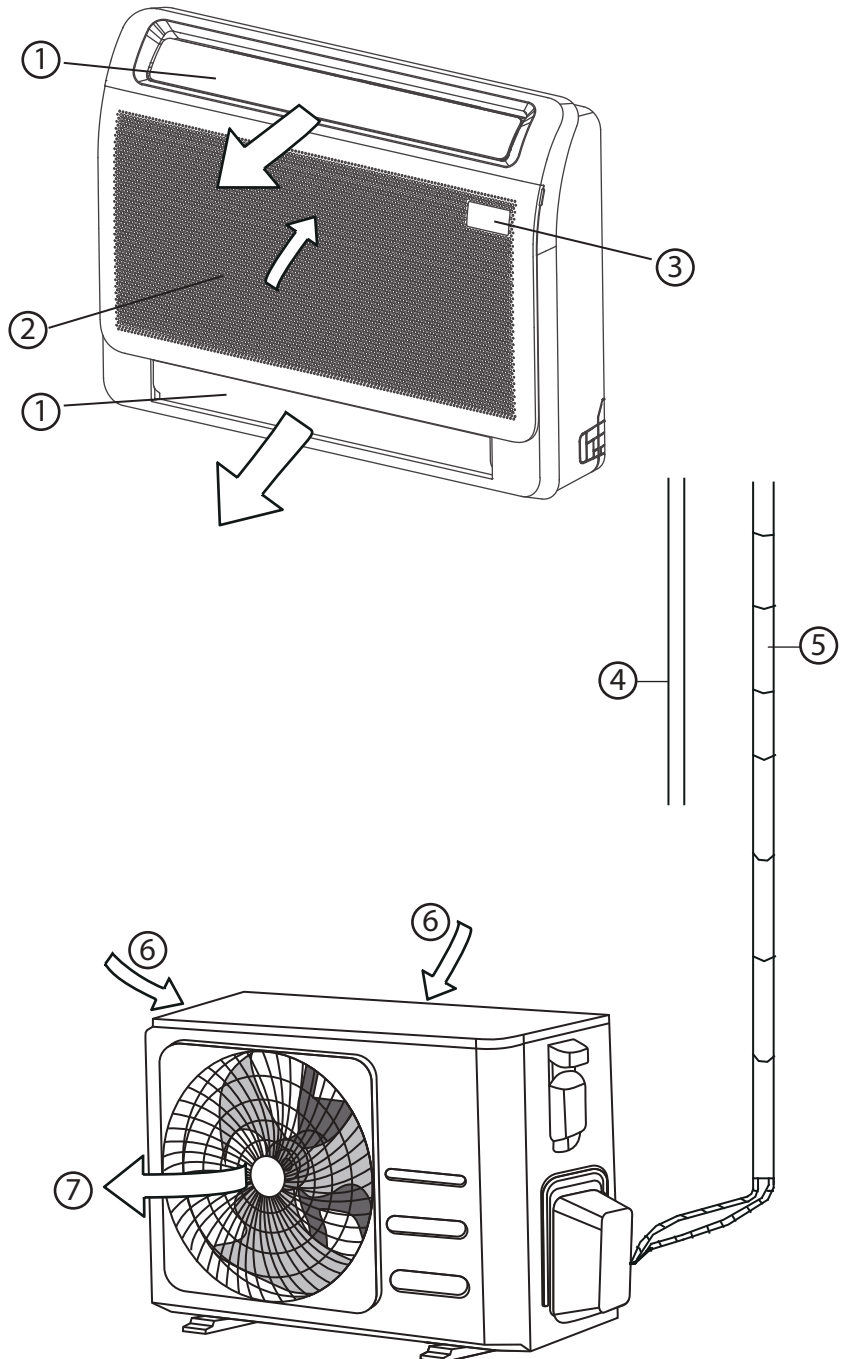

- ① Air flow louver (at air outlet)
- ② Air inlet (with air filter in it)
- ③ Display panel
- ④ Drain pipe

- ⑤ Connecting pipe
- ⑥ Air inlet
- ⑦ Air outlet

NOTE ON ILLUSTRATIONS

- The piping can be connected from the left, right, rear and lower sides of the unit. Please select the piping method according to the actual demand.
- Illustrations in this manual are for explanatory purposes. The actual shape of your indoor unit may be slightly different. The actual shape shall prevail.

INDOOR INSTALLATION

Installation Instructions – Indoor Unit

NOTE: Panel installation should be performed after piping and wiring have been completed.

Step 1: Select installation location

Before installing the indoor unit, you must choose an appropriate location. The following are standards that will help you choose an appropriate location for the unit.

Proper installation locations meet the following standards:

- ☑ Enough room exists for installation and maintenance.
 - ☑ Enough room exists for the connecting the pipe and drainpipe.
 - ☑ The ceiling is horizontal and its structure can sustain the weight of the indoor unit.
 - ☑ The air inlet and outlet are not blocked.
 - ☑ The airflow can fill the entire room.
 - ☑ There is no direct radiation from heaters.
- DO NOT** install unit in the following locations:
- ⊘ Areas with oil drilling or fracking
 - ⊘ Coastal areas with high salt content in the air
 - ⊘ Areas with caustic gases in the air, such as hot springs
 - ⊘ Areas that experience power fluctuations, such as factories
 - ⊘ Enclosed spaces, such as cabinets
 - ⊘ Kitchens that use natural gas
 - ⊘ Areas with strong electromagnetic waves
 - ⊘ Areas that store flammable materials or gas
 - ⊘ Rooms with high humidity, such as bathrooms or laundry rooms

Recommended distances between the indoor unit

The distance between the mounted indoor unit should meet the specifications illustrated in the following diagram.

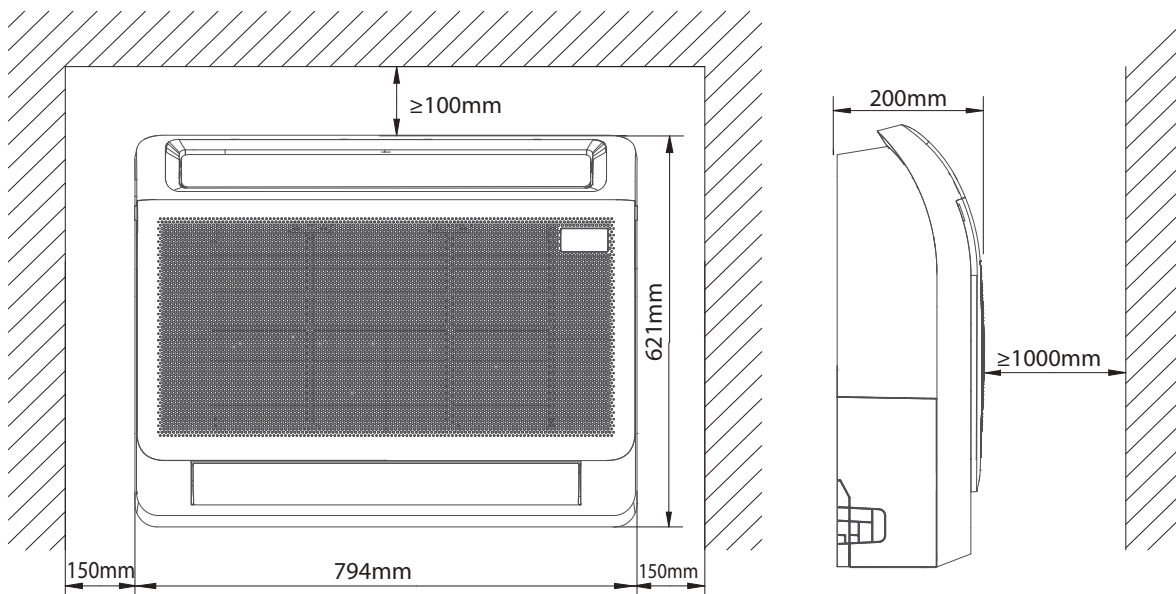

Step 2: Installing the main body

- After loosening the screws, remove the mounting plate from the unit.

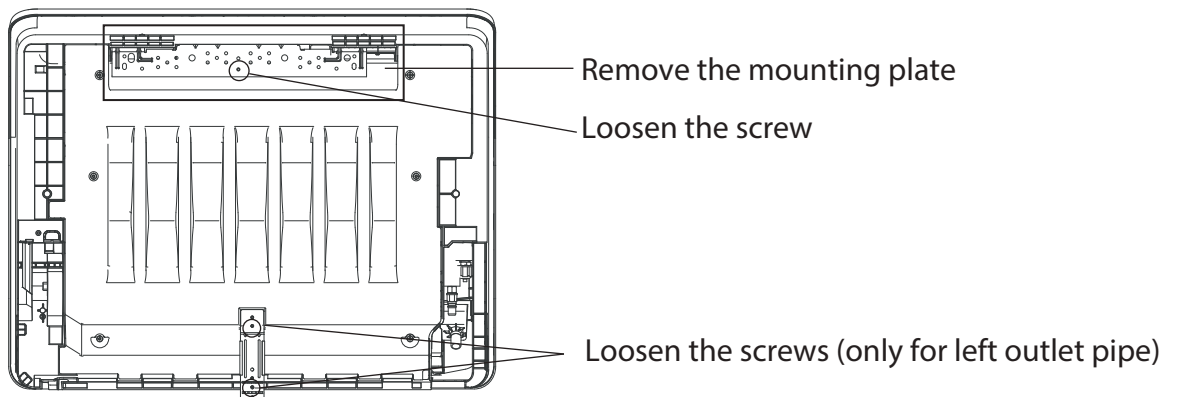

NOTE: If the pipe comes out on the left, it is necessary to loosen the screws on the bottom mounting plate. If the pipe comes out in other directions, it is not necessary.

- Fix the mounting plate with a tapping screw onto the wall.
NOTE: It is recommended to fix it on the wall according to the hanging hole indicated by the arrow on the mounting plate. Mounting plate must be installed horizontally.

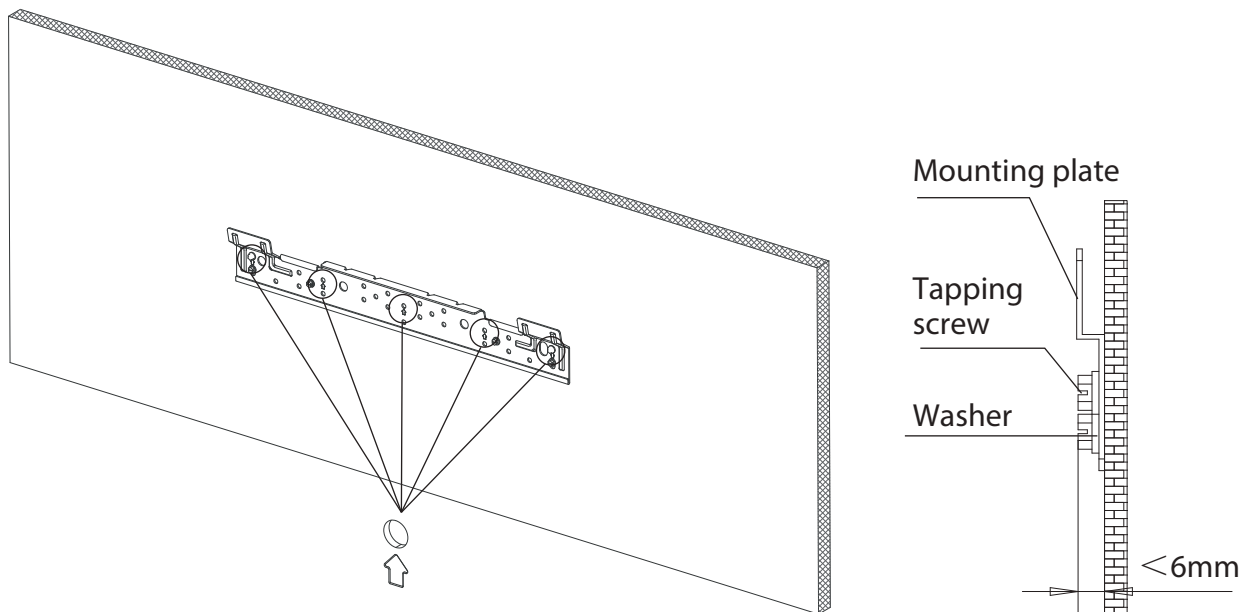

- Hang the indoor unit on the mounting plate.
(The bottom of body can touch the floor or remain suspended, but the body must be installed vertically.)

NOTE: After installation, the unit shall be kept horizontal without tilting.

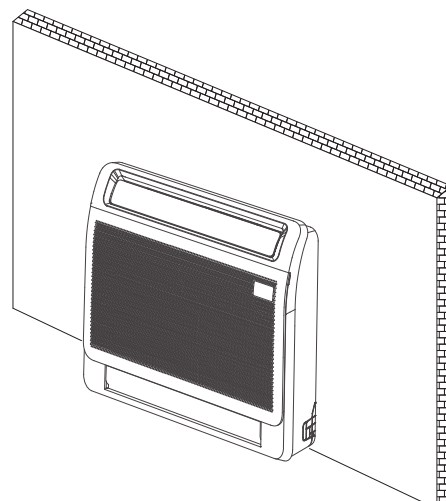

• Bottom mounting plate installation

Installation without skirting

The bottom mounting plate is fixed directly to the wall.

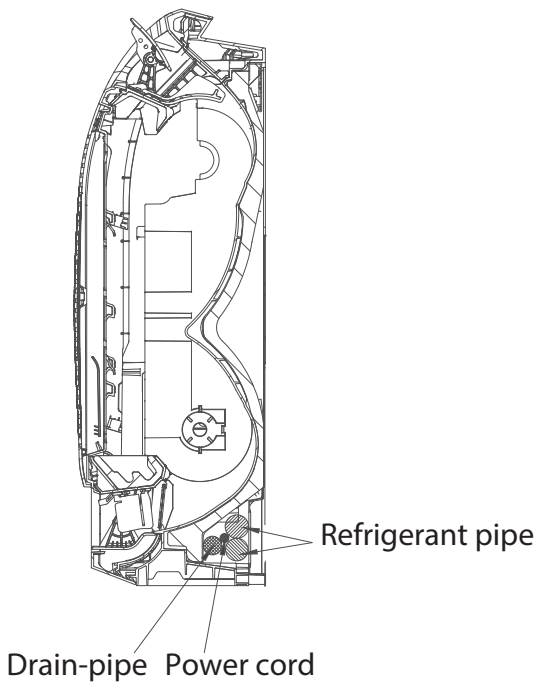
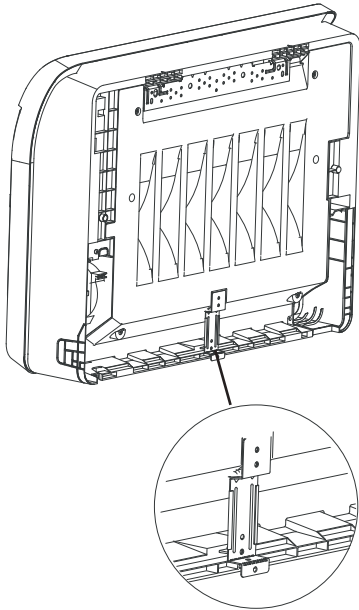

NOTE: In order to drain smoothly, the position of the drain pipe must refer to the above figure when discharging the right pipe.

Installation with skirting line

Knock the bottom mounting plate straight with a tool and fix it on the skirting line.

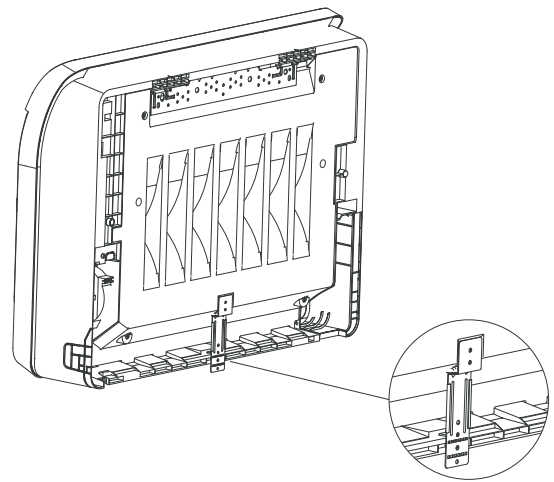
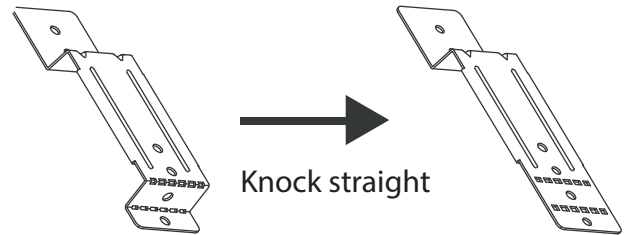

Step 3: Taking the indoor unit apart to connect the pipes

1. Open the bottom piping cover plate

Press and hold the bottom two buckles, and then rotate to open the piping cover plate.

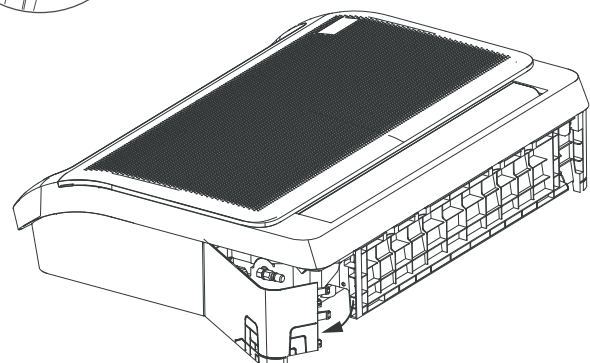
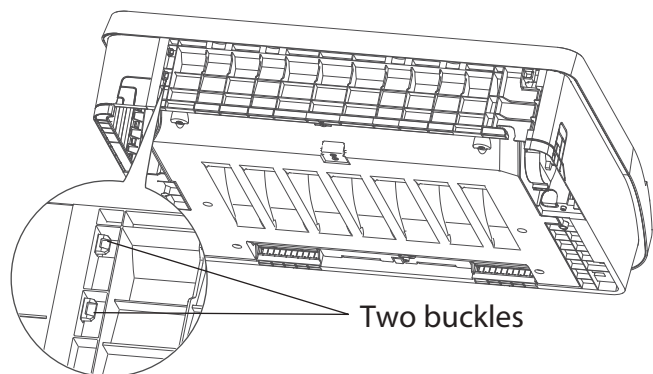

2. Remove the cover plate.

Remove the pipe cover plate and install the internal and external connecting pipes.

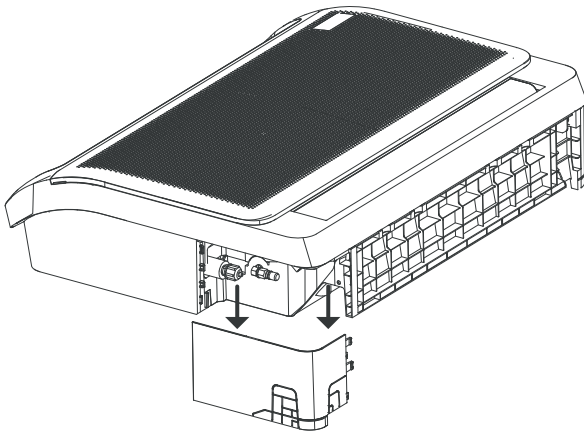

NOTE: Install small-size piping first, and then large-size piping.

NOTE: All the figures in this manual are for demonstration purposes only. The air conditioner you have purchased may be slightly different in design, though similar in shape.

Step 4: Network address set (some models)

(Only for the case of optional multi-function board with XYE interface.)

Every air-conditioner in network has only one network address to distinguish each other. Address code of air-conditioner in LAN is set by code switches F1 & ENC3 on the multifunction board of the indoor unit, and the set range is 0-63. (Optional multi-function board)

Toggle switch set			Network address code	
F1	ENC3			
		~		00~15
		~		16~31
		~		32~47
		~		48-63

Step 5: Drill wall hole for connective piping

1. Determine the location of the wall hole based on the location of the outdoor unit.
2. Using a 65mm or 90mm (depending on models) core drill, drill a hole in the wall. Make sure that the hole is drilled at a slight downward angle, so that the outdoor end of the hole is lower than the indoor end by about 12mm. This will ensure proper water drainage.
3. Place the protective wall cuff in the hole. This protects the edges of the hole and will help seal it when you finish the installation process.

CAUTION

When drilling the wall hole, make sure to avoid wires, plumbing, and other sensitive

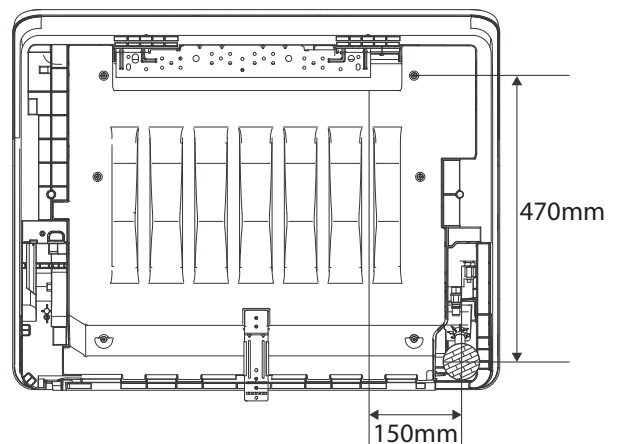
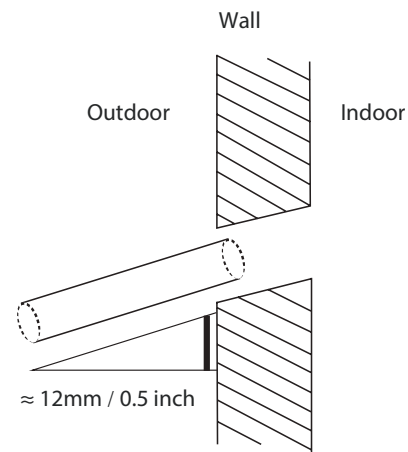

Recommended position and size of back outlet pipe through wall hole

Step 6: Connect drain hose

The drainpipe is used to drain water away from the unit. Improper installation may cause unit and property damage.

CAUTION

- Insulate all piping to prevent condensation, which could lead to water damage.
- If the drainpipe is bent or installed incorrectly, water may leak and cause a water-level switch malfunction.
- In HEAT mode, the outdoor unit will discharge water. Ensure that the drain hose is placed in an appropriate area to avoid water damage and slippage.
- **DO NOT** pull the drainpipe forcefully. This could disconnect it.

NOTE ON PURCHASING PIPES

Installation requires a polyethylene tube (exterior diameter = 3.7-3.9cm, interior diameter = 3.2cm), which can be obtained at your local hardware store or dealer.

1. Cover the drainpipe with heat insulation to prevent condensation and leakage.
2. Attach the mouth of the drain hose to the unit's outlet pipe. Sheath the mouth of the hose and clip it firmly with a pipe clasp.

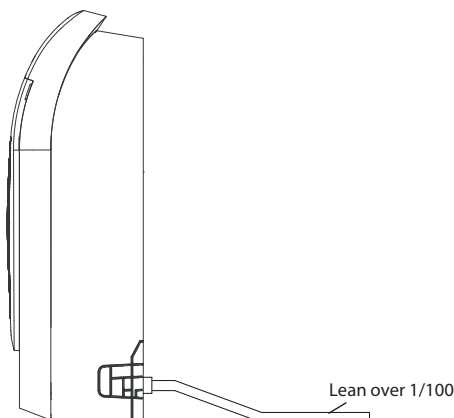
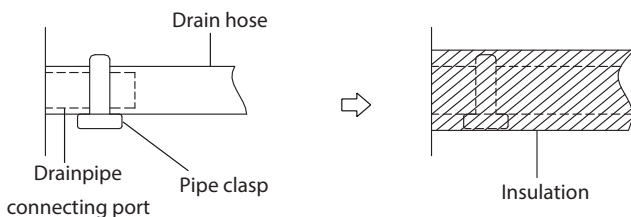

NOTE ON DRAINPIPE INSTALLATION

- When using an extended drainpipe, tighten the indoor connection with an additional protection tube. This prevents it from pulling loose.
- The drainpipe should slope downward at a gradient of at least 1/100 to prevent water from flowing back into the air conditioner.
- Incorrect installation could cause water to flow back into the unit and flood.

NOTE: When connecting multiple drainpipes, install the pipes as illustrated.

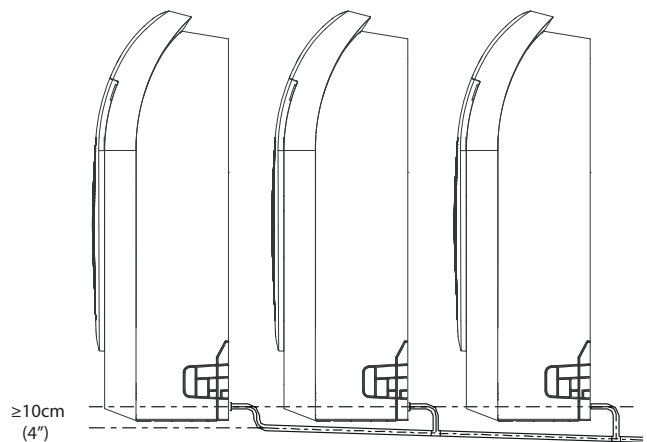

In order to ensure smooth drainage, the height difference between the wall outlet and the hanging plate must be greater than 470mm.

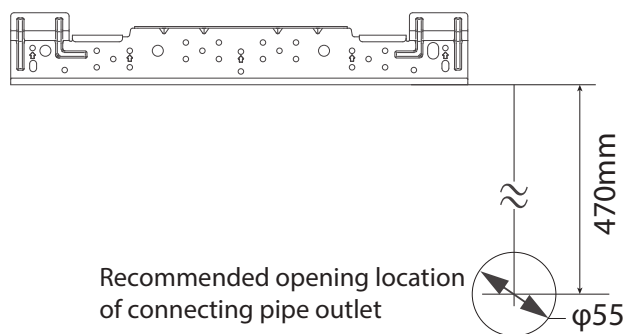

Drainage pipe fixing requirements

When installing the drainage pipe (not provided), please fix it with a tie or rope.

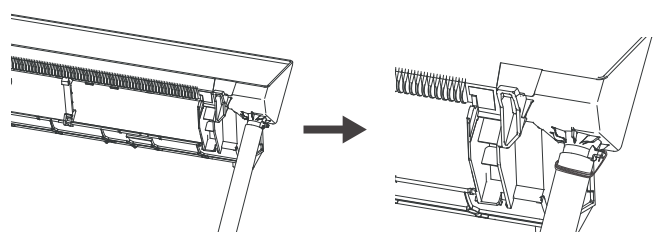

OUTDOOR INSTALLATION

Installation Instructions – Outdoor Unit

Install the unit by following your Local Regulations and Municipal Building Codes. They may differ slightly between states.

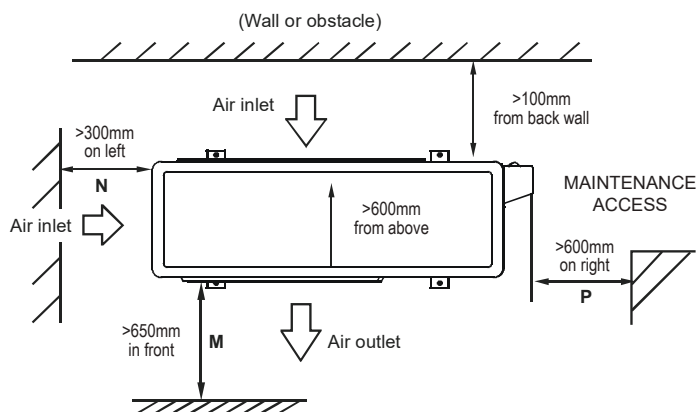

Step 1: Select installation location

Before installing the outdoor unit, you must choose an appropriate location. The following are standards that will help you choose an appropriate location for the unit.

Proper installation locations meet the following standards:

- Meets all spatial requirements shown in Installation Space Requirements above.
- Good air circulation and ventilation
- Firm and solid—the location can support the unit and will not vibrate
- Noise from the unit will not disturb others
- Protected from prolonged periods of direct sunlight or rain
- Where snowfall is anticipated, take appropriate measures to prevent ice buildup and coil damage.

DO NOT install unit in the following locations:

- Near an obstacle that will block air inlets and outlets
- Near a public street, crowded areas, or where noise from the unit will disturb others
- Near animals or plants that will be harmed by hot air discharge
- Near any source of combustible gas
- In a location that is exposed to large amounts of dust
- In a location exposed to a excessive amounts of salty air

SPECIAL CONSIDERATIONS FOR EXTREME WEATHER

If the unit is exposed to heavy wind:

Install unit so that air outlet fan is at a 90° angle to the direction of the wind. If needed, build a barrier in front of the unit to protect it from extremely heavy winds. See Figures below.

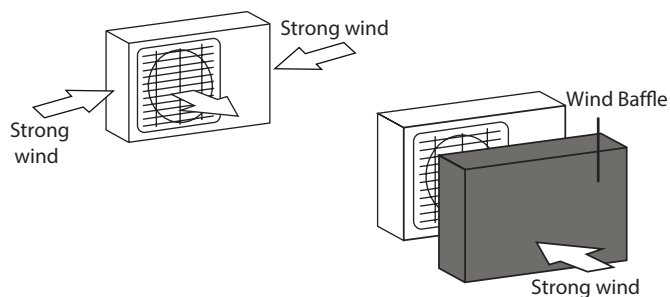

If the unit is frequently exposed to heavy rain or snow:

Build a shelter above the unit to protect it from the rain or snow. Be careful not to obstruct air flow around the unit.

If the unit is frequently exposed to salty air (seaside):

Use outdoor unit that is specially designed to resist corrosion.

Step 2: Install drain joint (Heat pump unit only)

Before bolting the outdoor unit in place, you must install the drain joint at the bottom of the unit. Note that there are two different types of drain joints depending on the type of outdoor unit.

If the drain joint comes with a rubber seal (see Fig. A), do the following:

1. Fit the rubber seal on the end of the drain joint that will connect to the outdoor unit.
2. Insert the drain joint into the hole in the base pan of the unit.
3. Rotate the drain joint 90° until it clicks in place facing the front of the unit.
4. Connect a drain hose extension (not included) to the drain joint to redirect water from the unit during heating mode.

If the drain joint doesn't come with a rubber seal (see Fig. B), do the following:

1. Insert the drain joint into the hole in the base pan of the unit. The drain joint will click in place.
2. Connect a drain hose extension (not included) to the drain joint to redirect water from the unit during heating mode.

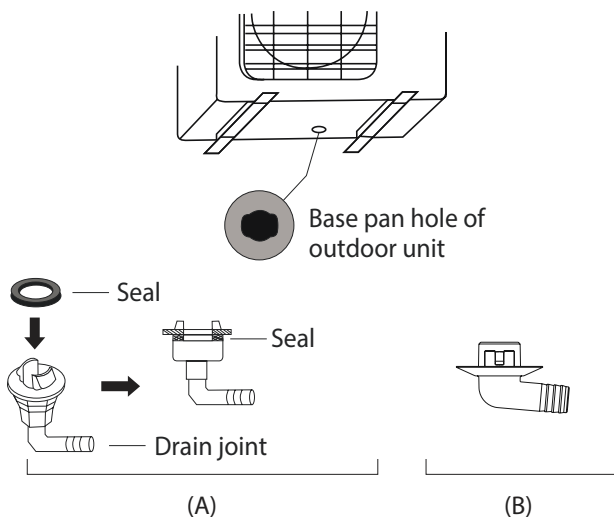

Step 3: Anchor outdoor unit

The outdoor unit can be anchored to the ground or to a wall-mounted bracket with bolt(M10). Prepare the installation base of the unit according to the dimensions below.

UNIT MOUNTING DIMENSIONS

The following is a list of different outdoor unit sizes and the distance between their mounting feet. Prepare the installation base of the unit according to the dimensions below.

Outdoor Unit Types and Specifications

Split Type Outdoor Unit

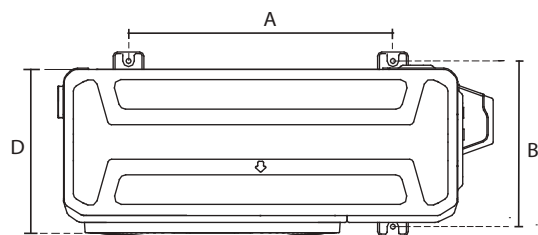
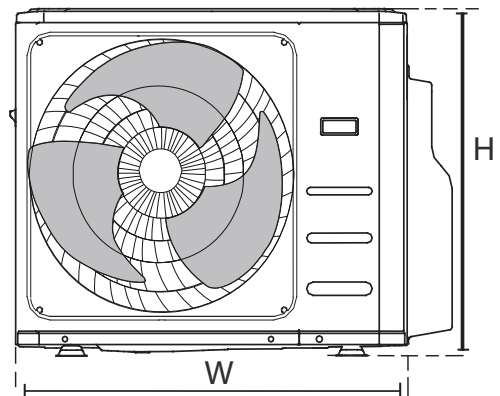

! IN COLD CLIMATES

In cold climates, make sure that the drain hose is as vertical as possible to ensure swift water drainage. If water drains too slowly, it can freeze in the hose and flood the unit.

Outdoor Unit Dimensions (mm) W x H x D	Mounting Hole Pitch Dimensions	
	Pitch A (mm)	Pitch B (mm)
890 x 673 x 342	663	354

Rows of series installation

The relations between H, A and L are as follows.

	L	A
L ≤ H	L ≤ 1/2H	25 cm or more
	1/2H < L ≤ H	30 cm or more
L > H	Can not be installed	

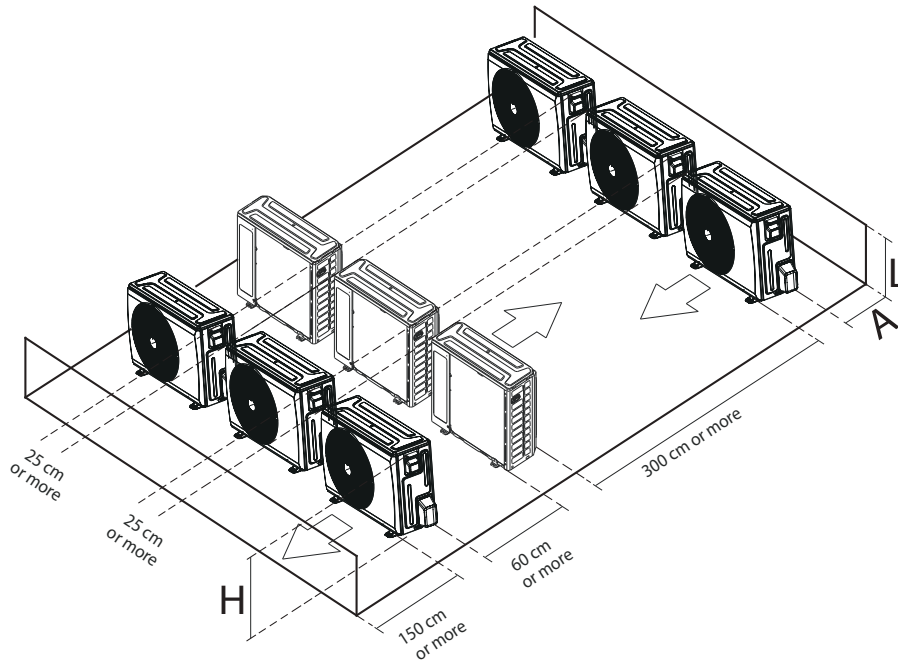

REFRIGERANT PIPING CONNECTION

When connecting refrigerant piping, do not let substances or gases other than the specified refrigerant enter the unit. The presence of other gases or substances will lower the unit's capacity, and can cause abnormally high pressure in the refrigeration cycle. This can cause explosion and injury.

Note on Pipe Length

Ensure that the length of the refrigerant pipe, the number of bends, and the drop height between the indoor and outdoor units meets the requirements shown in the following table :

The Maximum Length and Drop Height Based on Models

Model	Capacity (kW)	Pipe Length (m)	Max Drop Height (m)
Conversion Split Type Air Conditioner	<4.4	25	10
	≥4.4 and <7	30	20
	≥7 and <10.5	50	25

⚠ CAUTION

Mark the data plate with the Orifice installed (for some models).

- Please purchase the fittings according to the requirements in the manual strictly.
- Refer the diagram when installing.

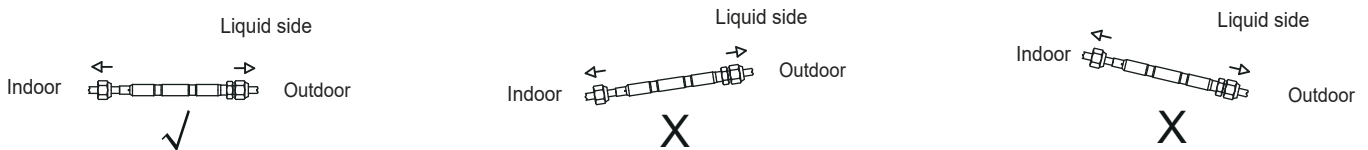

⚠ CAUTION

Oil traps

If oil flows back into the outdoor unit's compressor, this might cause liquid compression or deterioration of oil return. Oil traps in the rising gas piping can prevent this.

An oil trap should be installed every 6m of vertical suction line riser (< 10.5kW unit).

An oil trap should be installed every 10m of vertical suction line riser (≥10.5kW unit).

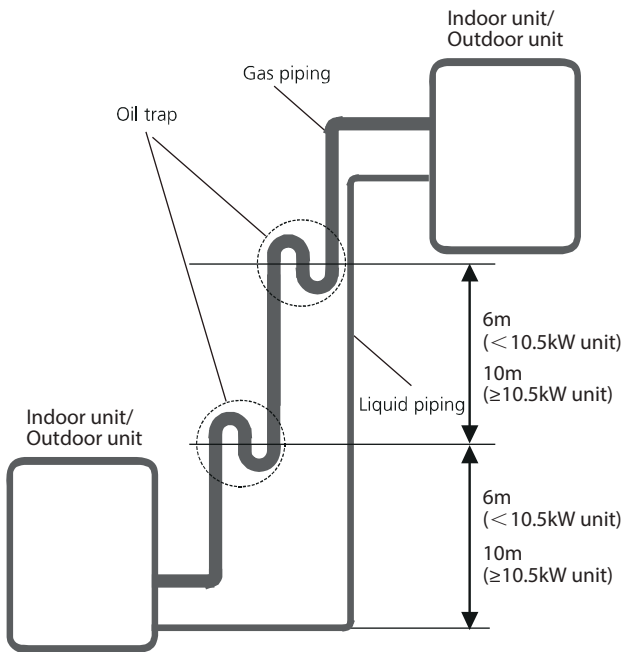

Connection Instructions – Refrigerant Piping

⚠ CAUTION

- The branching pipe must be installed horizontally. An angle of more than 10° may cause malfunction.
- DO NOT install the connecting pipe until both indoor and outdoor units have been installed.
- Insulate both the gas and liquid piping to prevent water leakage.

Step 1: Cut pipes

When preparing refrigerant pipes, take extra care to cut and flare them properly. This will ensure efficient operation and minimise the need for future maintenance.

1. Measure the distance between the indoor and outdoor units.
2. Using a pipe cutter, cut the pipe a little longer than the measured distance.
3. Make sure that the pipe is cut at a perfect 90° angle.

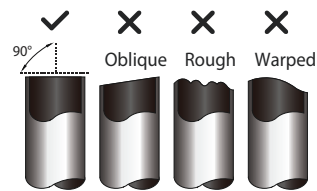

⚠ DO NOT DEFORM PIPE WHILE CUTTING

Take care not to damage, dent, or deform the pipe while cutting. This may adversely affect the heating efficiency of the unit.

Step 2: Remove burrs.

Burrs can affect the air-tight seal of refrigerant piping connection. They must be completely removed.

1. Hold the pipe at a downward angle to prevent burrs from falling into the pipe.

- Using a reamer or deburring tool, remove all burrs from the cut section of the pipe.

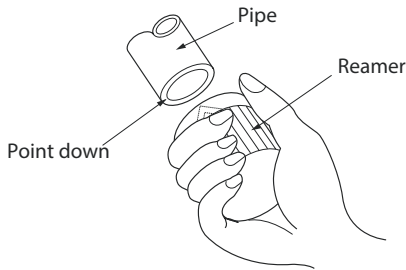

Step 3: Flare pipe ends

Proper flaring is essential to achieve an airtight seal.

- After removing burrs from cut pipe, seal the ends with PVC tape to prevent foreign materials from entering the pipe.
- Sheath the pipe with insulating material.
- Place flare nuts on both ends of pipe. Make sure they are facing in the right direction, because you can't put them on or change their direction after flaring.

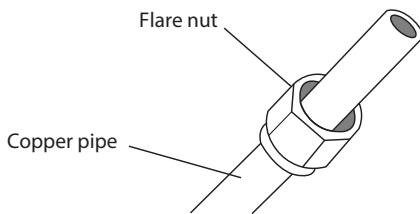

- Remove PVC tape from ends of pipe when ready to perform flaring work.
- Clamp flare form on the end of the pipe. The end of the pipe must extend beyond the flare form.

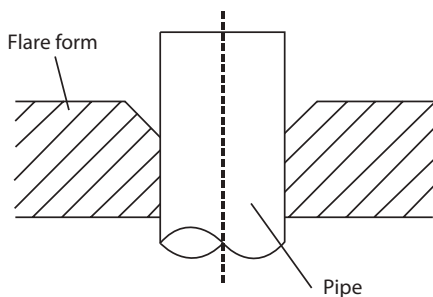

- Place flaring tool onto the form.
- Turn the handle of the flaring tool clockwise until the pipe is fully flared. Flare the pipe in accordance with the dimensions.

PIPING EXTENSION BEYOND FLARE FORM

Pipe gauge	Tightening torque	Flare dimension (A) (Unit: mm)		Flare shape
		Min.	Max.	
Ø 6.35	18-20 N.m (180-200 kgf.cm)	8.4	8.7	
Ø 9.52	32-39 N.m (320-390 kgf.cm)	13.2	13.5	
Ø 12.7	49-59 N.m (490-590 kgf.cm)	16.2	16.5	
Ø 16	57-71 N.m (570-710 kgf.cm)	19.2	19.7	
Ø 19	67-101 N.m (670-1010 kgf.cm)	23.2	23.7	
Ø 22	85-110 N.m (850-1100 kgf.cm)	26.4	26.9	

- Remove the flaring tool and flare form, then inspect the end of the pipe for cracks and even flaring.

Step 4: Connect pipes

Connect the copper pipes to the indoor unit first, then connect it to the outdoor unit. You should first connect the low-pressure pipe, then the high-pressure pipe.

- When connecting the flare nuts, apply a thin coat of refrigeration oil to the flared ends of the pipes.
- Align the center of the two pipes that you will connect.

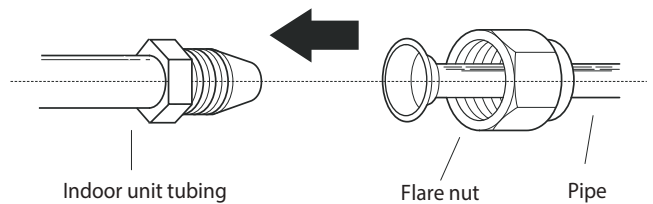

- Tighten the flare nut as tightly as possible by hand.
- Using a spanner, grip the nut on the unit tubing.

5. While firmly gripping the nut, use a torque wrench to tighten the flare nut according to the torque values in above table.

NOTE: Use both a spanner and a torque wrench when connecting or disconnecting pipes to/from the unit.

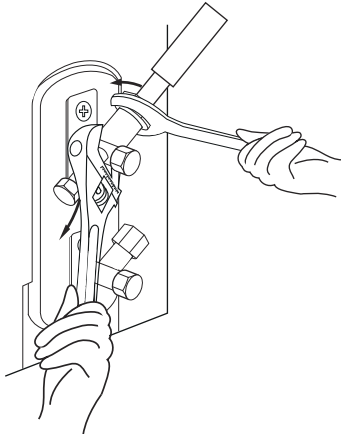

! CAUTION

- Ensure to wrap insulation around the piping. Direct contact with the bare piping may result in burns or frostbite.
- Make sure the pipe is properly connected. Over tightening may damage the bell mouth and under tightening may lead to leakage.

NOTE ON MINIMUM BEND RADIUS

Carefully bend the tubing in the middle according to the diagram below. **DO NOT** bend the tubing more than 90° or more than 3 times.

Bend the pipe with thumb

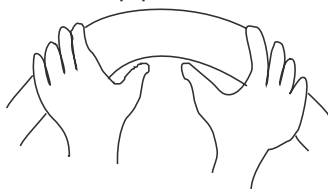

min-radius 10cm

6. After connecting the copper pipes to the indoor unit, wrap the power cable, signal cable and the piping together with binding tape.

NOTE: DO NOT intertwine signal cable with other wires. While bundling these items together, do not intertwine or cross the signal cable with any other wiring.

7. Thread this pipeline through the wall and connect it to the outdoor unit.
8. Insulate all the piping, including the valves of the outdoor unit.
9. Open the stop valves of the outdoor unit to start the flow of the refrigerant between the indoor and outdoor unit.

! CAUTION

Check to make sure there is no refrigerant leak after completing the installation work. If there is a refrigerant leak, ventilate the area immediately and evacuate the system (refer to the Air Evacuation section of this manual).

NOTE: After connecting the piping, please wrap the connecting pipe head with the insulation pipe in the accessory package.

WIRING

! BEFORE PERFORMING ANY ELECTRICAL WORK, READ THESE REGULATIONS

1. All wiring must comply with local and national electrical codes, regulations and must be installed by a licensed electrician.
2. All electrical connections must be made according to the Electrical Connection Diagram located on the panels of the indoor and outdoor units.
3. If there is a serious safety issue with the power supply, stop work immediately. Explain your reasoning to the client, and refuse to install the unit until the safety issue is properly resolved.
4. Power voltage should be within 90-110% of rated voltage. Insufficient power supply can cause malfunction, electrical shock, or fire.
5. If connecting power to fixed wiring, a surge protector and main power switch should be installed.
6. If connecting power to fixed wiring, a switch or circuit breaker that disconnects all poles and has a contact separation of at least 3mm must be incorporated in the fixed wiring. The qualified technician must use an approved circuit breaker or switch.
7. Only connect the unit to an individual branch circuit outlet. Do not connect another appliance to that outlet.
8. Make sure to properly ground the air conditioner.
9. Every wire must be firmly connected. Loose wiring can cause the terminal to overheat, resulting in product malfunction and possible fire.
10. Do not let wires touch or rest against refrigerant tubing, the compressor, or any moving parts within the unit.
11. If the unit has an auxiliary electric heater, it must be installed at least 1 metre away from any combustible materials.
12. To avoid getting an electric shock, never touch the electrical components soon after the power supply has been turned off. After turning off the power, always wait 10 minutes or more before you touch the electrical components.

13. Make sure that you do not cross your electrical wiring with your signal wiring. This may cause distortion and interference.
14. The unit must be connected to the main outlet. Normally, the power supply must have an impedance of 32 ohms.
15. No other equipment should be connected to the same power circuit.
16. Connect the outdoor wires before connecting the indoor wires.

! WARNING

BEFORE PERFORMING ANY ELECTRICAL OR WIRING WORK, TURN OFF THE MAIN POWER TO THE SYSTEM.

NOTE ON AIR SWITCH

When the maximum current of the air conditioner is more than 16A, an air switch or leakage protection switch with protective device shall be used (purchased separately). When the maximum current of the air conditioner is less than 16A, the power cord of air conditioner shall be equipped with plug (purchased separately).

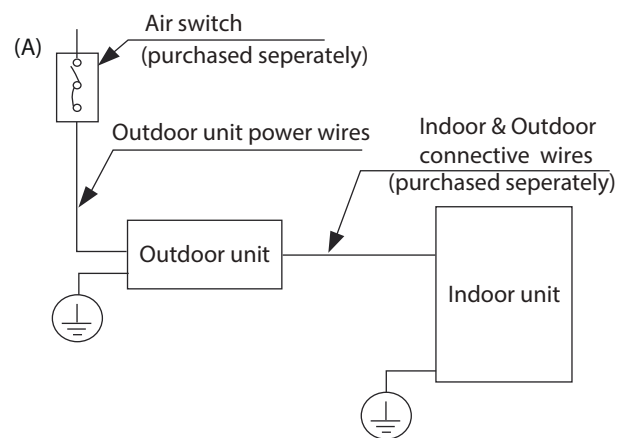

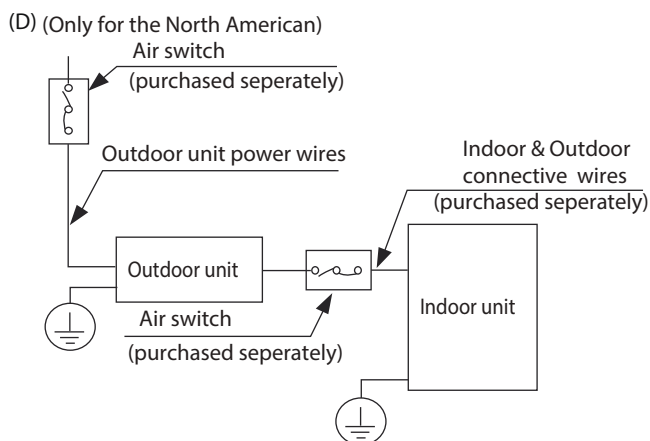
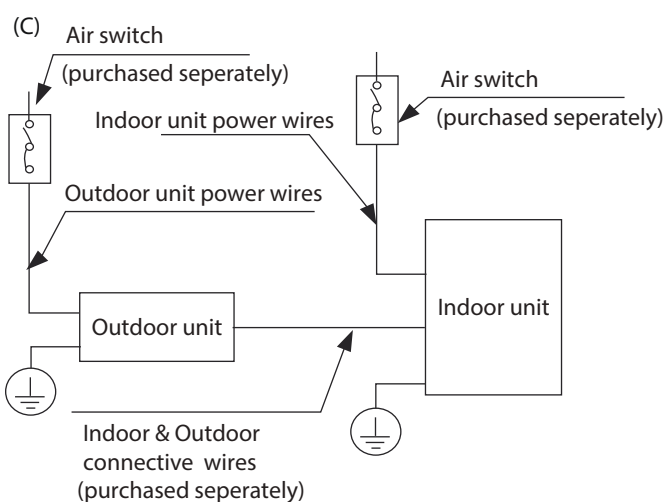
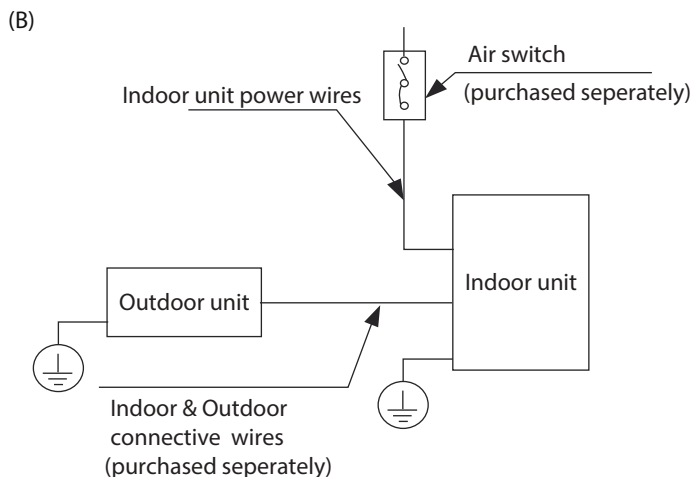

NOTE: The cognographs are for explanation purpose only. Your machine may be slightly different. The actual shape shall prevail.

Outdoor Unit Wiring

⚠ WARNING

Before performing any electrical or wiring work, turn off the main power to the system.

1. Prepare the cable for connection
 - a. You must first choose the right cable size. Be sure to use H07RN-F cables.
 - b. Using wire strippers, strip the rubber jacket from both ends of the signal cable to reveal approximately 15cm of wire.

Minimum Cross-Sectional Area of Power and Signal Cables (For reference)

Rated Current of Appliance (A)	Nominal Cross-Sectional Area (mm ²)
> 3 and ≤ 6	0.75
> 6 and ≤ 10	1
> 10 and ≤ 16	1.5
> 16 and ≤ 25	2.5
> 25 and ≤ 32	4
> 32 and ≤ 40	6

CHOOSE THE RIGHT CABLE SIZE

The size of the power supply cable, signal cable, fuse, and switch needed is determined by the maximum current of the unit. The maximum current is indicated on the nameplate located on the side panel of the unit. Refer to this nameplate to choose the right cable, fuse, or switch.

WIRING

- c. Strip the insulation from the ends.
- d. Using a wire crimper, crimp u-lugs on the ends.

NOTE: When connecting the wires, strictly follow the wiring diagram found inside the electrical box cover.

2. Remove the electric cover of the outdoor unit.
If there is no cover on the outdoor unit, take off the bolts from the maintenance board and remove the protection board.

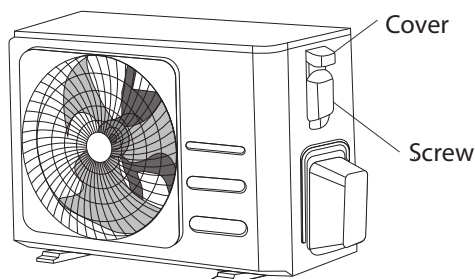

3. Connect the u-lugs to the terminals
Match the wire colors/labels with the labels on the terminal block. Firmly screw the u-lug of each wire to its corresponding terminal.
4. Clamp down the cable with the cable clamp.
5. Insulate unused wires with electrical tape.
Keep them away from any electrical or metal parts.
6. Reinstall the cover of the electric control box.

Indoor Unit Wiring

1. Prepare the cable for connection
 - a. Using wire strippers, strip the rubber jacket from both ends of the signal cable to reveal about 15cm of the wire.
 - b. Strip the insulation from the ends of the wires.
 - c. Using a wire crimper, crimp the u-lugs to the ends of the wires.
2. Pull the left and right handles of the front panel, pull the panel outward, and open the panel.

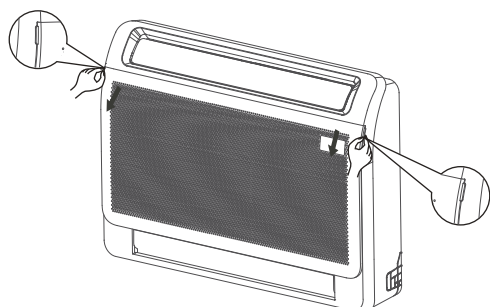

3. Remove the electric control box.
Connect the u-lugs to the terminals.
Match the wire colors/labels with the labels on the terminal block, Firmly screw the u-lug of each wire to its corresponding terminal. Refer to the Serial Number and Wiring Diagram located on the cover of the electric control box.

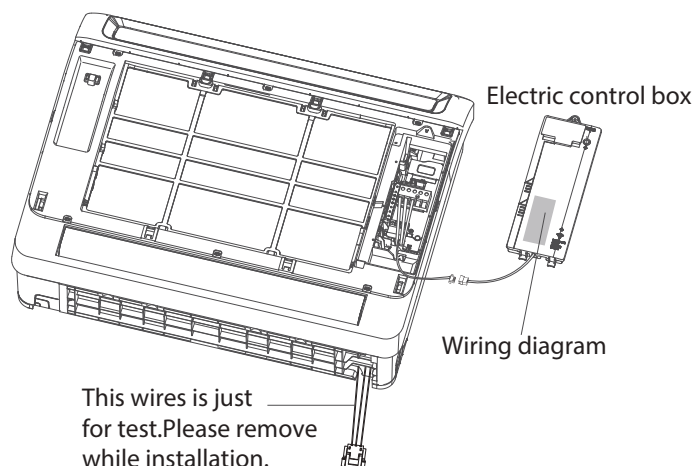

NOTE: When taking out the electric control box, pay attention to loosen and remove the terminal.

Magnetic ring (if supplied and packed with the accessories)

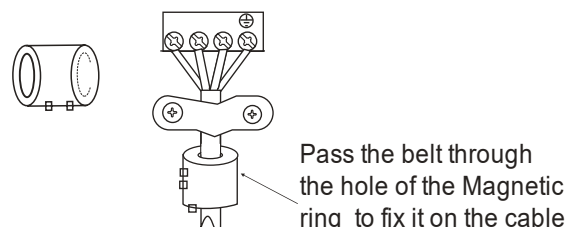

CAUTION

- Illustrations in this manual are for explanatory purposes. The actual shape shall prevail.
- While connecting the wires, please strictly follow the wiring diagram.
- The refrigerant circuit can become very hot. Keep the interconnection cable away from the copper tube.

4. Clamp down cable with the designated cable clamp to secure it in place. The cable should not be loose, and should not pull on the u-lugs.
Reinstall the electric box cover and the front panel of the indoor unit.

SPECIFICATIONS

Floor Console Single Split System			FSNRP50B
Power Supply		V-Ph-Hz	220-240V, 1Ph, 50Hz
Cooling (Standard conditions)	Rated Capacity	kW	4.90
	Rated Power Input	W	1340
	Rated Current (Range)	A	5.95
	AEER	W/W	3.636
	TCSPF (Hot/Mixed/Cold)		6.121 / 5.793 / 6.075
	Star Rating (Hot/Mixed/Cold)		4.5 / 4 / 4.5
Heating (Standard conditions)	Rated Capacity	kW	5.50
	Rated Power Input	W	1300
	Rated Current Range	A	5.94
	ACOP	W/W	4.207
	HSPF (Hot/Mixed/Cold)		4.982 / 4.416 / 3.79
	Star Rating (Hot/Mixed/Cold)		3 / 2.5 / 2
Indoor Unit Model No.			FINRP50MB
Sound Power Level		dB(A)	54
Indoor Unit	Dimensions (W x D x H)	mm	794 x 200 x 621
	Packing (W x D x H)	mm	865 x 280 x 719
	Net / Gross Weight	kg	14.9 / 18.8
Outdoor Unit Model No.			HONRP50B
Sound Power Level		dB(A)	64.2
Outdoor Unit	Dimensions (W x D x H)	mm	890 x 342 x 673
	Packing (W x D x H)	mm	995 x 398 x 740
	Net / Gross Weight	kg	38.3 / 41.4
Refrigerant Type / Charged Volume		kg	R32 / 1.26
Refrigerant Piping	Liquid Side/ Gas side	mm	6.35mm / 12.7mm
	Max. Refrigerant Pipe Length	m	30
	Max. Difference in Level	m	20

Capacities tested in accordance with AS/NZS 3823.1, with 5m interconnecting pipe length. With our policy of continuous improvement, we reserve the right to change, or discontinue at any time, specifications or designs without notice.

Power Specifications

MODEL (kW/h)		<4.7	4.7~5.2K
POWER	PHASE	1 Phase	1 Phase
	FREQUENCY AND VOLT	220-240V~, 50Hz/60Hz	220-240V~, 50Hz/60Hz
CIRCUIT BREAKER/FUSE(A)		20/16	20/16
INDOOR UNIT POWER WIRING (mm ²)		---	---
INDOOR/OUTDOOR CONNECTING WIRING (mm ²)	OUTDOOR UNIT POWER WIRING	3x1.5	3x2.5
	STRONG ELECTRIC SIGNAL	4x1.0	4x1.0
	WEAK ELECTRIC SIGNAL	---	---
	GROUND WIRING	1.5	2.5

AIR EVACUATION

Preparations and Precautions

Air and foreign matter in the refrigerant circuit can cause abnormal rises in pressure, which can damage the air conditioner, reduce its efficiency, and cause injury. Use a vacuum pump and manifold gauge to evacuate the refrigerant circuit, removing any non-condensable gas and moisture from the system.

Evacuation should be performed upon initial installation and when unit is relocated.

BEFORE PERFORMING EVACUATION

- ✓ Check to make sure the connective pipes between the indoor and outdoor units are connected properly.
- ✓ Check to make sure all wiring is connected properly.

Evacuation Instructions

1. Connect the charge hose of the manifold gauge to service port on the outdoor unit's low pressure valve.
2. Connect another charge hose from the manifold gauge to the vacuum pump.
3. Open the Low Pressure side of the manifold gauge. Keep the High Pressure side closed.
4. Turn on the vacuum pump to evacuate the system.
5. Run the vacuum for at least 15 minutes, or until the Compound Meter reads -76cmHG (-10⁵Pa).

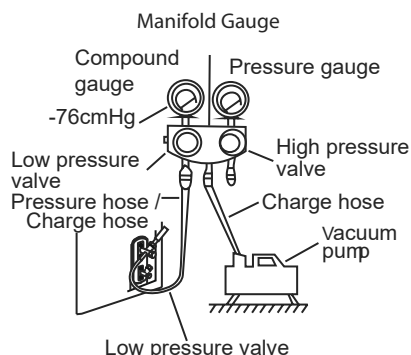

6. Close the Low Pressure side of the manifold gauge, and turn off the vacuum pump.
7. Wait for 5 minutes, then check that there has been no change in system pressure.

8. If there is a change in system pressure, refer to Gas Leak Check section for information on how to check for leaks. If there is no change in system pressure, unscrew the cap from the packed valve (high pressure valve).
9. Insert hexagonal wrench into the packed valve (high pressure valve) and open the valve by turning the wrench in a 1/4 counterclockwise turn. Listen for gas to exit the system, then close the valve after 5 seconds.
10. Watch the Pressure Gauge for one minute to make sure that there is no change in pressure. The Pressure Gauge should read slightly higher than atmospheric pressure.
11. Remove the charge hose from the service port.

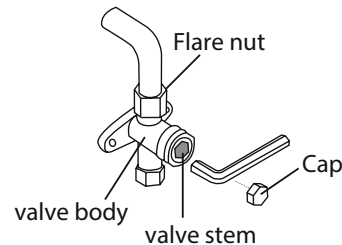

12. Using hexagonal wrench, fully open both the high pressure and low pressure valves.
13. Tighten valve caps on all three valves (service port, high pressure, low pressure) by hand. You may tighten it further using a torque wrench if needed.

! OPEN VALVE STEMS GENTLY

When opening valve stems, turn the hexagonal wrench until it hits against the stopper. Do not try to force the valve to open further.

Note on Adding Refrigerant

Some systems require additional charging depending on pipe lengths. The standard pipe length varies according to local regulations.

In other areas, the standard pipe length is 5m. The refrigerant should be charged from the service port on the outdoor unit's low pressure valve. The additional refrigerant to be charged can be calculated using the following formula:

Liquid Side Diameter

	φ6.35	φ9.52	φ12.7
R32 :	(Total pipe length - standard pipe length) x 12g/m	(Total pipe length - standard pipe length) x 24g/m	(Total pipe length - standard pipe length) x 40g/m

 **CAUTION** DO NOT mix refrigerant types.

- This unit contains factory charged refrigerant covering 20m of refrigerant piping and additional refrigerant charge on the installation site is not required for an installation with up to 20m refrigerant piping. When refrigerant piping exceeds 20m, additionally charge an amount calculated from the pipe length and the above table for the portion in excess of 20m.
- If an existing pipe system is used, a required refrigerant charge volume will vary depending on the liquid pipe size.

Formula to calculate the volume of additional refrigerant required :

Additional charge volume (kg) = { Main length (m) – Factory charged volume 20(m) } × 0.03(kg/m)

- Make sure to remove the additional refrigerant amount according to the nameplate rated charge (under 5m refrigerant piping) under market or government verification testing .

TEST RUN

Before Test Run

Electrical Safety Checks

A test run must be performed after the entire system has been completely installed. Confirm the following points before performing the test:

- a) Indoor and outdoor units are properly installed.
- b) Piping and wiring are properly connected.
- c) No obstacles near the inlet and outlet of the unit that might cause poor performance or product malfunction.
- d) Refrigeration system does not leak.
- e) Drainage system is unimpeded and draining to a safe location.
- f) Heating insulation is properly installed.
- g) Grounding wires are properly connected.
- h) Length of the piping and additional refrigerant stow capacity have been recorded.
- i) Power voltage is the correct voltage for the air conditioner.

CAUTION

Failure to perform the test run may result in unit damage, property damage, or personal injury.

Test Run Checks

1. Open both the liquid and gas stop valves.
2. Turn on the main power switch and allow the unit to warm up.
3. Set the air conditioner to COOL mode.
4. For the Indoor Unit
 - a. Ensure the remote control and its buttons work properly.
 - b. Ensure the louvers move properly and can be changed using the remote control.
 - c. Double check to see if the room temperature is being registered correctly.
 - d. Ensure the indicators on the remote control and the display panel on the indoor unit work properly.
 - e. Ensure the manual buttons on the indoor unit works properly.

- f. Check to see that the drainage system is unimpeded and draining smoothly.
 - g. Ensure there is no vibration or abnormal noise during operation.
5. For the Outdoor Unit
 - a. Check to see if the refrigeration system is leaking.
 - b. Make sure there is no vibration or abnormal noise during operation.
 - c. Ensure the wind, noise, and water generated by the unit do not disturb your neighbors or pose a safety hazard.
 6. Drainage Test
 - a. Ensure the drainpipe flows smoothly. New buildings should perform this test before finishing the ceiling.
 - b. Remove the test cover. Add 2,000ml of water to the tank through the attached tube.
 - c. Turn on the main power switch and run the air conditioner in COOL mode.
 - d. Listen to the sound of the drain pump to see if it makes any unusual noises.
 - e. Check to see that the water is discharged. It may take up to one minute before the unit begins to drain depending on the drainpipe.
 - f. Make sure that there are no leaks in any of the piping.
 - g. Stop the air conditioner. Turn off the main power switch and reinstall the test cover.

NOTE: If the unit malfunctions or does not operate according to your expectations, please refer to the Troubleshooting section of the Operation Manual before calling customer service.

CHECK LIST

FINAL CHECKLIST



The checklist is **ONLY** to be completed by an **Authorised Person**.

Check Item	✓	What can happen if not checked
Is the indoor unit installed securely?	<input type="checkbox"/>	Falling, vibration, noise
Has an inspection been made to check for gas leakage?	<input type="checkbox"/>	No cooling or heating
Has all thermal insulation been completed (vapour pipes, liquid pipes, indoor portions of the drain hose extension)?	<input type="checkbox"/>	Condensation
Is the drainage secure?	<input type="checkbox"/>	Water leakage
Are the electric wires installed correctly?	<input type="checkbox"/>	No cooling or heating, may cause electrical shock or electrical fire.
Is the wiring in accordance within the specifications?	<input type="checkbox"/>	Operation failure, electrical fire
Are all inlets / outlets of the indoor and outdoor units free of any obstructions?	<input type="checkbox"/>	No cooling or heating
Are the stop valves open?	<input type="checkbox"/>	No cooling or heating
Are the pipes designed for use with R32?	<input type="checkbox"/>	Pipe or pipe connection leakage
Has a leak test been carried out for the pipe connections?	<input type="checkbox"/>	Pipe connection leakage
Has air evacuation been carried out?	<input type="checkbox"/>	No cooling or heating
Has the appliance been tested for correct operation?	<input type="checkbox"/>	No cooling or heating
Is the end user fully aware of the operating procedure?	<input type="checkbox"/>	Incorrect operation

If you have answered no to any of the above, you must check and correct before appliance hand-over to customer.

WARRANTY

TERMS OF WARRANTY – AUSTRALIA

Rinnai Australia Pty. Ltd. ABN 74 005 138 769, 100 Atlantic Drive, Keysborough VIC 3173.

1 DEFINITIONS

The terms listed below shall have the following meanings:

- 1 **“Authorised Service Representative”** means an independent service contractor authorised by Rinnai or Rinnai service personnel.
- 2 **“Rinnai”** means Rinnai Australia Pty Ltd (ABN 74 005 138 769) and any related company.
- 3 **“Certificate(s) of Compliance”** means certificate(s) issued by licensed personnel (including plumbers, refrigeration mechanics, electricians or other relevant tradespeople) to certify that any prescribed works comply with applicable regulatory requirements.
- 4 **“Certificate(s) of Occupancy”** means certificate(s) issued by the local government authority (or similar organisation) which certifies that a home can be occupied.
- 5 **“Installation Site”** means the site at which the Product is originally installed.
- 6 **“Normal Business Hours”** means 8:30am to 5:00pm Monday to Friday, excluding public holidays.
- 7 **“Operating/Installation Instructions”** means the user manual or other documentation which provides detailed instructions on the proper operation and maintenance of the Product.
- 8 **“Other Applications”** means any Product used for purposes other than Residential & Light Commercial Applications. Other Applications may include but are not limited to factory, IT/Server room, telephone exchange, processing area (e.g. bakery, kitchen, warehouse, swimming pool, agricultural facilities such as a nursery). Any Product which has been installed, for whatever purpose, as a retrofit component to an existing system, will also be classed as being part of an “Other Application” regardless of the purpose of use of the existing system into which such product has been installed.
- 9 **“Purchaser”** means the end user of the Product, the person named as owner in the Warranty certificate, the holder of the Proof of Purchase or the holder of a property transfer document where the Product is included as part of the chattels.
- 10 **“Product”** means the equipment purchased by the Purchaser and described in Section 2 of this document.
- 11 **“Proof of Purchase”** means a Tax Invoice or Receipt in respect of the Product. In the case of new constructions, a Certificate of Occupancy or a Certificate of Compliance that details the date of installation or commissioning will suffice.
- 12 **“Qualified Installer”** means the qualified installation contractor who is responsible for performing the installation work in the manner prescribed by local and statutory regulations, including compliance with any relevant and to Rinnai specifications, including Australian Standards.
- 13 **“Residential & Light Commercial Applications”** means any Product for use in residential or light commercial applications where
 - a) the Product is solely used for the purpose of human comfort; and
 - b) the ambient temperature of the space the Product is intended to heat or cool is influenced solely or primarily by natural exterior weather conditions rather than by man-made or mechanical heat sources.

Examples of Residential & Light Commercial Applications include, homes, offices, hotels, apartments, nursing homes, hospitals, health care premises, shopping centres, and retail stores.

2 TERMS OF WARRANTY

- 2.1 Subject to the Terms of Warranty set out in this document, effective from the date of purchase by the Purchaser, the Product is warranted to be free from defects in materials & factory workmanship for the period set out in table below:

	PRODUCT GROUPS	PARTS	LABOUR
Residential and Light Commercial	Evaporative Coolers & Ducted Gas Heaters (excluding Compact Classic Series)	5 Years *Extended 4 Years Option	5 Years *Extended 4 Years Option
	Ducted Gas Heaters - Compact Classic Series	3 Years	3 Years
	Refrigerated Air conditioning Products	5 Years	5 Years
	Ducted Gas Heaters - Heat Exchangers and Burners Evaporative Coolers - Structural components only	10 Years	N/A
	Portable Air conditioning / Dehumidifier / Air Purifier	2 Years	N/A
	Electric Panel Heaters ⁽¹⁾	7 Years	N/A
	Outdoor Radiant Heater	3 Years	1 Year
	Electric Fire Heater	5 Years	5 Years
	Wi-Fi Devices	1 Year	1 Year
	Other Applications	All Product Groups	2 Years
After Market	Spare Parts	1 Year	N/A
*Extended Warranty Option	Up to 4 year extended warranty (in addition to the standard warranty period listed above) applies on selected products when you opt in to the Rinnai Service Advantage program. This program has terms and conditions, including the requirement for scheduled servicing of the product by Rinnai. To participate in the program you must register your product online at: www.rinnai.com.au/support-resources/warranty-registration/ within the first 12 months of the product being installed.		

⁽¹⁾ To make a claim under this warranty, please contact your place of purchase within the warranty period.

- 2.2 Rinnai will determine in its sole discretion, which classification the Product fits into and the corresponding Warranty that shall apply.
- 2.3 An Authorised Service Representative will repair or replace, at its option, the Product or any part of the Product that its examination shows to be defective. The repair or replacement shall be performed during Normal Business Hours by an Authorised Service Representative. Repair by persons other than an Authorised Service Representatives may void the Warranty.
- 2.4 Alternatively to clause 2.3 above, Rinnai can at its discretion elect to pay you an amount equivalent to the cost of repairing or replacing the Product.
- 2.5 If Rinnai provides you with either the replacement costs or replacement product, ownership of the original Product shall immediately transfer to Rinnai.
- 2.6 Rinnai is responsible for reasonable costs associated with legitimate warranty claims, including call-out of an Authorised Service Representative to inspect the Product. Rinnai is not responsible for:
- costs for tradespeople engaged by you that are not Rinnai Authorised Service Representatives.
 - any costs, including call out costs for a Rinnai Authorised Service Representatives, associated with a Product which is determined upon inspection not to be covered by this warranty.
- 2.7 Rinnai will reimburse any reasonable costs associated with making a legitimate warranty claim against Rinnai which are not otherwise specified above.
- 2.8 The Warranty of the Product requires that, in addition to all other conditions, the Purchaser conducts regular and/or preventative maintenance as may be specified by the Operating/Installation Instructions or otherwise directed by Rinnai and required by the level of usage and the usage environment, including the use of correct and uncontaminated refrigerants and lubricants. Refrigeration, plumbing and electrical works must be undertaken by licensed personnel.
- 2.9 Where a Product or failed component is replaced under warranty, the time remaining on the original Product warranty period will continue to apply and the replacement product or part will be subject to the original warranty period only.

3 CONDITIONS OF WARRANTY

- 3.1 The Purchaser may only obtain the benefit of the Warranty if the Purchaser:
- maintains and has the Product serviced in accordance with the instructions set out in the service section of the relevant Service or Owner's Manual;
 - complies with clause 7 "Purchaser's Responsibilities" on page 57;
 - notifies Rinnai within 30 days of a defect occurring or, in the case of a latent defect, becoming apparent, that a claim is being made under this Warranty; and
 - provides, in support of the claim made under this Warranty, a Proof of Purchase.
- 3.2 This document (and any statutory consumer guarantees) represents the only Warranty given by Rinnai in respect of the Product. No other person or organisation is authorised to offer any alternative warranty on behalf of Rinnai.
- 3.3 If the date of purchase cannot be established to Rinnai's satisfaction, the date shall be deemed to be 2 months after the date of manufacture or the date of sale by Rinnai, whichever is the latter.
- 3.4 This warranty applies to Products which are manufactured on or after the date of publication of this warranty but before the next date of publication of this warranty.

4 EXCLUSIONS

- 4.1 This Warranty **does NOT** cover:
- damage, problems or failure resulting from improper operation and/or inadequate maintenance by the Purchaser (refer Purchaser's Responsibilities section below);
 - damage, problems or failure resulting from improper or faulty installation. The Product must be installed by a Qualified Installer in accordance with applicable regulations. Where applicable, Certificate(s) of Compliance must be obtained by the purchaser from the Qualified Installer and presented to the Authorised Service Representative;
 - damage, problems or failure caused by factors external to the Product including, but not limited to, faulty or poor external electrical wiring, incorrect or faulty power supply, voltage fluctuations, over voltage transients or electromagnetic interference, inadequate or faulty gas, drainage services, or water services, including water pressure, and non-potable water;
 - damage, problems or failure caused by acts of God, fire, wind, lightning, flood, storm, hail storm fallout, vandalism, earthquake, war, civil insurrection, misuse, abuse, negligence, accident, pests, animals, pets, vermin, insects, spiders/bugs or entry of foreign objects or matter into the Product such as dirt, debris, soot or moisture;
 - damage, problems or failure caused by environmental conditions including, but not limited to, excessive moisture, salt or other corrosive substances or atmospheric conditions;
 - Product which has been installed in a portable or mobile building, structure or application including, but not limited to, a caravan, boat or trailer;
 - Product which has been re-installed at a location other than the original site;
 - any consumable item supplied with the Product including, but not limited to, an air filter, battery, fan belt, igniter or cooler pad;
 - installation of third-party components that may be attached to the Product. These include, but are not limited to, control wiring, ducting, return air filter(s) grille, register, diffuser, zone motors, controls/thermostats, pipe work and fabricated or added components. These items remain solely the responsibility of the Qualified Installer;
 - installations where electrics/electronics may be subjected to moisture/chemicals (e.g. swimming pools or nurseries);
 - any repair, which is needed as a result of an accident, misuse, abuse or negligence;
 - Product that is utilised in an environment (indoor and outdoor) outside its specified operating range; and
 - fair wear and tear to the Product.
 - On-site labour warranty on portable (non-fixed installation) Products – In respect of such Products the Purchaser must return the Product to the supplier for repair or replacement).

5 LIMITATIONS

- 5.1 Third parties are often involved in providing advice to consumers about the climate control solutions best suited to the consumer's needs. Any advice or recommendations given by such parties, including advice about Product fitness for purpose and overall system design, sizing and application are not the responsibility of Rinnai. This includes but is not limited to the heat load calculations, airflow and system balancing.
- 5.2 This Warranty does not apply to any Product installed at an Installation Site which is outside Australia.
- 5.3 Except where inconsistent with the purchaser's statutory rights and the rights given by this Warranty, all liabilities of Rinnai for any direct, special, indirect or consequential loss or damage, any damage or expense for personal injury or any loss or destruction of property, arising directly or indirectly from the use or inability to use the Product or any of its parts and/or servicing the Product, are expressly excluded.

6 TRAVEL, TRANSPORT & ACCESS COSTS

- 6.1 The Purchaser must pay freight charges, in-transit insurance expenses and travelling costs for repairs/replacements under this Warranty, that are required to be performed 50km from the nearest Rinnai branch or Authorised Service Representative.
- 6.2 Subject to clause 6.3, Rinnai will pay freight charges, in-transit insurance expenses and travelling costs for repairs/replacements that are required to be performed less than 50km from the nearest Rinnai branch or Authorised Service Representative, subject to the following:
- Rinnai will arrange for such repairs/replacements and make any payment directly to the third party to provide the freight, in-transit insurance or travel services; or
 - if Rinnai considers appropriate, it will authorise the Purchaser in writing to pay for the relevant freight charges, in-transit insurance expenses or travelling costs and then, upon provision by the Purchaser to Rinnai of a tax invoice showing those costs have been incurred, reimburse the Purchaser for such costs which are within the terms of the authorisation. If the Purchaser pays for the relevant freight charges, in-transit insurance expenses or travelling costs without written authorisation from Rinnai, Rinnai will not reimburse the Purchaser for such costs.
- 6.3 The Purchaser must pay all costs and expenses in respect of:
- any service call out fee if the Product is not accessible for service
 - making the Product accessible for service, for example, restricted access or working at heights, or the labour cost for an additional person due to OHS requirements.
 - providing a safe working environment for installation, service, maintenance or repair of the Product;
 - any surcharge applicable in respect of supplying replacement parts outside Normal Business Hours; and
 - any other costs and expenses in relation to claiming the Warranty that is not covered by clause 6.2.

7 PURCHASER'S RESPONSIBILITIES

- 7.1 The Purchaser must operate and maintain the Product in accordance with the Operating Instructions and service maintenance schedule, including conducting an appropriate number of services to the unit during the Warranty period, based on usage and the usage environment including but not limited to;
- regularly cleaning the air filter(s) and replacing them where necessary;
 - replacing expired batteries or other consumables as required;
 - ensuring that the condensate drain is kept clean and clear of obstructions.

HOW TO MAKE A WARRANTY CLAIM:

If you wish to make a warranty claim in respect of any Portable Product, please return it to the place of purchase, or if that is not possible, contact Rinnai to enquire about alternative arrangements.

If you wish to make a warranty claim in respect of any fixed Product, please contact Rinnai on the details set out below to make arrangements for an Authorised Service Representative to inspect the product.

As per clause 2.6 of the Terms and Conditions of Warranty, purchasers are responsible for the costs of any repair and/or call out fee where, on inspection, the alleged defect is found by Rinnai's Authorised Service Representative not to be covered by this warranty or any statutory consumer guarantee applicable to the Product.

The Terms and Conditions of Warranty contain important information about your rights and obligations under this warranty. Please read them fully and carefully before making a claim.

NOTICE TO CONSUMERS UNDER AUSTRALIAN CONSUMER LAW

Our goods and services come with guarantees that cannot be excluded under the Australian Consumer Law.

For a major failure with a good, you are entitled to a replacement or refund and compensation for any other reasonable foreseeable loss or damage. If the failure does not amount to a major failure and if the goods fail to be of acceptable quality, you are also entitled to have the goods repaired or replaced.

For a major failure with the service, you are entitled to cancel your service contract with us and obtain a refund for the unused portion, or to compensation for its reduced value. You are also entitled to be compensated for any other reasonably foreseeable loss or damage. If the failure does not amount to a major failure you are entitled to have problems with the service rectified in a reasonable time and, if this is not done, to cancel your contract and obtain a refund for the unused portion of the contract.

The benefits provided by this Warranty are in addition to any other rights and remedies available to a consumer under the Australian Consumer Law and any other law which may apply to the goods and or services.

NOTES



Rinnai Australia Pty Ltd

ABN 74 005 138 769 | AU45204

100 Atlantic Drive, Keysborough, Victoria 3173
P.O. Box 460, Braeside, Victoria 3195
Tel: (03) 9271 6625

National Help Line

Tel: 1300 555 545*

Monday to Friday, 8.00 am to 5.00 pm EST.

**Cost of a local call may be higher from a mobile phone.
(National calls from public phones in Australia are free.)*

For further information visit www.rinnai.com.au
or email enquiry@rinnai.com.au

Rinnai has a Service and Spare Parts network with personnel who are fully trained and equipped to give the best service on your Rinnai appliance. If your appliance requires service, please call our National Help Line. Rinnai recommends that this appliance be serviced once a year.

With our policy of continuous improvement, we reserve the right to change, or discontinue at any time, specifications or designs without notice.