

Rinnai



Demand Duo
Specification Guide

What is a Demand Duo?



A Rinnai Demand Duo is a combination of Heavy Duty Continuous Flow Water Heaters that maintain the temperature in a heavily insulated storage tank. The storage tank acts as a hydraulic separator between the primary and secondary loop of the Hot Water System whilst balancing the pressure between the cold and hot water.

Demand Duos are designed and made in Australia (HD water heaters manufactured in Japan) and backed by Rinnai's global commitment to quality.

How does it work?

As a complete packaged storage hot water system a Demand Duo is made up of one or more HD water heaters ManifolDED in parallel, primary pump(s), controller and a storage tank.

The inbuilt controller detects the temperature of the water in the tank and when it drops below the set value, the primary pump is activated. This flow in turn activates the Continuous Flow HD Water Heater(s) which returns heated water to the tank.

Packages are available in standard customisable form or as a complete engineered system mounted on a skid base. Both are supplied in modular form for ease of installation and transport. In a Single Lift scenario it will not be transported in modular form.

What are the key benefits?

- A short period of high hot water flow rate
- Various Heavy Duty Continuous Flow heater options available
- 444 Stainless Steel Storage Tanks with 250L and 315L storage volumes
- Vitreous Enamel coated tanks with 270L, 330L and 440L storage volumes
- Large plumbing connections on storage tanks to cater for high flow rates
- Heat source can be located away from the tank to suit installation requirements per project
- Modular construction for ease of installation and transport
- Perfect for projects with a limited gas supply
- External or internal units available
- A single HD water heater Demand Duo (DD1) is a stand-alone appliance for ease of installation which is perfect for quick replacements
- Single Lift option of the heat source, primary pump(s) and controller(s) for fast site installation
- Dual Primary Pump(s) and Control System(s) available in back to back systems
- Innovative controller with push button interface and LCD display

What are suitable applications?

- Hotels and Motels
- Apartment Blocks
- Student Accommodation
- Variety of other applications where a quick recovery rate is required
- Shower Blocks
- Commercial Kitchens
- Commercial Laundries

Heart of the system

Our Heavy Duty Continuous Flow range of water heaters are specifically designed for commercial use with inbuilt intelligence and durability to stand the test of time in the harshest of commercial environments. With various efficiency and flow rate options available Rinnai can provide the perfect solution based on your application, whether internally or externally mounted. Generally, projects with very high energy costs would benefit from the use of our HD210 higher efficiency condensing technology as the increased capital expenditure is absorbed by the annual energy cost savings.

Heavy Duty Non Condensing (83% Thermal Efficiency)



Heavy Duty Condensing (97% Thermal Efficiency)



Demand Duo Standard Options

How are standard packages supplied?

Demand Duo is available in a wide variety of options to suit your budget. These various forms offer installation flexibility or a complete package resulting in no plumbing or installation work being required. From an integrated Demand Duo with one heater to multiple tanks with multiple heaters there is a solution that can easily be selected to streamline your project.

Integrated Demand Duo 1 gas storage option

Replacement of an existing gas storage heater is made simple with our Demand Duo 1 unit. Lightweight yet robust construction allows for easy transportation into those hard to get to places while offering many years of consistent hot water. Your choice of HD water heater can be integrated with either a vitreous enamel or Stainless steel storage tank offering flexibility of choice to suit all applications and water quality restrictions. The smallest unit available using a Stainless Steel 250L tank and HD28 weighs in at approximately 100 kgs.



Demand Duo using multiple HD's

If your project has a large hot water demand where high peak flow rates are expected then selecting a Demand Duo with multiple water heaters is ideal. A modular system using one or more storage tanks will cater for this hot water load. Installation is made easy with our three options under the Demand Duo range available – whether it's a retrofit project or a complete package you're looking for we have the solution.

Demand Duo

The tried and tested Demand Duo, that has widely become accepted as the go-to product for centralised hot water systems, is supplied in a modular form being split into 3 major components.

1. Storage Tank(s)
2. Primary activation pump(s) and required fittings
3. Heat source (using the HD water heaters of your choice) with integrated intelligent controller

The heat source is bundled in modules for ease of transportation to the installation site which is ideal for those upgrade projects to replace existing outdated hot water plants.

When working in a tight space, particularly an internal plant room, the flexibility of this Demand Duo system will allow a solution to be designed that could even be installed in stages to minimise interruption to hot water supply.

Demand Duo Plus

As a relatively new addition to the range the Demand Duo Plus is also supplied in modules but in a slightly different format being split into 2 major components reducing on-site installation time.

1. Storage Tank(s)
2. Heat source (using the HD Water Heaters of your choice) with integrated intelligent controller and primary activation pump

The heat source is also bundled in modules for ease of transportation but with additional features to save valuable assembly time. The primary activation pump(s) is pre-mounted and appropriately plumbed, including insulation, with the added inclusion of electrical GPO's for the water heaters and the intelligent controller.

Demand Duo Pro

The Demand Duo Pro is the ultimate hot water package that removes all the worry of assembling modules on site effectively removing all on-site installation time. It is uniquely designed to be sited in position with minimal fuss as all plumbing, insulation and electrical work is provided.

The complete package is engineered to suit your project requirements and mounted on a suitably robust skid base. All you need to do is connect your pipework, plug it in to an electrical outlet and away you go!

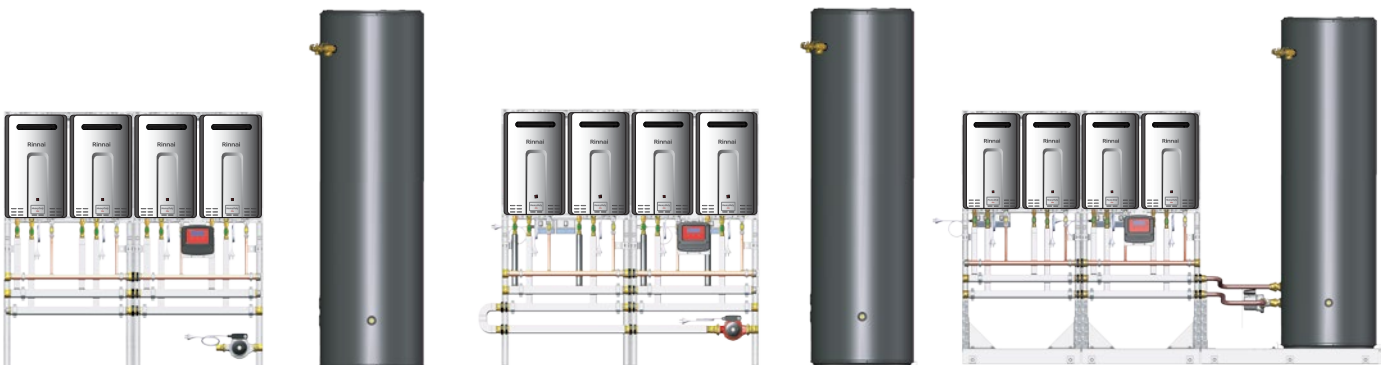

Solutions and Accessories

Rinnai can offer a customised solution with a high focus on your core deliverables. The aesthetic appearance of developments is paramount. We can tailor solutions to suit your business, bespoke systems can be constructed to suit specific requirements including (but not limited to) lower frame size, precise wall mounting application or different size pipework. Rinnai's Commercial Hot Water Solutions match minimum height requirements, are modular and compact, and can be easily integrated into the building, with easy access for future serviceability. To compliment this, we have an extensive range of accessories.

Accessories

- 315L Horizontal Storage Tank with 32mm plumbing connections
- Single circulation pumps for reticulation systems
- Dual circulation pumps for reticulation systems with intelligent controller packed with features
- Building Management System (BMS) integration
- Common flueing for internal installations
- Centralised Warm Water Management Valve
- Legionella control devices
- Heat exchange systems offering flexibility in design of pressure zones or water quality management
- Remote monitoring systems to manage your hot water plants from anywhere at anytime
- Non-modular packages with engineered frame and lifting points for easy hoisting and placement on site

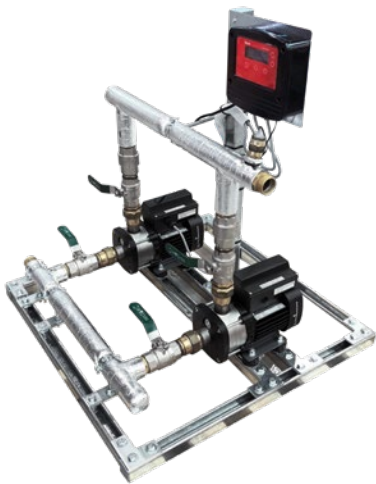

Large Pumpset



Pump Plate



Heat Exchange Systems



Horizontal Tank



Large MP Lifting with engineered frame



◀ Tradewinds Cairns | QLD Riley Crystalbrook Resort

Crystalbrook Collection embarked on developing its first five-star hotel, Riley, A Crystalbrook Collection Resort. Located at the northern end of Cairns iconic waterfront Esplanade, the resort features 311 rooms and suites, three restaurants and bars, an expansive lagoon pool and private beach, the Eléme Day Spa and much more.

Rinnai provided two Demand Duo Systems using high efficiency condensing Heavy Duty Water Heaters split over 2 plants. One of which was specifically designed on a low frame to suit the stringent design constraints.

▶ Skye Suites | NSW

A striking new 25-storey high rise, with 73 suites for guests it was designed by the Tokyo-born Sydney architect Koichi Takada. At street level, Arc presents as a handsome 19th-century warehouse, its red-brick columns holding up elegant arches. Twin towers above are topped with arched ribs that look from a distance like white armadillo shells.

Rinnai provided a complex mixture of four Demand Duo systems using Heavy Duty Water Heaters. Common flue was a key feature to minimise the aesthetic impact on the building's exterior which is often the case with multiple flue terminals.



◀ City West Police Complex | VIC

In a prime location on Spencer Street in Melbourne's CBD the brief for this brand new state of the art police station was quite specific – construct to exacting security standards but with a 5 star green energy rating.

The internal hot water plant was very specific with two sources of preheated water (to save on fuel costs) and a maximum allowable water temperature to be circulated around the building. Using our Warm Water valve as the basis Rinnai was able to design and construct a complex safety and preheat blending valve system.

Selecting a Demand Duo System

What information do I need?

The following information is required to select a Demand Duo System:

- Delivery temperature required. The available temperatures are 65°C - 82°C in 1°C increments
- Volume of hot water used per event (i.e. people having a shower)
- Number of times this event occurs (i.e. 6 uses of each shower head per hour)
- Internal or external installation (i.e. whether a flue system is required)

A Demand Duo is selected based on the volume of water used per event multiplied by the number of events that occur. This is calculated over a set period of time which is usually one hour.

With our predetermined sizing criteria its never been easier to determine the first hour hot water demand and select the appropriate system.

Apartments

- 1 bedroom unit = 45 litres in the first hour
- 2 bedroom unit = 75 litres in the first hour
- 3 bedroom unit = 105 litres in the first hour

Amenities

Each shower outlet = 27 litres per shower with a maximum of 6 showers per hour

Note: For constant usage showers (sporting clubs as an example) a Rinnai Manifold Pack would be a better option.

Hotel

1 bed in a 1-3 star Hotel = 22 litres in the first hour

1 bed in a 4-5 star Hotel = 35 litres in the first hour

Note: This allows for showers, meals and laundry

Example:

An apartment block in Melbourne consisting of 40 apartments with 2 bedrooms and 10 apartments with 1 bedroom requires hot water at a delivery temperature of 65°C:

1. Calculate the hot water demand for the 2 bedroom apartments = 40×75 litres = 3000 litres
2. Calculate the hot water demand for the 1 bedroom apartments = 10×45 litres = 450 litres
3. Once you have arrived at the total first hour requirement, 3450 litres in this instance you can select your system
4. Determine which HD heat source you wish to employ and refer to the tables below to select a system. Using a HD28 external in this example the resulting selection is DD4 28 250



Non condensing HD28 external/internal							
Apartments	Apartments	Hotel	Amenities	First Hour	Recovery Rate	Model	Gas Rate MJ/H
No. of 2 Bedrooms	No. of 2&3 Bedrooms	No. of Beds (3 Star)	No. of Showers	Litres/Hour (50°C rise)	Litres/Hour (50° C rise)		
15	12	50	7	1110	835	DD128 250/270	210
16	13	53	7	1170	835	DD128 315/330	210
26	22	88	12	1940	1670	DD 2 28 250/270	420
27	22	91	12	2000	1670	DD 2 28 315/330	420
28	23	96	13	2110	1670	DD 2 28 440	420
37	31	126	17	2775	2505	DD 3 28 250/270	630
38	32	129	18	2835	2505	DD 3 28 315/330	630
39	33	134	18	2945	2505	DD 3 28 440	630
48	40	164	22	3610	3340	DD 4 28 250/270	840
49	41	167	23	3670	3340	DD 4 28 315/330	840
50	42	172	23	3780	3340	DD 4 28 440	840
59	49	202	27	4445	4175	DD 5 28 250/270	1050
60	50	205	28	4505	4175	DD 5 28 315/330	1050
62	51	210	28	4615	4175	DD 5 28 440	1050
70	59	240	33	5280	5010	DD 6 28 250/270	1260
71	59	243	33	5340	5010	DD 6 28 315/330	1260
73	61	248	34	5450	5010	DD 6 28 440	1260
82	68	278	38	6115	5845	DD 7 28 250/270	1470
82	69	281	38	6175	5845	DD 7 28 315/330	1470
84	70	286	39	6285	5845	DD 7 28 440	1470
96	80	328	45	7220	6680	DD 8 28 500/540	1680
98	82	334	45	7340	6680	DD 8 28 630/660	1680
101	84	344	47	7560	6680	DD 8 28 880	1680
107	90	366	50	8055	7515	DD 9 28 500/540	1890
109	91	372	50	8175	7515	DD 9 28 630/660	1890
112	93	382	52	8395	7515	DD 9 28 880	1890
119	99	404	55	8890	8350	DD 10 28 500/540	2100
120	100	410	56	9010	8350	DD 10 28 630/660	2100
123	103	420	57	9230	8350	DD 10 28 880	2100

Output calculated on an incoming water temperature of 15°C.

Non condensing HD32 external							
Apartments	Apartments	Hotel	Amenities	First Hour	Recovery Rate	Model	Gas Rate MJ/H
No. of 2 Bedrooms	No. of 2&3 Bedrooms	No.of Beds (3 Star)	No. of Showers	Litres/Hour (50°C rise)	Litres/Hour (50 °C rise)		
17	14	59	8	1290	1015	DD 132E 250	250
18	15	61	8	1350	1015	DD 132E 315	250
31	26	105	14	2300	2030	DD 2 32E 250/270	500
31	26	107	15	2360	2030	DD 2 32E 315/330	500
33	27	112	15	2470	2030	DD 2 32E 440	500
44	37	151	20	3320	3050	DD 3 32E 250/270	750
45	38	154	21	3380	3050	DD 3 32E 315/330	750
47	39	159	22	3490	3050	DD 3 32E 440	750
58	48	197	27	4335	4065	DD 4 32E 250/270	1000
59	49	200	27	4395	4065	DD 4 32E 315/330	1000
60	50	205	28	4505	4065	DD 4 32E 440	1000
71	60	243	33	5355	5085	DD 5 32E 250/270	1250
72	60	246	33	5415	5085	DD 5 32E 315/330	1250
74	61	251	34	5525	5085	DD 5 32E 440	1250
85	71	290	39	6370	6100	DD 6 32E 250/270	1500
86	71	292	40	6430	6100	DD 6 32E 315/330	1500
87	73	297	40	6540	6100	DD 6 32E 440	1500
99	82	336	46	7390	7120	DD 7 32E 250/270	1750
99	83	339	46	7450	7120	DD 7 32E 315/330	1750
101	84	344	47	7560	7120	DD 7 32E 440	1750
116	96	394	54	8675	8135	DD 8 32E 500/540	2000
117	98	400	54	8795	8135	DD 8 32E 630/660	2000
120	100	410	56	9015	8135	DD 8 32E 880	2000
129	108	441	60	9695	9155	DD 9 32E 500/540	2250
131	109	446	61	9815	9155	DD 9 32E 630/660	2250
134	112	456	62	10035	9155	DD 9 32E 880	2250
143	119	487	66	10710	10170	DD 10 32E 500/540	2500
144	120	492	67	10830	10170	DD 10 32E 630/660	2500
147	123	502	68	11050	10170	DD 10 32E 880	2500

Condensing HD210 external/internal							
Apartments	Apartments	Hotel	Amenities	First Hour	Recovery Rate	Model	Gas Rate MJ/H
No. of 2 Bedrooms	No. of 2&3 Bedrooms	No.of Beds (3 Star)	No. of Showers	Litres/Hour (50°C rise)	Litres/Hour (50 °C rise)		
16	14	56	8	1225	955	DD 1210 250	210
17	14	59	8	1290	955	DD 1210 315	210
29	24	99	13	2180	1910	DD 2 210 250/270	420
30	25	102	14	2240	1910	DD 2 210 315/330	420
31	26	107	15	2350	1910	DD 2 210 440	420
42	35	143	19	3140	2870	DD 3 210 250/270	630
43	36	145	20	3200	2870	DD 3 210 315/330	630
44	37	150	20	3310	2870	DD 3 210 440	630
55	46	186	25	4095	3825	DD 4 210 250/270	840
55	46	189	26	4155	3825	DD 4 210 315/330	840
57	47	194	26	4265	3825	DD 4 210 440	840
67	56	230	31	5055	4785	DD 5 210 250/270	1050
68	57	233	32	5115	4785	DD 5 210 315/330	1050
70	58	238	32	5225	4785	DD 5 210 440	1050
80	67	273	37	6010	5740	DD 6 210 250/270	1260
81	67	276	37	6070	5740	DD 6 210 315/330	1260
82	69	281	38	6180	5740	DD 6 210 440	1260
93	77	317	43	6970	6700	DD 7 210 250/270	1470
94	78	320	43	7030	6700	DD 7 210 315/330	1470
95	79	325	44	7140	6700	DD 7 210 440	1470
109	91	373	51	8195	7655	DD 8 210 500/540	1680
111	92	378	51	8315	7655	DD 8 210 630/660	1680
114	95	388	53	8535	7655	DD 8 210 880	1680
122	102	416	57	9155	8615	DD 9 210 500/540	1890
124	103	422	57	9275	8615	DD 9 210 630/660	1890
127	106	432	59	9495	8615	DD 9 210 880	1890
135	112	460	62	10110	9570	DD 10 210 500/540	2100
136	114	465	63	10230	9570	DD 10 210 630/660	2100
139	116	475	65	10450	9570	DD 10 210 880	2100



Specifications

Stainless Steel Tanks

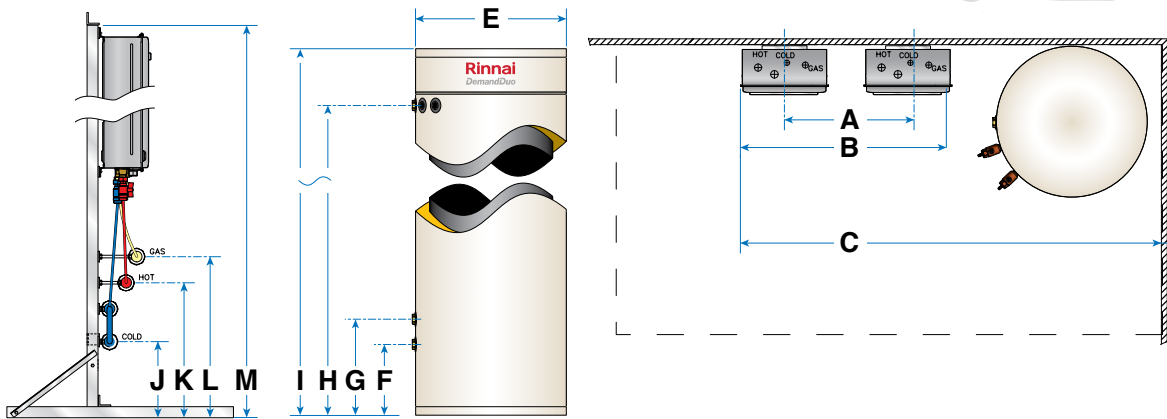
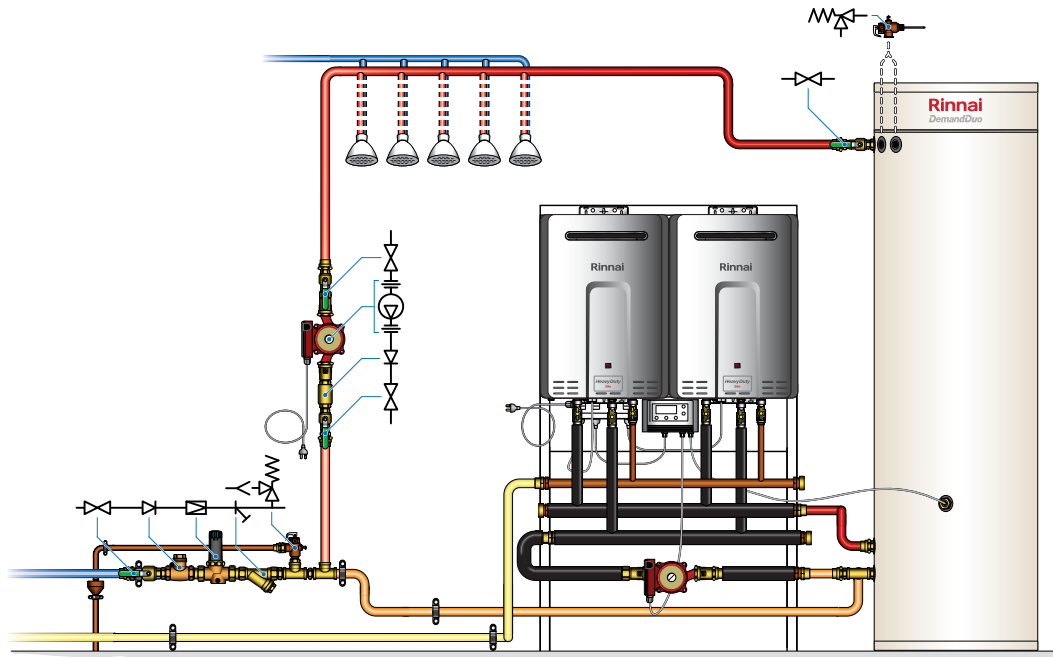

HD28 External/Internal Demand Duo																						
Model	A	B	C	E	F	G	H	I	J	K	L	M	Dry Weight	No. Of Tanks								
DD2 28 250	375	750	1600	600	285	385	1465	1690	260	440	540	1500	120 Kg	1								
DD2 28 315							1855	2080					132 Kg	1								
DD3 28 250		1125	1925				1465	1690					150 Kg	1								
DD3 28 315							1855	2080					162 Kg	1								
DD4 28 250		1500	2350				1465	1690					180 Kg	1								
DD4 28 315							1855	2080					192 Kg	1								
DD5 28 250		1875	2725				1465	1690					210 Kg	1								
DD5 28 315							1855	2080					222 Kg	1								
DD6 28 250		2250	3100				1465	1690					240 Kg	1								
DD6 28 315							1855	2080					252 Kg	1								
DD7 28 250		375	2625				3475	600					285	385	1465	1690	260	440	540	1500	270 Kg	1
DD7 28 315															1855	2080					282 Kg	1
DD8 28 500			3000				4700								1465	1690					370 Kg	2
DD8 28 630															1855	2080					394 Kg	2
DD9 28 500			3375				5075								1465	1690					400 Kg	2
DD9 28 630															1855	2080					424 Kg	2
DD10 28 500			3750				5450								1465	1690					430 Kg	2
DD10 28 630															1855	2080					454 Kg	2
DD11 28 500			4125				5825								1465	1690					460 Kg	2
DD11 28 630															1855	2080					484 Kg	2
DD12 28 500	4500		6200	1465	1690	490 Kg	2															
DD12 28 630				1855	2080	514 Kg	2															

All dimensions current at time of going to print. Rinnai reserves the right to make changes in-line with product improvements

HD32 External Demand Duo																						
Model	A	B	C	E	F	G	H	I	J	K	L	M	Dry Weight	No. Of Tanks								
DD2 32E 250	500	1000	1850	600	285	385	1465	1690	260	440	540	1500	131 Kg	1								
DD2 32E 315							1855	2080					143 Kg	1								
DD3 32E 32E		1500	2350				1465	1690					165 Kg	1								
DD3 32E 315							1855	2080					177 Kg	1								
DD4 32E 32E		2000	2850				1465	1690					204 Kg	1								
DD4 32E 315							1855	2080					216 Kg	1								
DD5 32E 32E		2500	3350				1465	1690					238 Kg	1								
DD5 32E 315							1855	2080					250 Kg	1								
DD6 32E 32E		3000	3850				1465	1690					272 Kg	1								
DD6 32E 315							1855	2080					284 Kg	1								
DD7 32E 32E		500	3500				4350	600					285	385	1465	1690	260	440	540	1500	306 Kg	1
DD7 32E 315															1855	2080					318 Kg	1
DD8 32E 500			4000				5700								1465	1690					402 Kg	2
DD8 32E 630															1855	2080					426 Kg	2
DD9 32E 500			4500				6200								1465	1690					436 Kg	2
DD9 32E 630															1855	2080					460 Kg	2
DD10 32E 500			5000				6700								1465	1690					470 Kg	2
DD10 32E 630															1855	2080					494 Kg	2
DD11 32E 500			5500				7200								1465	1690					504 Kg	2
DD11 32E 630															1855	2080					528 Kg	2
DD12 32E 500	6000		7700	1465	1690	538 Kg	2															
DD12 32E 630				1855	2080	562 Kg	2															

HD210 External/Internal Demand Duo																						
Model	A	B	C	E	F	G	H	I	J	K	L	M	Dry Weight	No. Of Tanks								
DD2 210 250	500	1000	1850	600	285	385	1465	1690	260	440	540	1500	160 Kg	1								
DD2 210 315							1855	2080					172 Kg	1								
DD3 210 250		1500	2350				1465	1690					205 Kg	1								
DD3 210 315							1855	2080					217 Kg	1								
DD4 210 250		2000	2850				1465	1690					250 Kg	1								
DD4 210 315							1855	2080					262 Kg	1								
DD5 210 250		2500	3350				1465	1690					295 Kg	1								
DD5 210 315							1855	2080					307 Kg	1								
DD6 210 250		3000	3850				1465	1690					340 Kg	1								
DD6 210 315							1855	2080					352 Kg	1								
DD7 210 250		500	3500				4350	600					285	385	1465	1690	260	440	540	1500	385 Kg	1
DD7 210 315															1855	2080					397 Kg	1
DD8 210 500			4000				5700								1465	1690					490 Kg	2
DD8 210 630															1855	2080					514 Kg	2
DD9 210 500			4500				6200								1465	1690					535 Kg	2
DD9 210 630															1855	2080					559 Kg	2
DD10 210 500			5000				6700								1465	1690					580 Kg	2
DD10 210 630															1855	2080					604 Kg	2
DD11 210 500			5500				7200								1465	1690					625 Kg	2
DD11 210 630															1855	2080					649 Kg	2
DD12 210 500	6000		7700	1465	1690	670 Kg	2															
DD12 210 630				1855	2080	694 Kg	2															

All dimensions current at time of going to print. Rinnai reserves the right to make changes in-line with product improvements



Specifications

Vitreous Enamel Tanks

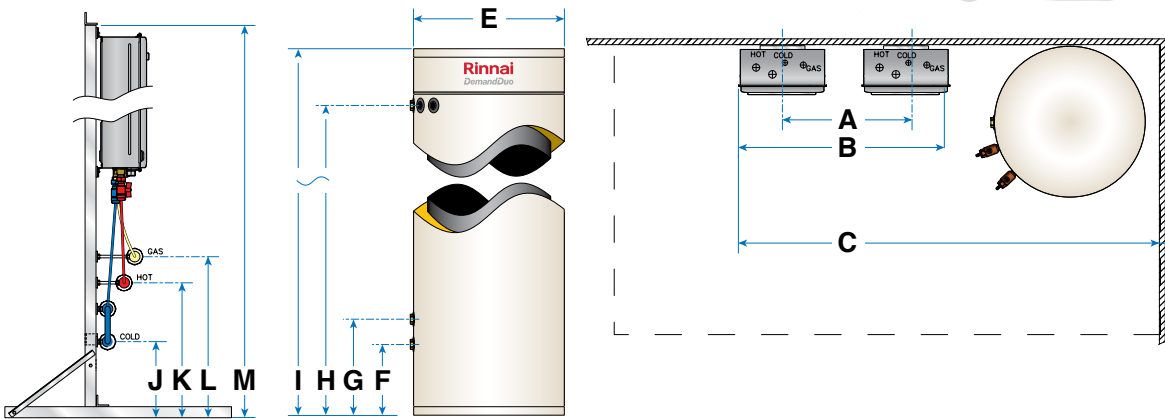
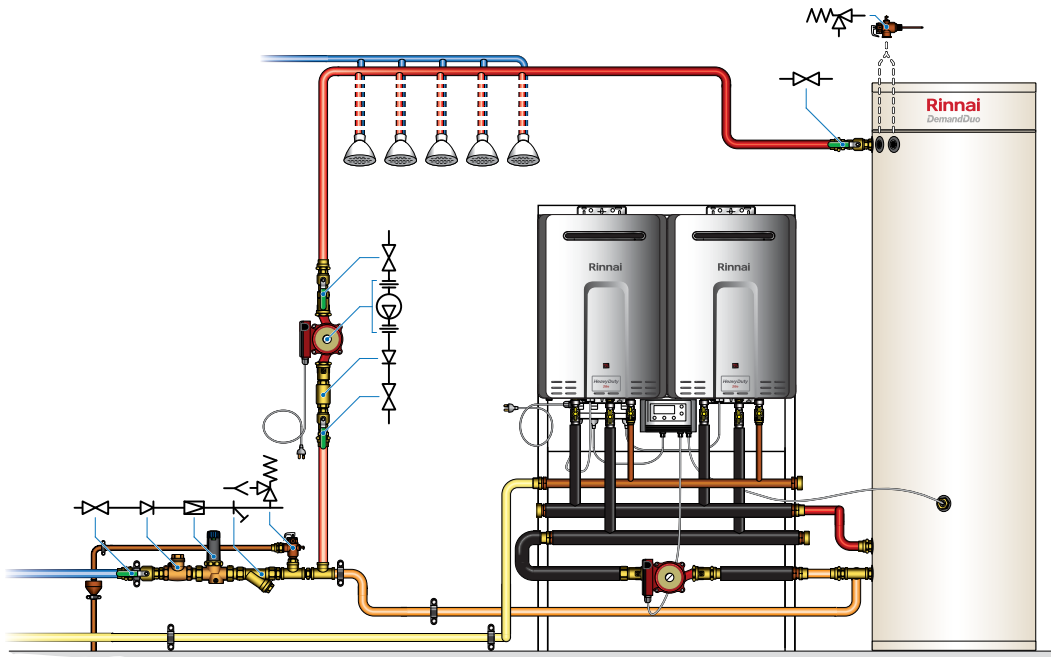

HD28 External/Internal Demand Duo														
Model	A	B	C	E	F	G	H	I	J	K	L	M	Dry Weight	No. Of Tanks
DD2 28 270	375	750	1625	625	108	286	1143	1484	260	440	540	1500	144 Kg	1
DD2 28 330							1431	1772					158 Kg	1
DD2 28 440							1720	720					1409	1763
DD3 28 270		1125	1950	625			1143	1484					174 Kg	1
DD3 28 330							1431	1772					188 Kg	1
DD3 28 440							2045	720					1409	1763
DD4 28 270		1500	2375	625			1143	1484					204 Kg	1
DD4 28 330							1431	1772					218 Kg	1
DD4 28 440							2470	720					1409	1763
DD5 28 270		1875	2750	625			1143	1484					234 Kg	1
DD5 28 330							1431	1772					248 Kg	1
DD5 28 440							2845	720					1409	1763
DD6 28 270		2250	3125	625			1143	1484					264 Kg	1
DD6 28 330							1431	1772					278 Kg	1
DD6 28 440							3220	720					1409	1763
DD7 28 270		2625	3500	625			1143	1484					294 Kg	1
DD7 28 330							1431	1772					308 Kg	1
DD7 28 440							3595	720					1409	1763
DD8 28 540		3000	4750	625			1143	1484					418 Kg	2
DD8 28 660							1431	1772					446 Kg	2
DD8 28 880							4940	720					1409	1763
DD8 28 540		3000	4750	625			1143	1484					418 Kg	2
DD8 28 660							1431	1772					446 Kg	2
DD8 28 880							4940	720					1409	1763
DD9 28 540		3375	5125	625			1143	1484					448 Kg	2
DD9 28 660							1431	1772					476 Kg	2
DD9 28 880							5315	720					1409	1763
DD10 28 540		3750	5500	625			1143	1484					478 Kg	2
DD10 28 660							1431	1772					506 Kg	2
DD10 28 880							5690	720					1409	1763
DD11 28 540	4125	5875	625	1143	1484	508 Kg	2							
DD11 28 660				1431	1772	536 Kg	2							
DD11 28 880				6065	720	1409	1763	584 Kg	2					
DD12 28 540	4500	6250	625	1143	1484	538 Kg	2							
DD12 28 660				1431	1772	566 Kg	2							
DD12 28 880				6440	720	1409	1763	614 Kg	2					

HD210 External/Internal Demand Duo														
Model	A	B	C	E	F	G	H	I	J	K	L	M	Dry Weight	No. Of Tanks
DD2 210 270		1000	1875	625		286	1143	1484	260	440	540	1500	184 Kg	1
DD2 210 330			1970	720			1431	1772					198 Kg	1
DD2 210 440			2375	625			1409	1763					222 Kg	1
DD3 210 270		1500	2375	625			1143	1484					229 Kg	1
DD3 210 330			2470	720			1431	1772					243 Kg	1
DD3 210 440			1409	1763	267 Kg		1							
DD4 210 270		2000	2875	625			1143	1484					274 Kg	1
DD4 210 330			2970	720			1431	1772					288 Kg	1
DD4 210 440			1409	1763	312 Kg		1							
DD5 210 270		2500	3375	625			1143	1484					319 Kg	1
DD5 210 330			3470	720			1431	1772					333 Kg	1
DD5 210 440			1409	1763	357 Kg		1							
DD6 210 270		3000	3875	625			1143	1484					364 Kg	1
DD6 210 330			3970	720			1431	1772					378 Kg	1
DD6 210 440			1409	1763	402 Kg		1							
DD7 210 270		3500	4375	625	108		1143	1484					409 Kg	1
DD7 210 330	500		4470	720			1431	1772					423 Kg	1
DD7 210 440			1409	1763	447 Kg		1							
DD8 210 540		4000	5750	625			1143	1484					538 Kg	2
DD8 210 660			5990	720			1431	1772					566 Kg	2
DD8 210 880			1409	1763	614 Kg		2							
DD9 210 540		4500	6250	625			1143	1484					583 Kg	2
DD9 210 660			6440	720			1431	1772					611 Kg	2
DD9 210 880			1409	1763	659 Kg		2							
DD10 210 540		5000	6750	625			1143	1484					628 Kg	2
DD10 210 660			6940	720			1431	1772					656 Kg	2
DD10 210 880			1409	1763	704 Kg		2							
DD11 210 540		5500	7250	625			1143	1484					673 Kg	2
DD11 210 660			7440	720			1431	1772					701 Kg	2
DD11 210 880			1409	1763	749 Kg		2							
DD12 210 540		6000	7750	625		1143	1484	718 Kg	2					
DD12 210 660			7940	720		1431	1772	746 Kg	2					
DD12 210 880			1409	1763	794 Kg	2								

All dimensions current at time of going to print. Rinnai reserves the right to make changes in-line with product improvements

HD32 External Demand Duo														
Model	A	B	C	E	F	G	H	I	J	K	L	M	Dry Weight	No. Of Tanks
DD2 32 270		1000	1875	625		286	1143	1484	260	440	540	1500	155 Kg	1
DD2 32 330			1970	720			1431	1772					169 Kg	1
DD2 32 440							1409	1763					193 Kg	1
DD3 32 270		1500	2375	625			1143	1484					189 Kg	1
DD3 32 330			2470	720			1431	1772					203 Kg	1
DD3 32 440							1409	1763					227 Kg	1
DD4 32 270		2000	2875	625			1143	1484					228 Kg	1
DD4 32 330			2970	720			1431	1772					242 Kg	1
DD4 32 440							1409	1763					266 Kg	1
DD5 32 270		2500	3375	625			1143	1484					262 Kg	1
DD5 32 330			3470	720			1431	1772					274 Kg	1
DD5 32 440							1409	1763					300 Kg	1
DD6 32 270		3000	3875	625			1143	1484					296 Kg	1
DD6 32 330			3970	720			1431	1772					310 Kg	1
DD6 32 440							1409	1763					334 Kg	1
DD7 32 270		3500	4375	625			1143	1484					330 Kg	1
DD7 32 330	500		4470	720	108		1431	1772					344 Kg	1
DD7 32 440							1409	1763					368 Kg	1
DD8 32 540		4000	5750	625			1143	1484					450 Kg	2
DD8 32 660			5990	720			1431	1772					478 Kg	2
DD8 32 880							1409	1763					526 Kg	2
DD9 32 540		4500	6250	625			1143	1484					484 Kg	2
DD9 32 660			6440	720			1431	1772					512 Kg	2
DD9 32 880							1409	1763					560 Kg	2
DD10 32 540		5000	6750	625			1143	1484					518 Kg	2
DD10 32 660			6940	720			1431	1772					546 Kg	2
DD10 32 880							1409	1763					594 Kg	2
DD11 32 540		5500	7250	625			1143	1484					552 Kg	2
DD11 32 660			7440	720			1431	1772					580 Kg	2
DD11 32 880							1409	1763					628 Kg	2
DD12 32 540		6000	7750	625		1143	1484	586 Kg	2					
DD12 32 660			7940	720		1431	1772	614 Kg	2					
DD12 32 880						1409	1763	662 Kg	2					

All dimensions current at time of going to print. Rinnai reserves the right to make changes in-line with product improvements

Warranty Info

Warranty	Domestic Use	Commercial Use
Heavy Duty Continuous Flow	12 Years (heat exchanger)	5 Years (heat exchanger)
Storage Cylinder	10 Years	5 years (VE) / 7 years (SS)
Common flue	N/A	3 Years

Rinnai Australia Pty Ltd

ABN 74 005 138 769

100 Atlantic Drive,
Keysborough, Victoria 3173

For further information
call 1300 555 545 or visit
rinnai.com.au

TOTAL HOME COMFORT



HOT WATER



HEATING



COOLING

Rinnai