













# LS Series | Specification Guide



**Rinnai**

# LS 800F Gas Fire



-  5 Star Efficiency
-  Flametech™
-  Double-sided
-  Single-sided
-  2 Speed Fan
-  Preheat Function
-  Wi-Fi
-  Air Filter
-  Logset
-  Overheat Safety
-  Indoor-Outdoor
-  Made in NZ

## Dimensions

	Height (mm)	Width (mm)	Depth (mm)	Outer Flue Diameter (mm)	Inner Flue Diameter (mm)
Appliance dimension	970	1245	435	75	50
Glass dimension	505	800		N/A	

## Technical Information

Gas Input MJ/h Low	Gas Input MJ/h High	kW Output	Gas Type
14	35	8.3	NG & LPG

## Room Sizing

Heats upto Capacity (m2)			
Very Cold	Cold	Cool	Mild
70	83	112	128

- 10 Year Heat Exchanger Warranty
- 2 Year Parts and Labour Warranty

# LS 1000F Gas Fire



5 Star Efficiency



Flametech™



Double-sided



Single-sided



2 Speed Fan



Preheat Function



Wi-Fi



Air Filter



Logset



Overheat Safety



Indoor-Outdoor



Made in NZ

## Dimensions

	Height (mm)	Width (mm)	Depth (mm)	Outer Flue Diameter (mm)	Inner Flue Diameter (mm)
Appliance dimension	745	1435	435	75	50
Glass dimension	280	1000		N/A	

## Technical Information

Gas Input MJ/h Low	Gas Input MJ/h High	kW Output	Gas Type
14	35	8.3	NG & LPG













## Room Sizing

Heats upto Capacity (m2)			
Very Cold	Cold	Cool	Mild
70	83	112	128

- 10 Year Heat Exchanger Warranty
- 2 Year Parts and Labour Warranty

# LS 1000 Gas Fire



-  5 Star Efficiency
-  Burn Media
-  Double-sided
-  Single-sided
-  2 Speed Fan
-  Preheat Function
-  Wi-Fi
-  Air Filter
-  Logset
-  Overheat Safety
-  Indoor-Outdoor
-  Made in NZ

## Dimensions

	Height (mm)	Width (mm)	Depth (mm)	Outer Flue Diameter (mm)	Inner Flue Diameter (mm)
Appliance dimension	745	1435	435	75	50
Glass dimension	280	1000		N/A	

## Technical Information

Gas Input MJ/h Low	Gas Input MJ/h High	kW Output	Gas Type
14	35	8.0	NG & LPG

## Room Sizing

Heats upto Capacity (m2)			
Very Cold	Cold	Cool	Mild
68	80	108	124

- 10 Year Heat Exchanger Warranty
- 2 Year Parts and Labour Warranty



# LS 1500 Gas Fire



5 Star Efficiency



Burn Media



Double-sided



Single-sided



2 Speed Fan



Preheat Function



Wi-Fi



Air Filter



Logset



Overheat Safety



Indoor-Outdoor



Made in NZ

## Dimensions

	Height (mm)	Width (mm)	Depth (mm)	Outer Flue Diameter (mm)	Inner Flue Diameter (mm)
Appliance dimension	745	1935	435	75	50
Glass dimension	280	1500		N/A	

## Technical Information

Gas Input MJ/h Low	Gas Input MJ/h High	kW Output	Gas Type
15	40	9.2	NG & LPG

## Room Sizing

Heats upto Capacity (m2)			
Very Cold	Cold	Cool	Mild
78	92	125	142

- 10 Year Heat Exchanger Warranty
- 2 Year Parts and Labour Warranty



# Specification

## LS Gas Fire

Inbuilt power flued convection fan fire operated by a simple infra-red remote, or by the Rinnai Wi-Fi app that allows full thermostatic control as well as other features such as timers. Different burn media options available.

### Specification summary

	Input	Output*	Heating area**
LS 800F	14-35 MJ/h	3.3-8.3 kW	70-128 m <sup>2</sup>
LS 1000F	14-35 MJ/h	3.3-8.3 kW	70-128 m <sup>2</sup>
LS 1000	14-35 MJ/h	3.2-8.0 kW	68-124 m <sup>2</sup>
LS 1500	15-40 MJ/h	3.2-9.2 kW	78-142 m <sup>2</sup>

\* Will vary according to gas type and flue configuration

\*\* Will vary depending on geographical location in AU

Efficiency = > 75% (all models on high)

Gas type = NG or LPG

#### Please note

The heat output and heating areas will differ slightly for the single sided and double sided variants. Single sided models will be slightly more efficient.

#### Suitability

Ideal for living rooms and open plan areas. Versatile power flue system makes for easy installation in almost any living space, including bedrooms.

The LS Series is ideal for a new build installation.

#### Installation considerations

Room size—smaller rooms will heat up quickly, and due to the efficiency of the appliance, if in thermostatic mode, will reduce to a low flame profile.

Installation of the LS higher up the wall, in some room configurations, can create draughts due to the convection air being pushed out from the top of the appliance.

#### Data plate - 800/1000

Base of the combustion chamber, left hand side, on the convection fan access panel.

#### Data plate - 1500

Base of the combustion chamber towards the left hand side, between the gas control and convection fan access panel.

#### Convection fan

2-speed fan. Heat is distributed from the top of the appliance.

#### Gas connection

½ " BSP, the gas supply terminates inside the unit—lower left hand side of the appliance.

#### Ignition: Continuous spark electronic ignition.

**Noise level:** 37-45 dB(A)

#### Power flue

Inner 50mm, outer 70-80mm. Appliance must be installed with a Rinnai flue system.

#### Power consumption/electrical supply

High = 50 W

Standby = <8 W

The LS has a 1.5 m power cord with a three pin plug supplied. The power cord passes through a slot in the right hand side of the appliance.

#### Safety devices

Flame failure sensing system, pressure relief, overheat safety switch, air temperature sensor, thermal fuse, overcurrent fuse, and spark detection.

#### Temperature control

The LS can be operated using the basic infra-red remote, or for more features, such as timers and thermostatic control, using Rinnai's Wi-Fi fireplace controller app.

#### Weights

	Unit	Packaged
LS 800F	100kg	120kg
LS 1000F	100kg	125kg
LS 1000	100kg	125kg
LS 1500	110kg	140kg



# Unit dimensions

## LS Gas Fire dimensions

These are the unit dimensions only, not the framing dimensions. The centre of the glass is NOT the centre of the appliance.

LS 800F

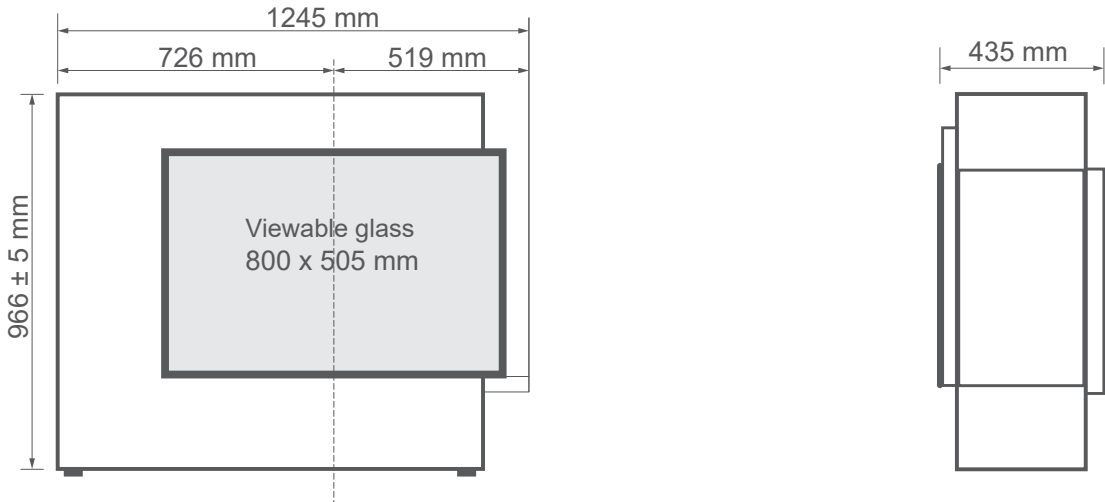

LS 1000/LS 1000F

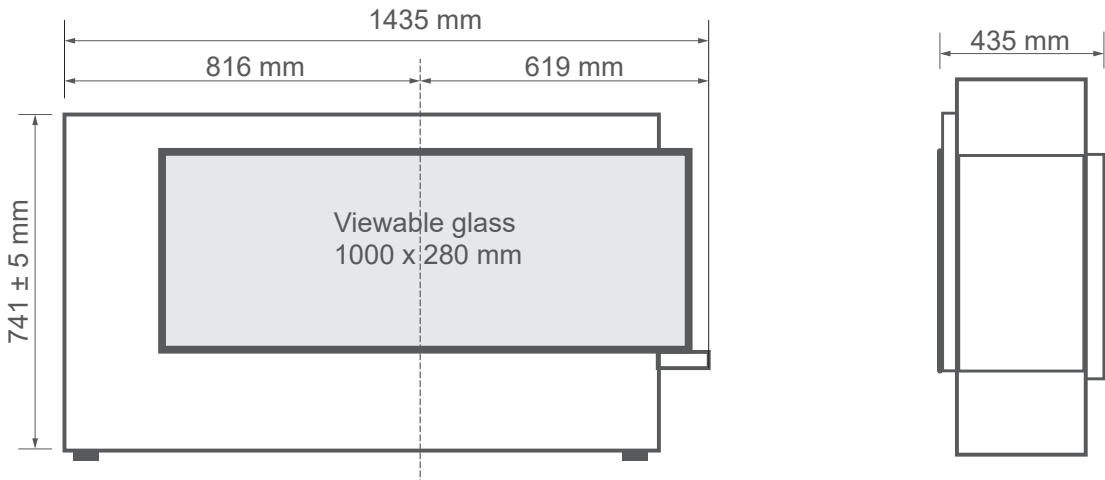

LS 1500

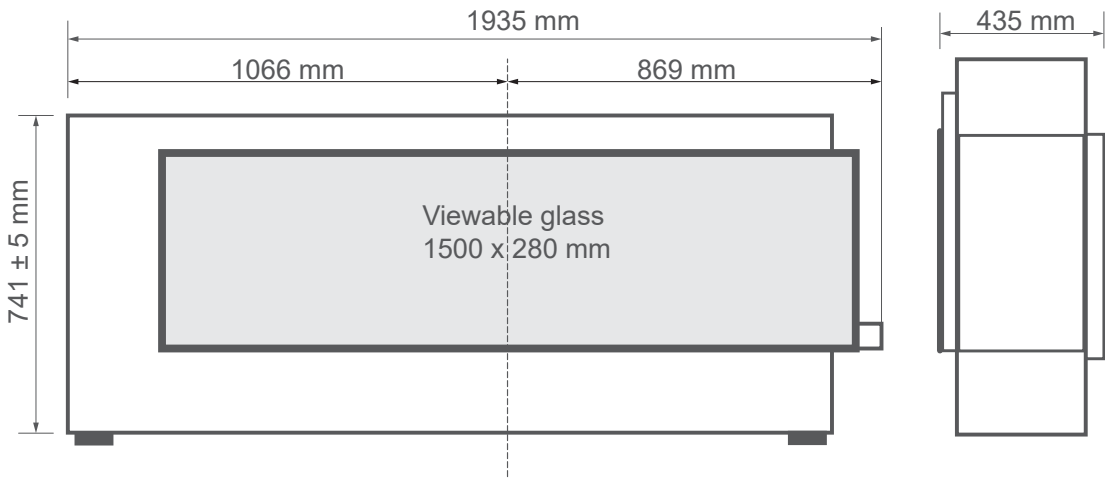

# Clearances

## Clearances from combustibles

The clearances listed below, measured from the edge of the glass, are minimum clearances unless otherwise stated.

### While the fire is operating

The appliance must not be installed where curtains or other combustible materials could come into contact with the fire. The 400mm side clearance includes side walls. The 1000mm clearance is in front of the fire.

### Floor protection

Heat emanating from this fire may over time affect the appearance of some materials used for flooring, such as, carpet, vinyl, cork or timber. This may be amplified if the air contains cooking vapours or cigarette smoke. To avoid this occurring, it is recommended a mat be placed in front of the appliance.

### Mantels and surrounds

Combustible mantels and surrounds require clearance from the unit to minimise the risk of fire.

Mantels and surrounds, made of combustible material such as wood are allowed providing they are outside the minimum clearances detailed below.

For every 50mm of added mantel depth there must be an additional 100mm of clearance from the edge of the glass.

For example:

#### Mantel depth: 'A' clearance required

300mm	500mm
350mm	600mm
400mm	700mm

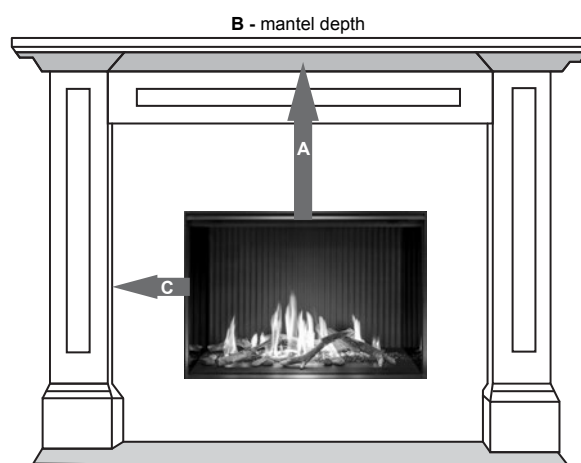
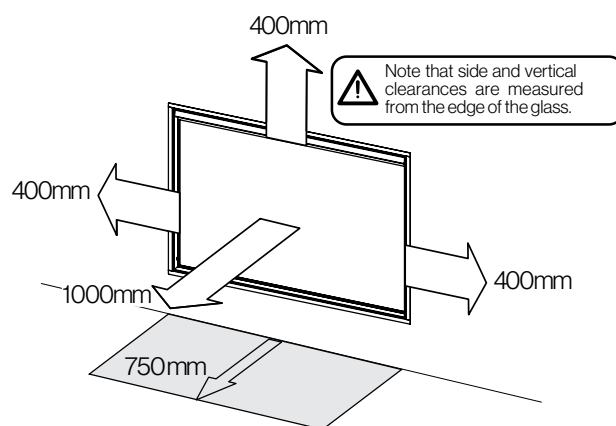

- A** Mantel needs to be a minimum of 400mm away from the edge of the glass.
- B** Maximum mantel depth at 400mm (A) is 250mm maximum.
- C** Surround needs to be a minimum of 400mm away from the edge of the glass.

# Hearths

## Hearth installation

Any hearth installed in the shaded area (shown below) must be capable of withstanding temperatures up to 100°C. Some laminated materials may buckle or delaminate when exposed to high levels of heat.

1. A 3 mm air gap between the hearth and lower fire lip is critical. This allows for air flow to critical components and for correct operation of the IR receiver.
2. The lower support rail is only required if the side rails are used, side rails are required for combustible wall linings.
3. The finishing trim latches are not needed if a hearth is installed, they can be snapped off if they are in the way.

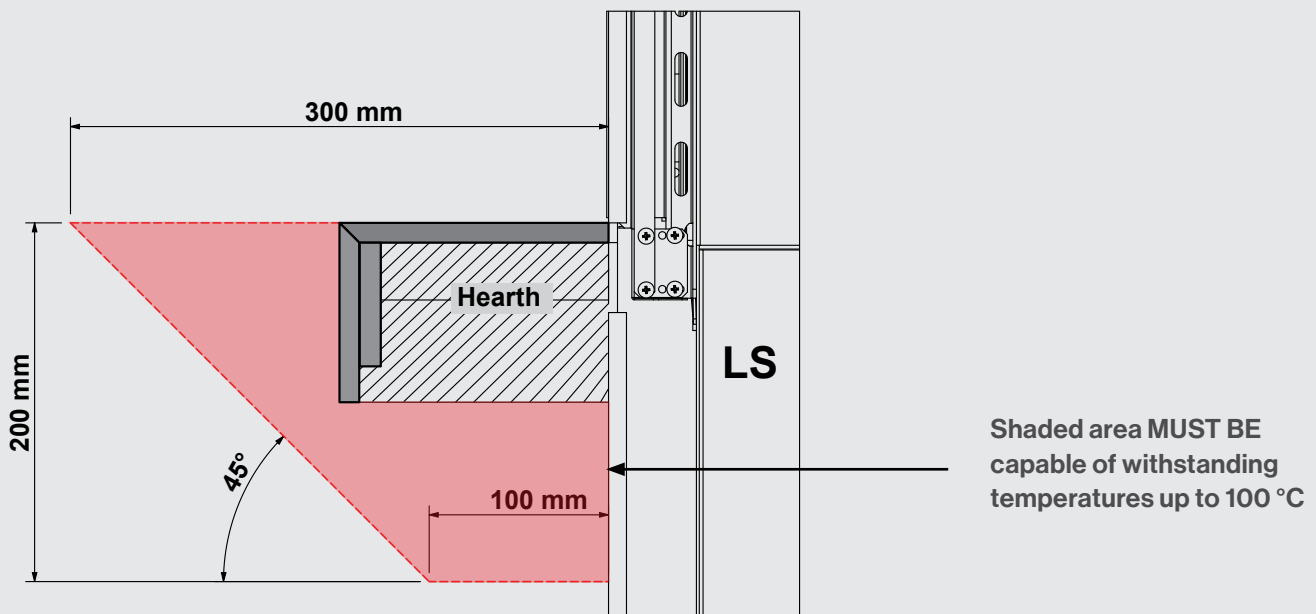

# TV installation

## TV installation above LS Gas Fire

The LS Gas Fire has a fan that distributes warm air from the top of the appliance out into the room. As warm air is dispersed outwards and not directly upwards, installation of a TV may be an option.

### Recommended clearances when installing a TV directly above the LS Gas Fire, or into a recess.

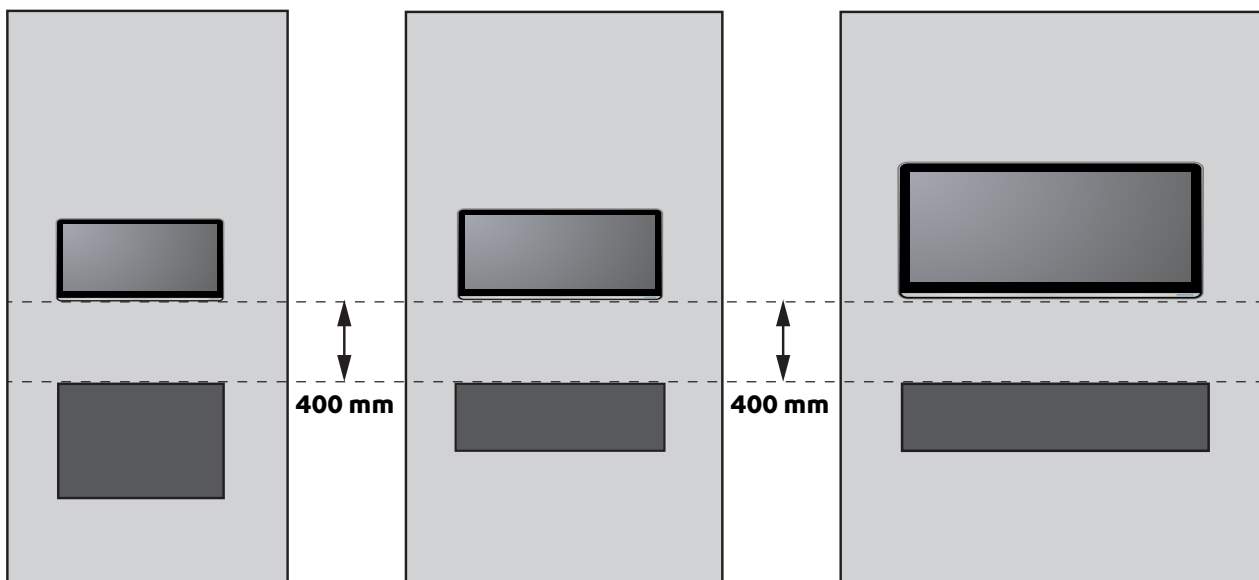

#### Always check with the TV manufacturer

It is up to the owner to check the TV installation with the TV manufacturer—some have warranty conditions that state a TV is not to be installed above a fireplace.

Rinnai does not accept any responsibility for damage to a TV resulting from the use of this information.

# Cavity ventilation

## Minimum cavity ventilation area

Four ventilation areas of at least 4000 mm<sup>2</sup> each, are required in the cavity, ideally adjacent to the bottom ends, and to the top ends, of the heater of the appliance. This is to allow room temperature air to enter the heater cavity at the bottom, and to exit at the top from the hotter areas of the fireplace cavity.

## Cavity ventilation design ideas

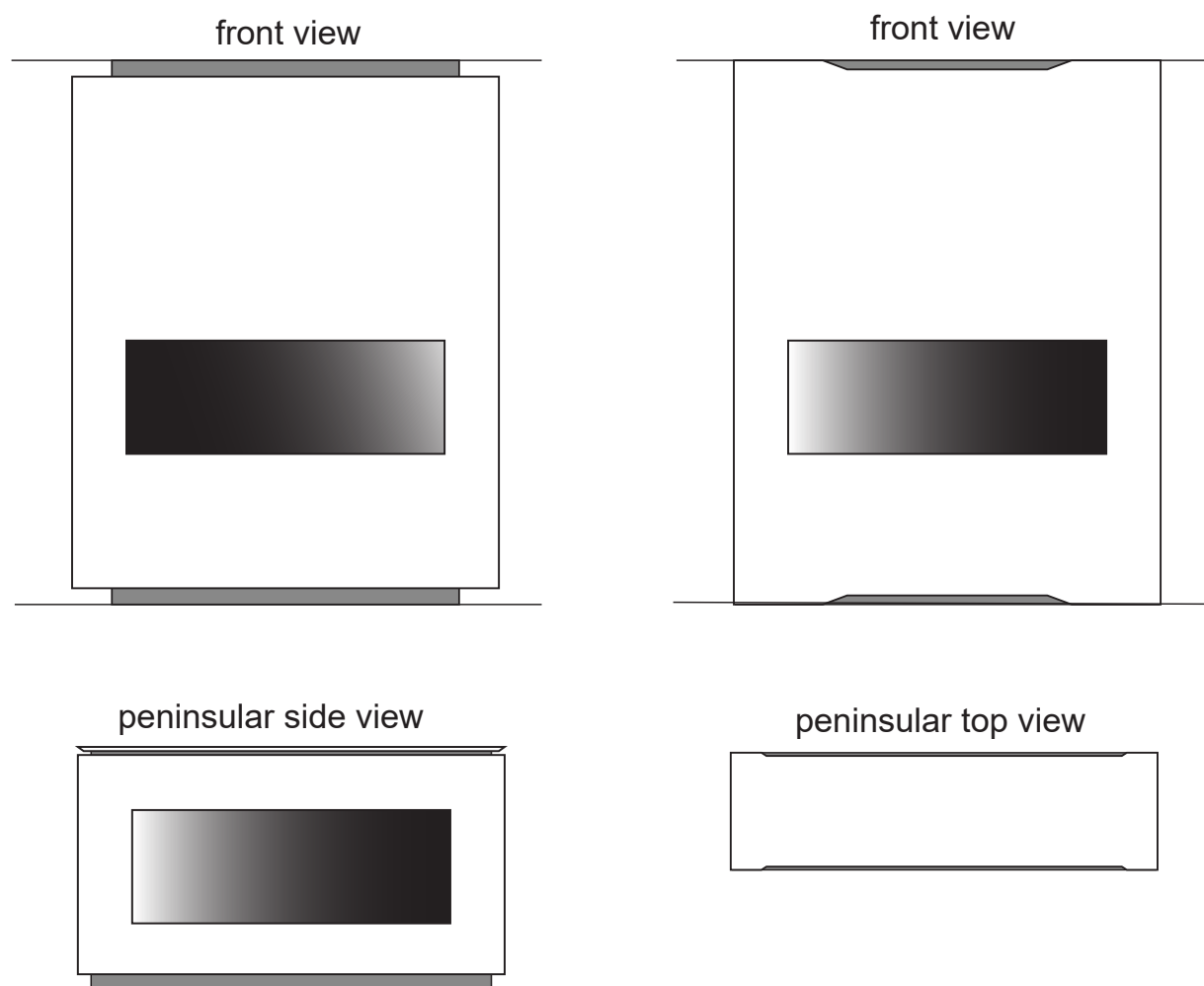

Ventilation can be either via placement of manufactured vents or a specifically sized opening or gap within the structure.

When a material such as wood, susceptible to heat damage, is installed directly above the appliance, it is important to allow a sufficient air gap and fit a non-combustible material underneath. All clearances specified in this manual must be provided. This can best prevent damage to the wooden or heat sensitive material.

# LS 800F framing dimensions

## Cavity framing



The cavity needs to be framed based on the centreline of the LS Gas Fire glass, NOT the opening size. Framing dimensions diagram shows studs are offset.

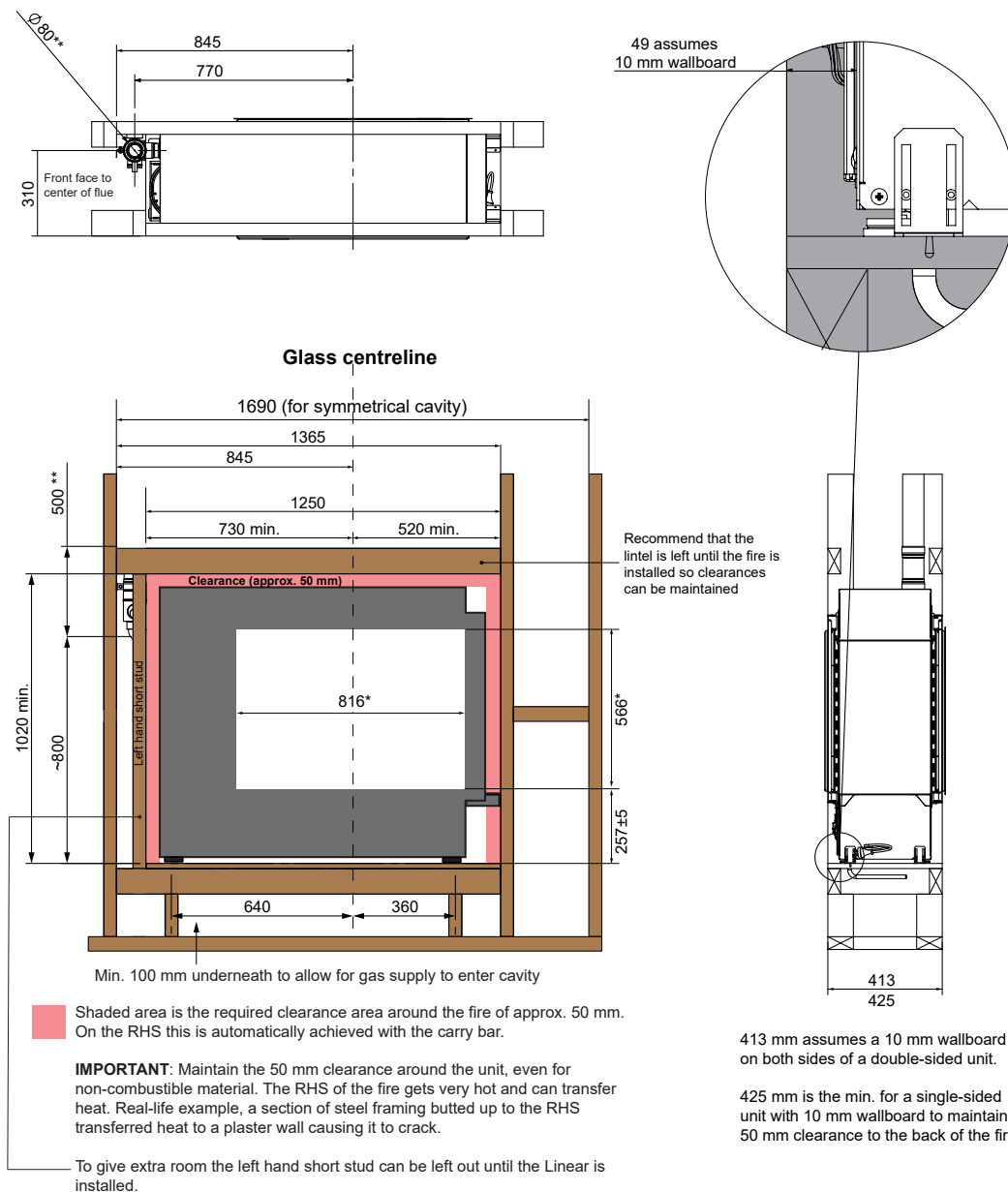

\* Minimum wallboard cutout if using the outer finishing trim

\*\* Maintain 25mm clearance to combustibles for the first 500mm of flue

- All dimensions are assuming a 10mm wallboard
- Studs and joists are required directly below the support feet of the fire
- Framing shown is 90 x 45mm
- Fire platform shown is 18mm plywood

# LS 1000/LS 1000F framing dimensions

## Cavity framing



The cavity needs to be framed based on the centreline of the LS Gas Fire glass, NOT the opening size. Framing dimensions diagram shows studs are offset.

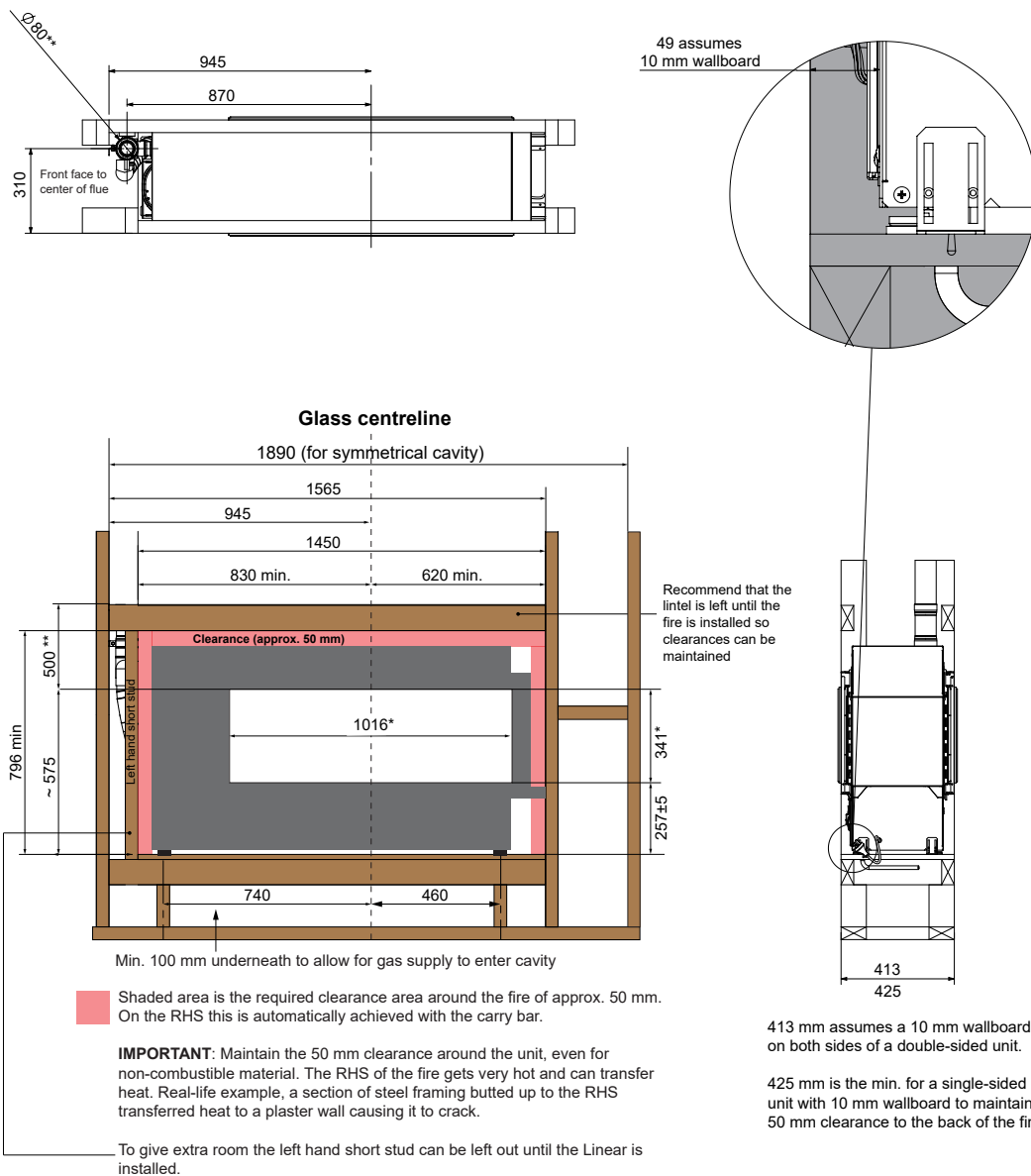

\* Minimum wallboard cutout if using the outer finishing trim

\*\* Maintain 25mm clearance to combustibles for the first 500mm of flue

- All dimensions are assuming a 10mm wallboard
- Studs and joists are required directly below the support feet of the fire
- Framing shown is 90 x 45mm
- Fire platform shown is 18mm plywood

# LS 1500 framing dimensions

## Cavity framing



The cavity needs to be framed based on the centreline of the LS Gas Fire glass, NOT the opening size. Framing dimensions diagram shows studs are offset.

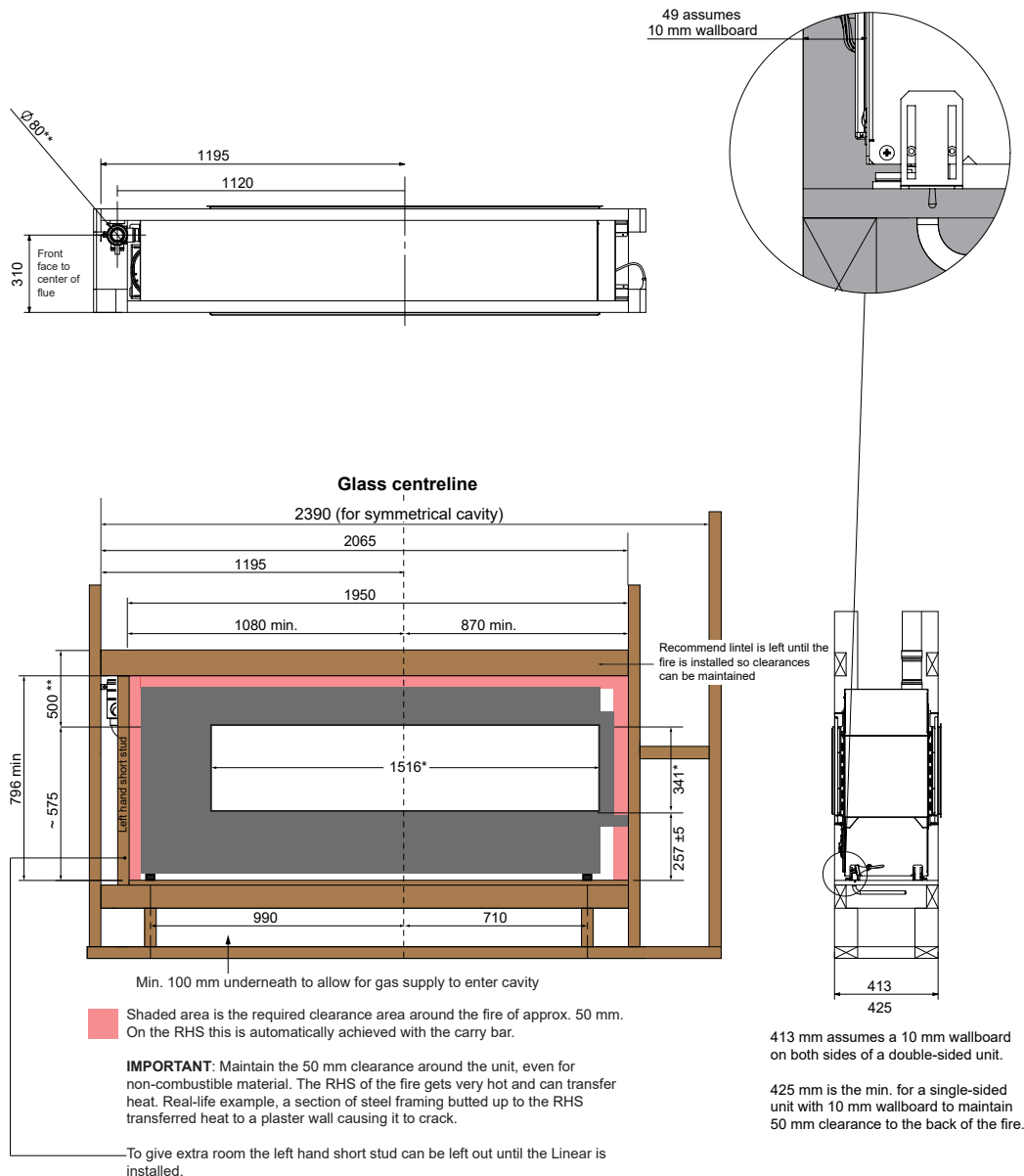

\* Minimum wallboard cutout if using the outer finishing trim

\*\* Maintain 25mm clearance to combustibles for the first 500mm of flue

- All dimensions are assuming a 10mm wallboard
- Studs and joists are required directly below the support feet of the fire
- Framing shown is 90 x 45mm
- Fire platform shown is 18mm plywood



# Indoor/Outdoor dimensions

## How to measure for Indoor/Outdoor LS Gas Fire

Use the below information in conjunction with the framing dimensions on the previous pages.

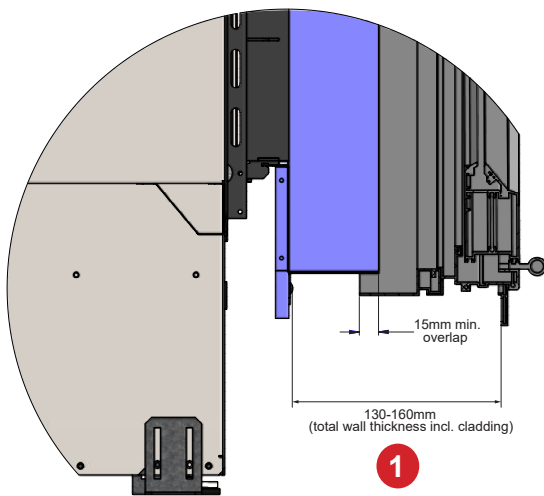

For a successful installation it's important the proposed window placement is checked to ensure the fire will fit. Allow enough room underneath the LS Gas Fire to be installed, and don't install the LS Gas Fire too high up the wall. The fire needs to be sized to match the window height. For the window dimensions refer to next page.

The LS 800F window opens sideways, left or right. The LS 1000/ LS 1000F and LS1500 window opens downwards.

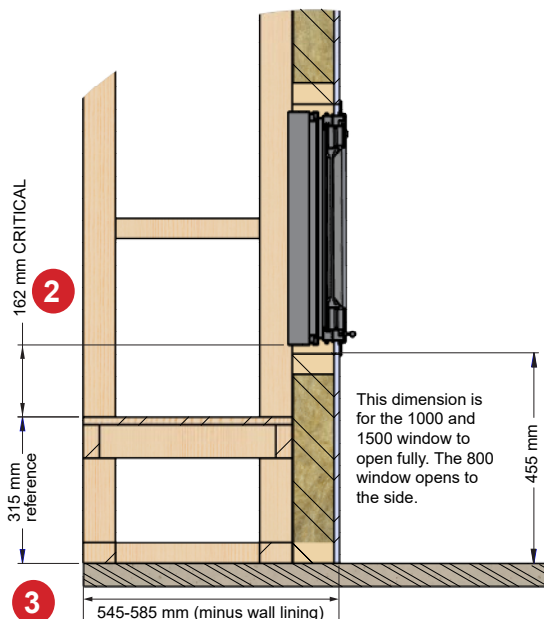

A plinth is constructed to position the fire in front of the outdoor window. This ensures the front lip of the fire is in line with the window lip, and ensures a complete view of the fire from the outside.

The critical dimensions for a successful and aligned installation are numbered 1, 2, and 3 on the diagrams. The 162mm dimension (number 2) is to the window sill — packing and/or feet adjustment may be required.

While the 455mm height allows for the window to be fully open (LS 1000/LS 1000F and LS 1500 models), it may be too high for the preferred viewing position of the fire. Adjust as required.

# Indoor/Outdoor window dimensions

## LS 800F window kit

LS800DFWKIT

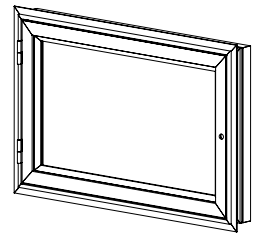
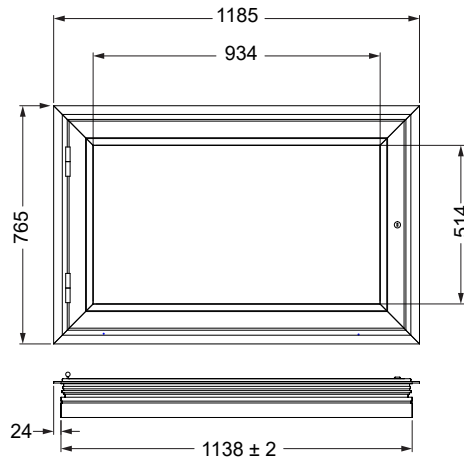

## LS 1000/LS 1000F window kit

LS1000DFWKIT

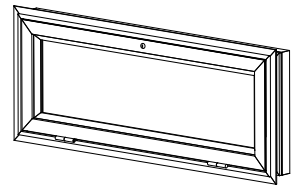
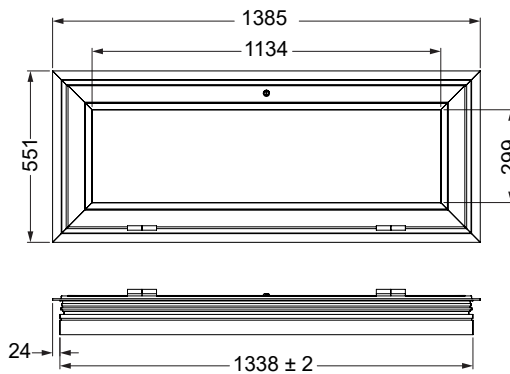

## LS 1500 window kit

LS1500DFWKIT

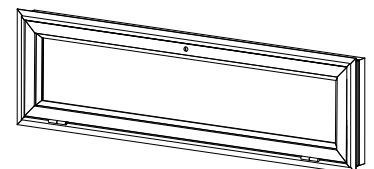
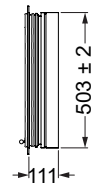
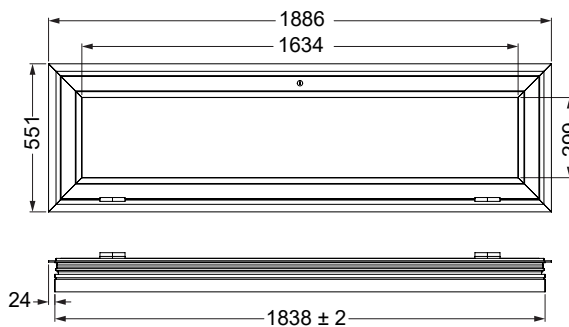

# LS Gas Fire burn media

## Codes for ordering LS Gas Fire

Ensure to obtain the correct engine code when ordering, as there are no part numbers for 800 FlameTech log set which are included with the LS Gas Fire.



**LS 800F and LS 1000F FlameTech log set**  
Innovative log technology, where flames emanate from the logs, displaying a more realistic flame picture.



**LS 1000 Designer log set**  
Mimicking natural drift wood and beach stones (ordered separately).



**LS 1000 Modern media**  
Modern media in the form of reflective black, crushed glass (ordered separately).



**LS 1500 Designer log set**  
Mimicking natural drift wood and beach stones (ordered separately).



**LS 1500 Modern media**  
Modern media in the form of reflective black crushed glass (ordered separately).

# LS Gas Fire accessories

- **LS wide trim**

## LS wide trim (50mm)

LS Gas Fire	Code
LS 800F	LS800WT50
LS 1000F / LS 1000	LS1000WT50
LS 1500	LS1500WT50

Installation of the LS requires the wall lining to be installed flush with the lips of the appliance. With plasterboard a smooth flush finish can be problematic. The outer finishing wide trim accessory, powder coated black, is designed to help achieve a smooth edge finish without plastering against the fire.

Not suitable for installations with a hearth.



# LS Gas Fire accessories

- **LS peninsular pack**



## LS peninsular pack (black)

LS Gas Fire	Code
LS 800F	LS800PENPCKL2
LS 1000F / LS 1000	LS10001500PENPCKL2
LS 1500F	LS10001500PENPCKL2

A series of metal panels (1mm thick) designed to fit around the fire to create a peninsular design on a double-sided model, as shown in the image below. The kit comes in two sizes, a short kit (end section 120mm), and a long kit (end section 200mm).

Each kit comes in three sections - two flat pieces and one folded endcap - powder coated black. LS peninsular pack size can be customised to suit your needs, please contact Rinnai for more information.

# LS flueing options

## Direct

Recommended Components	A	LSFDFK01, ESWFG
	B	LSFKIT01, ESPIPE900, ESWTERM, ESWFG

### Direct flue

Flue is run horizontally from appliance to the termination point. The appliance is designed to allow a direct flue to be terminated to the side using LSFDFK01 or the rear using LSFKIT01.

There MUST be a continuous 2° fall from heater connection point to the wall terminal.

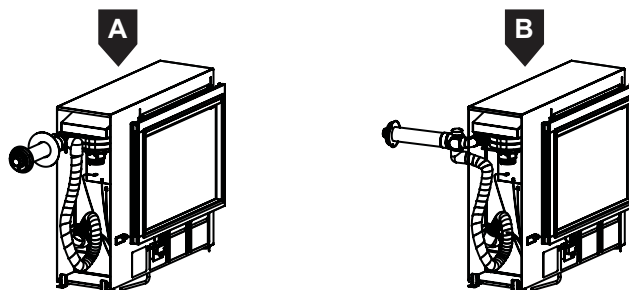

## Direct Extended

Recommended Components	A	LSFDFK01, ESPIPE900, ESWFG
	B	LSFKIT01, ESPIPE900, ESWTERM, ESWFG

### Direct extended flue

This option is the same as that of a Direct flue installation with the key difference being that additional lengths of ESPIPE900 are used to reach the termination point.

There MUST be a continuous 2° fall from heater connection point to the wall terminal.

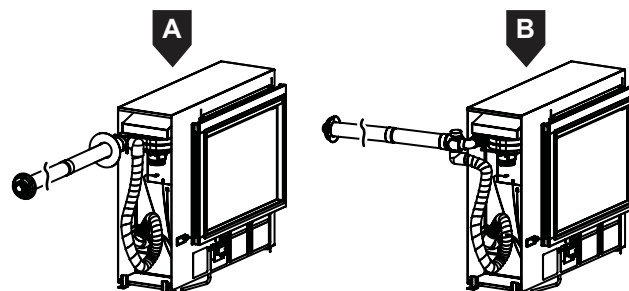

## Offset

Recommended Components	A	LSFDFKIT01, ESPIPE900, ESBEND, ESWFG
	B	LSFKIT01, ESPIPE900, ESBEND, ESWTERM, ESWFG

### Offset flue

Similar to extended, however the flue is offset with the use of ESBEND either horizontally or vertically to reach the termination point.

There MUST be a continuous 2° fall from heater connection point to the wall terminal.

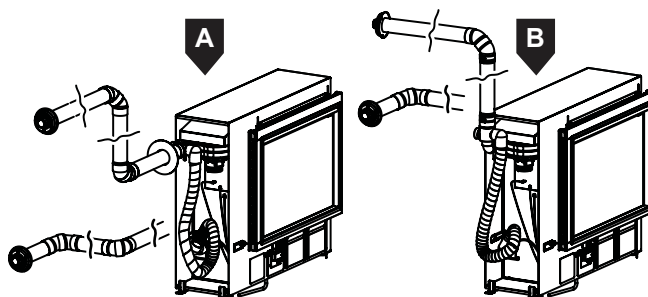

### Calculating length of flue

When considering the location of the fire care must be taken to ensure the flue path is free from obstructions such as studs, noggins, joists, braces, electrics etc.

**Maximum flue length = 8.5m**

**Maximum number of bends = three**

For every 90° bend, the overall length must be reduced by 1 m. For example, if an installation has three 90° bends, the maximum flue length can be 5.5m. The elbow component of the LS adaption flue kit (LSFKIT01) IS NOT counted as a 90° bend.

# LS flueing options

## Up & Over

Recommended Components	A	LSFDFK01, ESPIPE900, ESBEND, ESWFG
	B	LSKIT01, ESPIPE900, ESBEND, ESWTERM, ESWFG

### Up & Over flue

Similar to Offset, however the flue runs back over the appliance to reach the termination point. Noting that a minimum clearance of 55mm from the top of the heater engine MUST be maintained. Additionally ESBEND components can be used to create an offset around the flue obstacles.

There must be a continuous 2° fall from heater connection point to the wall terminal.

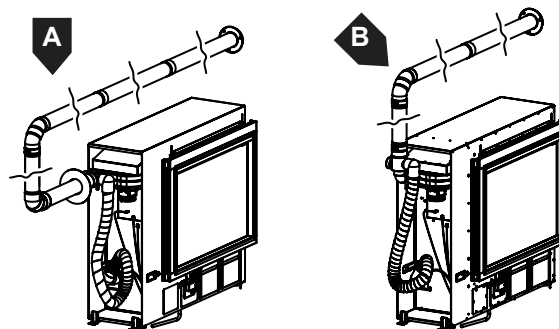

## Vertical - Roof Termination

Recommended Components	A	LSFKIT02, ESPIPE900
	B	LSFKIT02, ESPIPE900, ESBEND

### Vertical - roof termination flue

Flue is run vertically from the appliance to the termination point, this is usually via an internal wall cavity. ESBEND components can be used to create an offset around the flue obstacles.

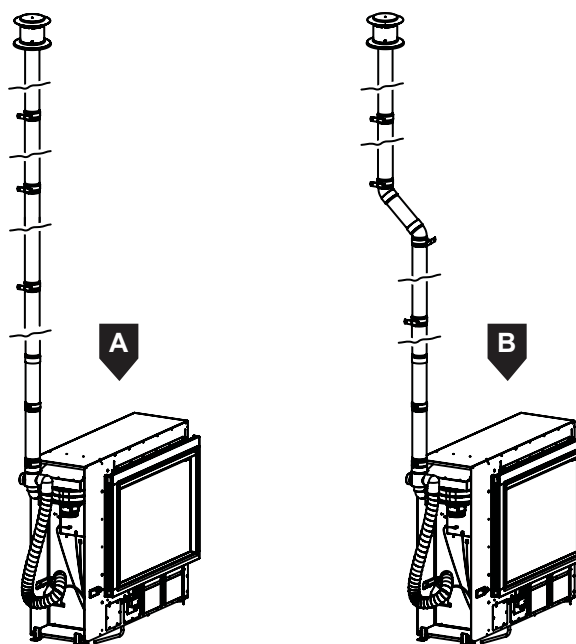

### Short flue installations

For lowest cost, optimal performance, ease of installation and servicing, Rinnai recommend short flue installations (less than 3m) are considered before all other options.

# LS flueing options

## Vertical - Wall Termination

Recommended Components	A	LSFKIT01, ESBEND, ESPIPE900, ESWKIT2
	B	LSFKIT01, ESBEND, ESPIPE900, ESWKIT2
	C	LSFDFK01, ESBEND, ESPIPE900, ESWKIT2

### Vertical - wall termination

An on-wall terminal using ESWKIT2 is for when the flue is run vertically from the appliance through an external to the termination point, and a roof terminal or a Direct flue option are not available. ESBEND components can be used to create an offset around the flue obstacles.

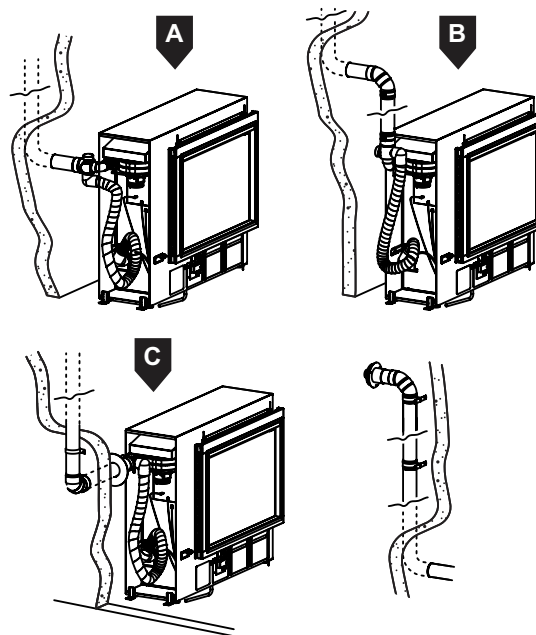

## Down & Under / Out

Recommended Components	A	LSFKIT01, ESBEND, ESPIPE900, ESWTERM, ESWFG
	B	LSFKIT01, ESBEND, ESPIPE900, ESWTERM, ESWFG
	C	LSFKIT01, ESBEND, ESPIPE900, ESWTERM, ESWFG

### Vertical - wall termination

Similar to Vertical Internal Wall, however the flue is directed down and under the floor to the termination point. This can be in any direction including back and under the heater. ESBEND components can be used to create an offset around the flue obstacles.

There MUST be a continuous 2° fall from heater connection point to the wall terminal. The terminal MUST NOT be terminated under the floor spaces.

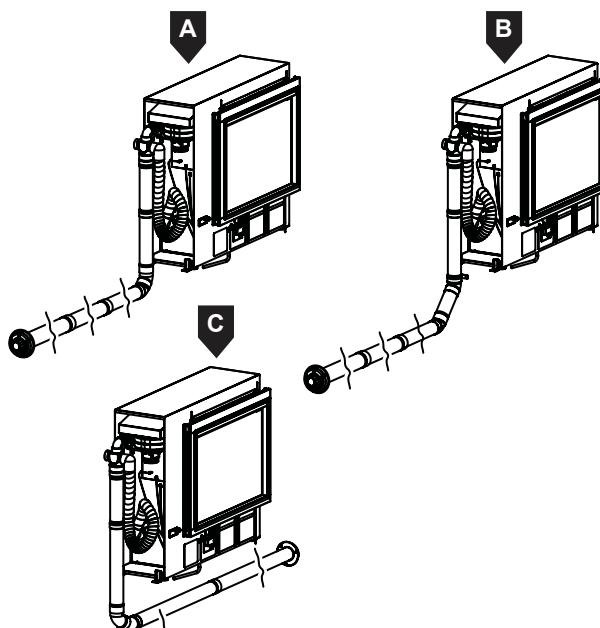

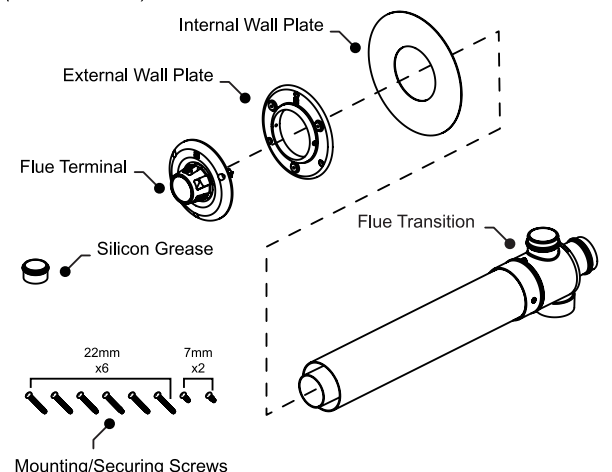
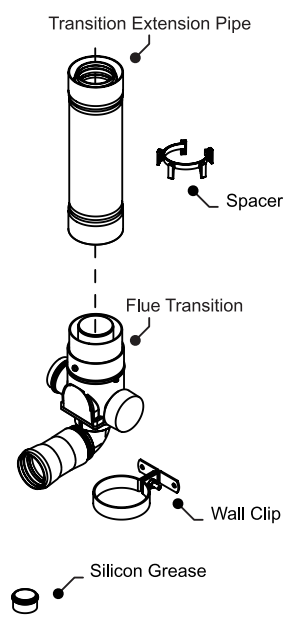
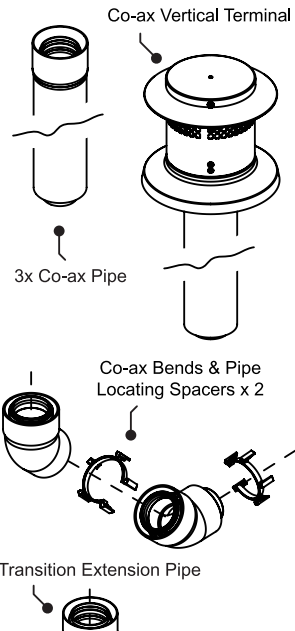
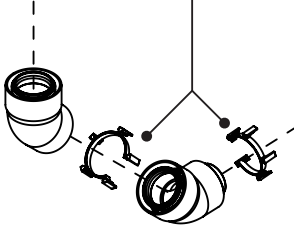
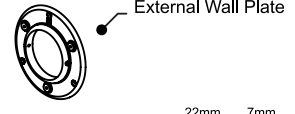
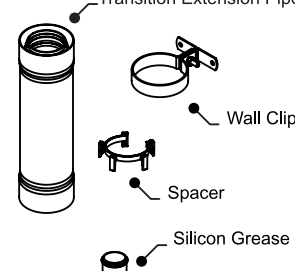
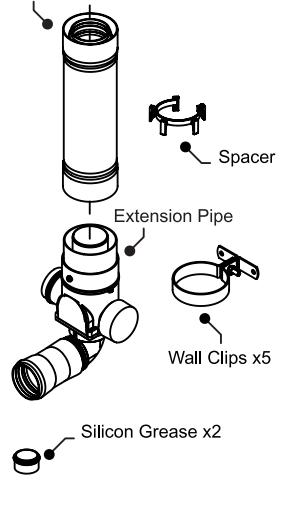
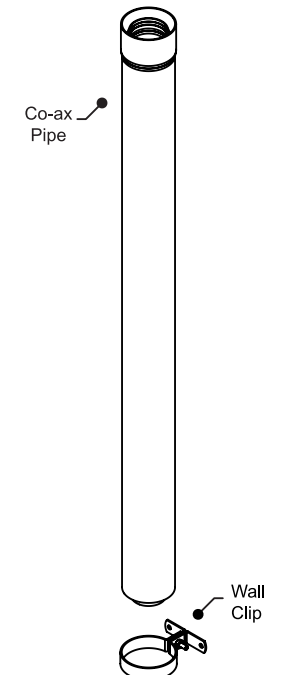
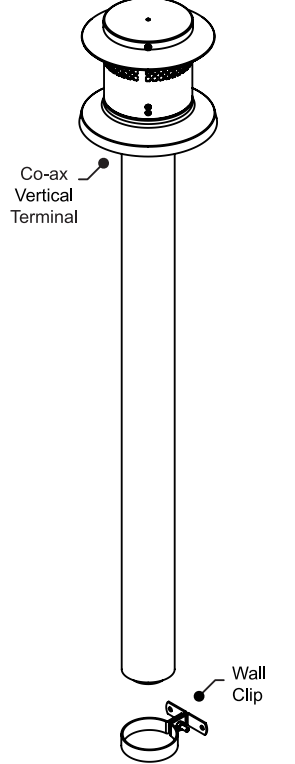
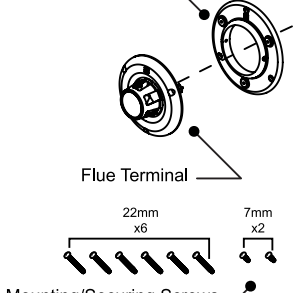
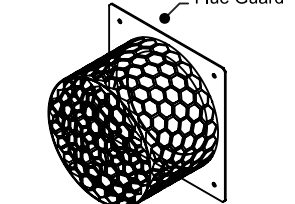
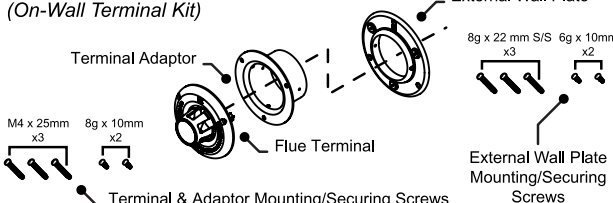

# LS flue kits & components

<p><b>LSDFK01</b> (Direct Flue Kit)</p>  <p>Internal Wall Plate</p> <p>External Wall Plate</p> <p>Flue Terminal</p> <p>Silicon Grease</p> <p>Flue Transition</p> <p>22mm x6</p> <p>7mm x2</p> <p>Mounting/Securing Screws</p>	<p><b>LSFKIT01</b> (Flue Adaption Kit)</p>  <p>Transition Extension Pipe</p> <p>Spacer</p> <p>Flue Transition</p> <p>Wall Clip</p> <p>Silicon Grease</p>	<p><b>LSFKIT02</b> (Extended Flue Adaption Kit)</p>  <p>Co-ax Vertical Terminal</p> <p>3x Co-ax Pipe</p> <p>Co-ax Bends &amp; Pipe Locating Spacers x2</p> <p>Transition Extension Pipe</p> <p>Spacer</p>	
<p><b>ESBEND</b></p> <p>Co-ax Bends &amp; Pipe Locating Spacer x2 (<b>BOTH</b> spacers are required for all offset and extended offset installations!)</p> 	<p><b>ESPLATE</b></p> <p>External Wall Plate</p>  <p>22mm x3</p> <p>7mm x2</p> <p>Mounting/Securing Screws</p>	<p><b>LSFEXTKIT01</b></p>  <p>Transition Extension Pipe</p> <p>Wall Clip</p> <p>Spacer</p> <p>Silicon Grease</p>	<p>Transition Extension Pipe</p>  <p>Extension Pipe</p> <p>Wall Clips x5</p> <p>Silicon Grease x2</p>
<p><b>ESPIPE900</b></p>  <p>Co-ax Pipe</p> <p>Wall Clip</p>	<p><b>ESROOFCOWL</b></p>  <p>Co-ax Vertical Terminal</p> <p>Wall Clip</p>	<p><b>ESWTERM</b></p>  <p>External Wall Plate</p> <p>Flue Terminal</p> <p>22mm x6</p> <p>7mm x2</p> <p>Mounting/Securing Screws</p>	<p><b>ESWFG</b></p>  <p>Flue Guard</p>
<p><b>ESWTKIT2</b> (On-Wall Terminal Kit)</p>  <p>External Wall Plate</p> <p>Terminal Adaptor</p> <p>Flue Terminal</p> <p>M4 x 25mm x3</p> <p>8g x 10mm x2</p> <p>Terminal &amp; Adaptor Mounting/Securing Screws</p> <p>8g x 22mm S/S x3</p> <p>6g x 10mm x2</p> <p>External Wall Plate Mounting/Securing Screws</p>			





**Rinnai Australia Pty Ltd**

ABN 74 005 138 769

100 Atlantic Drive,  
Keysborough, Victoria 3173

For further information  
call 1300 555 545 or visit  
[rinnai.com.au](http://rinnai.com.au)

**TOTAL HOME COMFORT**



**Rinnai**