

MODEL  
REU-CUG1



# Smartstart® – REU-CUG1

## Installation Manual

# Rinnai



## BEFORE USING THIS APPLIANCE

Before proceeding with the operation or installation read this manual thoroughly and gain a full understanding of the appliance, to ensure safe and correct use.

This appliance must be installed in accordance with:

- Manufacturer's Installation Instructions
- Current AS/NZS 3000, AS/NZS 3500 & AS/NZS 5601
- Plumbing Code of Australia (PCA)
- Local Regulations and Municipal Building Codes including local OH&S requirements

This appliance must be installed, maintained and removed by an Authorised Person.

For continued safety of this appliance it must be installed and maintained in accordance with the manufacturer's instructions.



This Appliance complies  
with AS 3498  
SAI GLOBAL LIC. W208



All pictures and diagrams in this manual are indicative for explanatory purposes only. There may be differences between these and the products supplied, depending on the model. Actual unit specifications should be reviewed.

# TABLE OF CONTENTS

<b>Before Using This Appliance</b> .....	<b>4</b>
<b>Regulatory Information</b> .....	<b>4</b>
Notice to Victorian Consumers .....	4
<b>General Installation Information</b> .....	<b>5</b>
Regulations .....	5
Applicable Models .....	5
Smartstart Kit Contents .....	5
<b>Operation</b> .....	<b>6</b>
Principle of Operation .....	6
<b>Location</b> .....	<b>7</b>
Appliance Location .....	7
Service Connection Points .....	8
Valves .....	8
Pipework .....	8
Mounting The Smartstart Module .....	8
Communication Cable .....	9
Manual Activation Switch .....	9
Smartstart – Manual Activation Switch using Clipsal 30PBBP-WE switch .....	9
Water Controllers .....	10
Heated Water Delivery Temperature .....	10
<b>Commissioning</b> .....	<b>12</b>
Testing and Commissioning .....	12
<b>Specifications</b> .....	<b>13</b>
Wiring Diagram .....	13
Dimensional Drawings .....	14
<b>Contacts</b> .....	<b>16</b>

# WARNINGS & IMPORTANT INFORMATION



## BEFORE USING THIS APPLIANCE

Before proceeding with the operation or installation read this manual thoroughly and gain a full understanding of the appliance, to ensure safe and correct use.

Always comply with the following precautions to avoid dangerous situations and to ensure optimum performance.

Failure to carefully read and follow all instructions in this manual can result in equipment malfunction, property damage, personal injury and/or death.

**DANGER:** Indicates an imminently hazardous situation which, if not avoided, will result in personal injury or death.

**WARNINGS:** Indicates a potentially hazardous situation which, if not avoided, could result in personal injury or death.

**CAUTIONS:** Indicates a potentially hazardous situation which, if not avoided, could result in minor or moderate injury or damage to the appliance. It may also be used to alert against unsafe practices.



## REGULATORY INFORMATION

This Appliance **MUST BE** installed correctly by an appropriately licensed tradesperson. The installation of gas, water, and electricity **MUST** conform to local regulations, including local OH&S requirements. The installation **MUST** also comply with the instructions supplied by Rinnai.

Please keep this instruction booklet in a safe place for future reference.

All dimensions referred to in these instructions are in millimetres, unless otherwise specified.

### Notice to Victorian Consumers

This appliance **MUST** be installed by a person licensed with the Victorian Building Authority. Only a licensed person will have insurance protecting their workmanship. So make sure you use a licensed person to install this appliance and ask for your Compliance Certificate.

For further information contact the Victorian Building Authority on 1300 815 127.



**THE SMARTSTART SYSTEM MUST BE MOUNTED ON A VERTICAL WALL OR STRUCTURE.**

**THE SMARTSTART SYSTEM MUST NOT BE USED BY ITSELF OR WITH ANOTHER MANUFACTURERS WATER HEATER OR WATER CONTROLLERS.**

- The Rinnai Smartstart system is Certified and compatible **ONLY** with the Rinnai Water Heaters REU-VR, REU-VCM, REU-VRM, REU-KM, REU-A, REU-AM, REU-E and REU-N Series.
- At least one Water controller **MUST** be used in conjunction with the water heater and the Smartstart system, except where it is a gas boosted solar installation when a Water Controller cannot be used.
- Alternatively, if Water Controllers cannot be used, a manual push button activation switch (available from electrical wholesalers) connected to the additional wiring loom supplied with the Smartstart **MUST** be used.
- The installation of the water heater and water controllers **MUST** be performed in accordance with the 'Operation / Installation manual' supplied with the water heater.
- The Smartstart system is designed for domestic installations. However, it may be suitable for certain non domestic installations. Contact Rinnai for more information.



## MANDATORY INSPECTION PRIOR TO INSTALLATION

Immediately report any damage or discrepancies to the Supplier of the appliance. This appliance was inspected and tested at the time of manufacture and packaging, and released for transportation without known damage. Upon receipt, inspect the exterior for evidence of rough handling in shipment. Ensure that the appliance is labelled correctly for the gas and electrical supply, and/or other services it is intended to be connected to.

For safety and warranty purposes, appliances that may be damaged or incorrect **MUST NOT** be installed or operated under any circumstances. Installation of damaged or incorrect appliances may contravene local government regulations. Rinnai disclaims any liability or responsibility whatsoever in relation to the installation or operation of damaged or incorrect appliances.

# GENERAL INSTALLATION INFORMATION

## REGULATIONS

This appliance must be installed in accordance with:

- Current AS/NZS 3000, AS/NZS 3500 and AS/NZS 5601
- Rinnai Installation Instructions
- Plumbing Code of Australia (PCA)
- Local regulations and municipal building codes including local OH&S requirements

## APPLICABLE MODELS

The Rinnai Smart system is Certified and is compatible only with Rinnai gas continuous flow water heater models that are listed as follows:

- REU-VR, REU-VRM, REU-VCM, REU-KM, REU-A, REU-AM, REU-E and REU-N Series.
- At least one Water controller must be used in conjunction with the water heater and the Smartstart system, except where it is a gas boosted solar installation when a Water Controller cannot be used.
- Alternatively, if Water Controllers cannot be used, a manual push button activation switch (available from electrical wholesalers) connected to the additional wiring loom supplied with the Smartstart **MUST** be used.
- The installation of the water heater and water controllers **MUST** be performed in accordance with the 'Operation / Installation manual' supplied with the water heater.
- The Smartstart system is designed for domestic installations. However, it may be suitable for certain non domestic installations. Contact Rinnai for more information.

## SMARTSTART KIT CONTENTS

The Rinnai Smartstart kit comprises an enclosure containing circulating pump, water connections for cold water inlet, cold water outlet and heating loop return, control wiring and printed circuit board. It is fitted with an electric power cord with three pin plug suitable for connection to a 240V 50Hz 10Amp GPO. It is also fitted with a control lead for connection to the Rinnai water heater. Refer to Figure 1.

A Switch Harness (Part No. U268-605) is also provided for connection to a Manual Activation Switch (if required).

**The Rinnai Smartstart kit does not include:**

- 240V 50Hz 10Amp GPO
- Heating loop flow and return pipework
- Gas and water isolating valves
- Control valves (non return valve, pressure limiting valve, expansion relief valve)
- Plumbing Connections between the Smartstart enclosure and Rinnai Water Heater and Rinnai Water Controllers

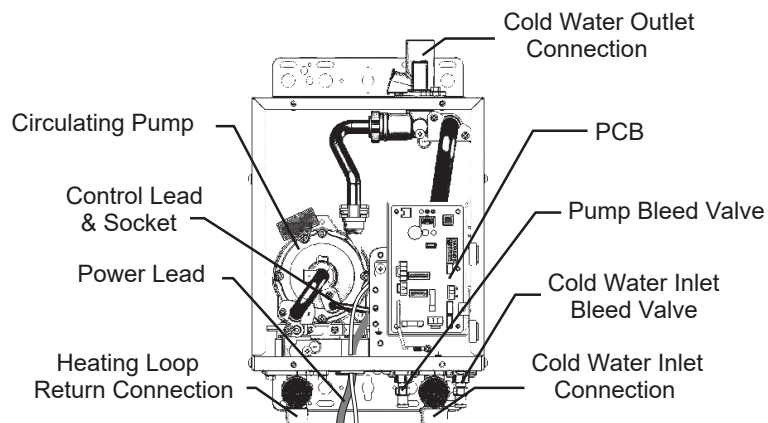

Figure 1. Kit contents

# OPERATION

## PRINCIPLE OF OPERATION

The Smartstart system heats the water in the pipework water connected between the water heater and the hot water outlets before any outlets are opened using the 'flow and return' pipework principle. This results in water savings and reduced waiting time for heated water delivery from the outlet when opened.

Traditional 'flow and return' systems usually keep the water in the pipework heated continuously. The Smartstart system however, only heats the water before the outlet is opened. This results in significant energy savings because water is not heated unnecessarily whilst retaining the benefits of traditional flow and return systems.

A schematic of the Smartstart system installed in conjunction with a Rinnai water heater and water controller is shown in Figure 2 below.

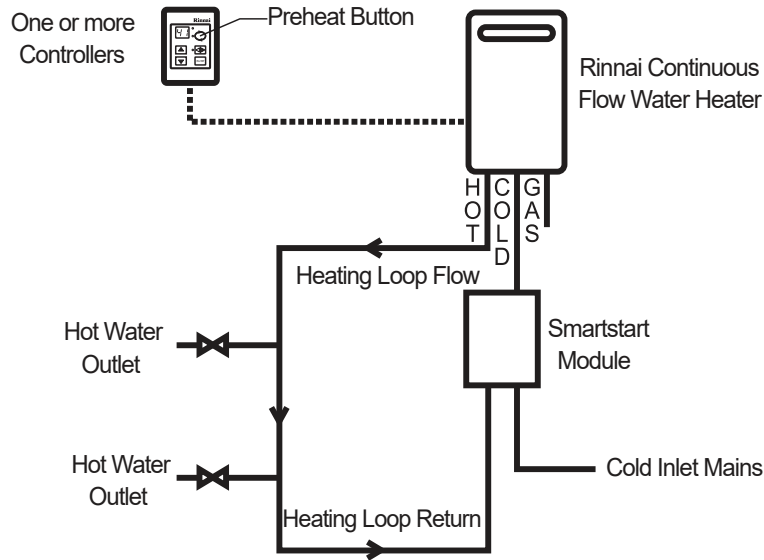

**Figure 2. Smartstart System**

The Smartstart system works as follows:

1. Before hot water is required, the user activates the Smartstart system by pressing the 'preheat' button on the water controller or by pressing the Manual Activation Switch.
2. This activates the Smartstart system and the integral pump is switched on.
3. Water flows from the pump and passes through the water heater. This in turn activates the water heater burner and water in the flow and return heating loop begins to heat.
4. When the Smartstart control module senses that the water in the full length of the flow and return heating loop has been heated, the pump and water heater stop operating.
5. The user opens the desired hot water outlet. Preheated water will be delivered from the flow and return heating loop to the outlet.

## APPLIANCE LOCATION

Refer to diagram below (Figure 3)

- Location and clearance requirements for the Rinnai continuous flow water heaters are detailed in the Installation Instructions supplied with it.
- The Smartstart module weighs 7.5 kg and the wall or structure on which it is to be mounted must be capable of supporting the combined weight of the Smartstart unit, water heater and any associated pipework.
- Both the water heater and Smartstart module must be in an accessible location. Sufficient clearance shall allow access to, and removal of, all serviceable components. Water heater and Smartstart modules must not be mounted higher than 3.5 metres from the ground or floor level unless the customer can arrange permanent and safe access or can arrange another means of access, for example, by means of scissor or boom lifts.
- The Smartstart module is usually located below the Rinnai water heater. However, it can be mounted anywhere within a 1.0 metre distance from the water heater (length of communication cable is one metre).
- A 240V 50Hz 10Amp weatherproof external earthed power point shall be provided adjacent to the Smartstart module (the power cord is 1.5 metres long).
- Alternatively, the water heater and Smartstart module can share the same power point provided it is of the dual outlet type.
- Double adaptors and extension leads must not be used.
- The power point must be kept clear of pipework connections, relief valve discharge points and the water heater flue outlet.

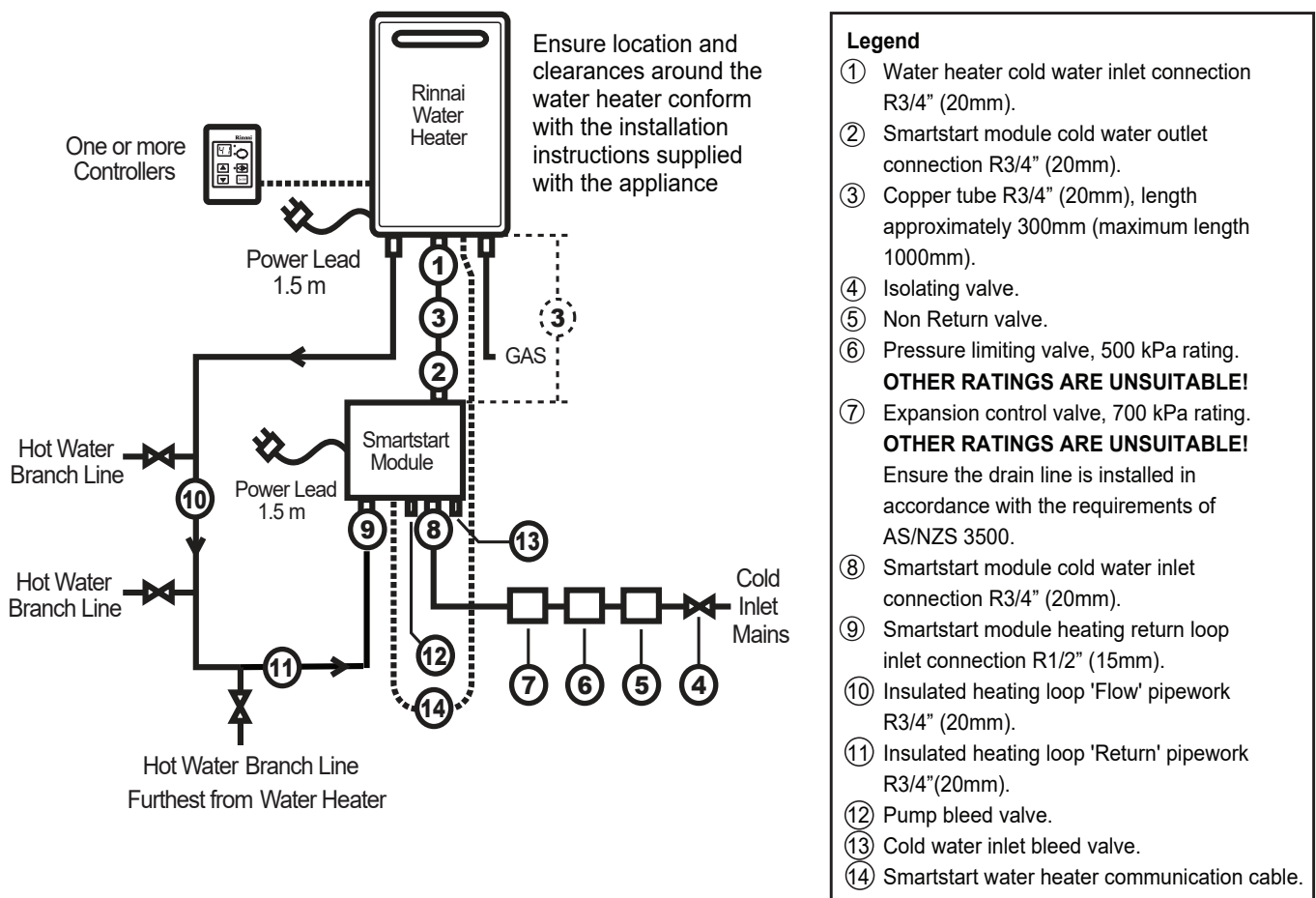

Figure 3.



**Total length of items 10 & 11 not to exceed 60 metres. Flow and return pipe sizes smaller R 3/4" (20mm) may result in inadequate performance.**

### SERVICE CONNECTION POINTS

Positions and sizes of the connection points to the water heater and pipework are shown in Figure 3 and the Dimensional drawings.

### VALVES

- Approved isolation and non return valves must be fitted to the cold water inlet.
- A combination isolating and non return valve may be used. Approved pressure limiting and expansion control valves must also be fitted. A combination pressure limiting and expansion control valve may be used. The pressure limiting valve must be rated at 500 kPa.
- The Expansion Control valve must be rated at 700 kPa. **OTHER RATING COMBINATIONS ARE NOT SUITABLE!**
- Valves must not be connected directly to the Smartstart module or Rinnai water heater.
- It may be necessary to fit a temperature limiting device for delivery to areas used primarily for the purposes of personal hygiene. Refer to the 'Heated Water Delivery Temperature' section of this document.

### PIPEWORK

- All hot water pipework should be insulated to optimise performance and minimise energy wastage. This may also be required by local regulations.
- The flow section of the pipework should be R3/4" (20mm) type B copper or equivalent. The return section of the pipework should be R3/4" (20mm) type B copper or equivalent. Total combined length of the flow and return pipe should not exceed 60 metres.
- The branch lines from the flow and return pipework to the hot water outlets should be sized in accordance with AS/NZS 3500.

### MOUNTING THE SMARTSTART MODULE

The Smartstart module is usually located below the Rinnai water heater. However, it can be mounted anywhere within a 1.0 metre distance from the water heater. These instructions assume it is located below the water heater.



**Do not remove the front cover of the Smartstart or the water heater unless the power supply is isolated. It is not necessary to remove the front cover of either appliances for the purposes of mounting the Smartstart module.**

1. Draw a line vertically down from the cold water inlet connection of the Rinnai water heater.
2. Mount the Smartstart module so the top edge of the enclosure is approximately 300 mm below the Rinnai water heater with the water outlet connection of the Smartstart module in line with the water inlet connection of the Rinnai water heater as shown in Figure 3 on page 7.
3. Fasten the Smartstart module to the wall or supporting structure. The top bracket has a keyhole slot so that the Smartstart module can be positioned by hanging it on one screw, then the other screws can be secured.
4. Connect a piece of R3/4" (20mm) type B copper or equivalent between the outlet of the Smartstart module and the cold water inlet of the Rinnai water heater.
5. Connect the isolating, non return, pressure limiting and expansion control valves and an adequately sized cold water supply pipe to the cold water inlet of the Smartstart module.
6. Plan the route of the 'flow and return' pipework to ensure the shortest distance between the pipework and the hot water outlets.
7. Connect the 'flow and return' pipework between the hot water outlet of the Rinnai water heater and the heating loop return connection on the Smartstart module. Insulate pipework. The 'return' section of the pipework should be connected after the branch line furthest away from the water heater.
8. Install branch lines from the pipework to hot water outlets.



**Install temperature limiting device in accordance with the 'Heated Water Delivery Temperature' section of this document.**



## COMMUNICATION CABLE

- Electronic signals are communicated between the Smartstart module and the Rinnai water heater via the communication cable already fitted to the Smartstart module except when the system is a gas boosted solar or more than four (4) activation locations are required as the Manual Activation switch method will be necessary.
- The communications cable is connected to the remote control connection terminals on the Rinnai water heater in the same way as cables from the water controller(s). Refer to the 'WATER CONTROLLERS' section of the 'Operation / Installation Manual' supplied with the Rinnai water heater for details.

## MANUAL ACTIVATION SWITCH

- To obtain the full benefits of the water heater and Smartstart system, water controllers should be used. However, it is possible to use a manual activation switch to activate the Smartstart system if water controllers are not fitted.



This type of switch must be used with a Smartstart that is operating on a solar system. Refer to Figure 7 on page 11.

### Parts required:

- Two core sheathed (double insulated) flex with minimum cross sectional area of 0.5 mm<sup>2</sup>.
- Switch Harness (Part No. U268-605) this comes supplied with the Smartstart system.
- One or more manual activation switch(es). Suggested part is Clipsal 30PBBP-WE switch.

### Procedure:

- Install the manual activation switch(es) in the desired location in accordance with manufacturer instructions.
- Run the cable between the manual activation switches and the Smartstart system.



If more than one manual activation switch is used then the cables will need to be connected in parallel before entering the Smartstart system. Only one cable can be connected to the terminals of the Smartstart system.

- Run the cable into the Smartstart enclosure using the same entry point as the communication cable fitted between the Smartstart and the Rinnai Water heater.
- The switch harness is connection between the cable from the manual activation switch(es) and the Printed Circuit Board (PCB) of the Smartstart. Connect the two wires from the manual activation switch cable to the Blue and Black wires on the switch harness (polarity does not apply). If an LED indicator is used, connect the two wires from the LED indicator to the Red and Black wires on the switch harness. (The LED required is 12V 5 mA Maximum). **Note: that the Orange wire on the switch harness is not used.**
- Plug the switch harness into the PCB as shown in the "Wiring Diagram" on page 13.

## SMARTSTART – MANUAL ACTIVATION SWITCH USING CLIPSAL 30PBBP-WE SWITCH

There is no commercially available switch with an integral LED that will operate at 12 Volts D.C. The most common devices have a 240 Volt A.C. indicator.

Clipsal has a 12 Volt indicator available which is 30N12 available with Amber, Blue, Green or Red indication. See Figure 4 below.

The 30PBBP and 30N12 will fit into a two gang wall plate 32VH.

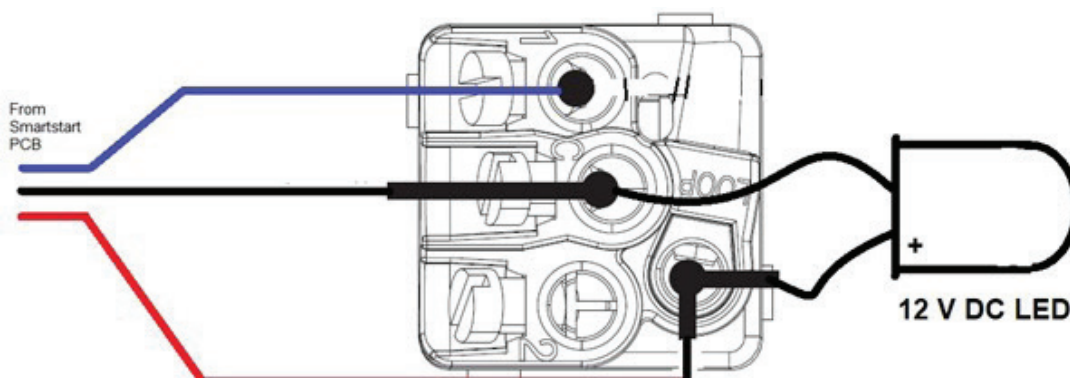



Figure 4. Clipsal Switch

## GENERAL INSTALLATION INFORMATION

Neon Indicator Mechanisms		
Cat. No.	Description	
30N-RED	A	250V - neon indicator (RED)
30N-COLOUR		250V - neon indicator (Other colours)



Colours available are Blue, Green, Amber and transparent. Other voltages available, including 6, 12, 24, 32, 48, 110 and 440. Suitable for DC loads. To order, add voltage to Cat. No. (for example, 30N12). Neons draw 250-275mW at 240V. Note: Inductive loads occasionally cause neons to glow in OFF position. To prevent this place 47kΩ, 0.5W 240V resistor across the terminals. Neutral and Active can be connected to either terminal.

Standard Size Flush Plates				
Cat. No.	Length	Width	Depth	Mounting Centres
All Products	115mm	73mm	11mm	84mm apart
31VH	A	1 Gang Flush Plate		
32VH	B	2 Gang Flush Plate		
33VH	C	3 Gang Flush Plate		
34VH	D	4 Gang Flush Plate		

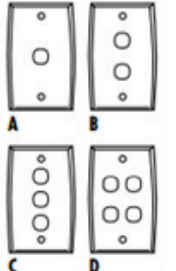

## WATER CONTROLLERS

- At least one controller must be fitted to enable activation of the Smartstart system. Up to three or four controllers can be fitted depending on water heater model. Refer to the 'WATER CONTROLLERS' section of the 'Installation Instructions' supplied with the Rinnai water heater for details.

## HEATED WATER DELIVERY TEMPERATURE



This appliance **MUST** only be installed in accordance with the acceptable plumbing configurations specified in these instructions. Failure to do so may result in conditions where delivery temperature control is inadequate.



This appliance may deliver water at high temperature. Refer to the Plumbing Code of Australia (PCA), local requirements and installation instructions to determine if additional delivery temperature control is required.

The maximum water temperature delivered at the hot water outlets is determined by the pre-set limit programmed into the water heater. Local regulations and/or the requirements of AS/NZS 3500 must be considered regarding the temperature limitations of hot water supplied to areas used primarily for personal hygiene. The temperature of water to these areas may be limited to 50°C or less. If you are unsure about local regulations, contact your regulating authority or Rinnai.

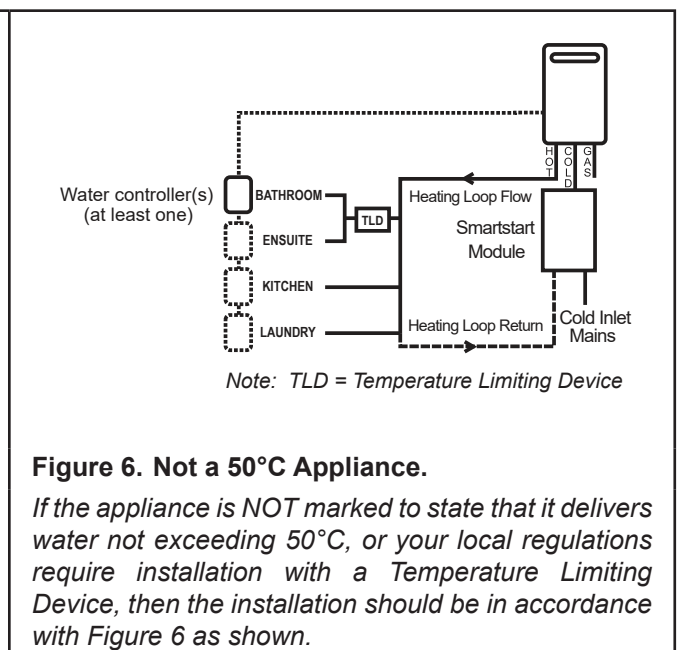
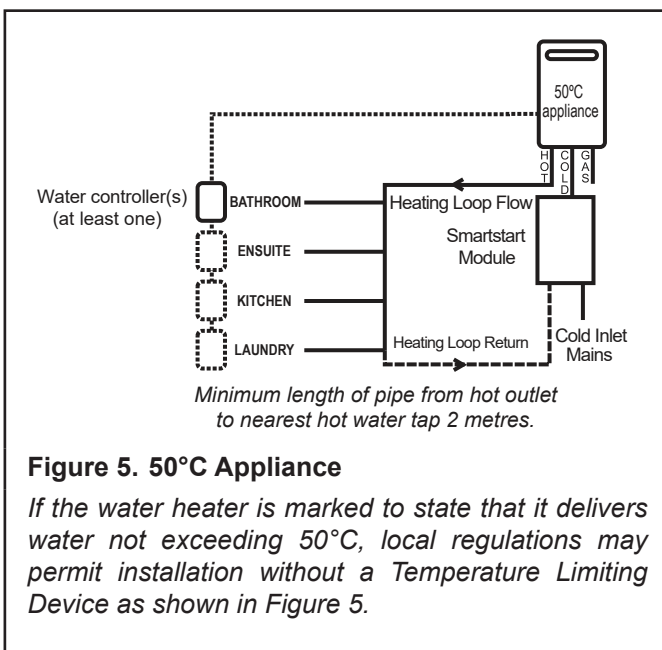

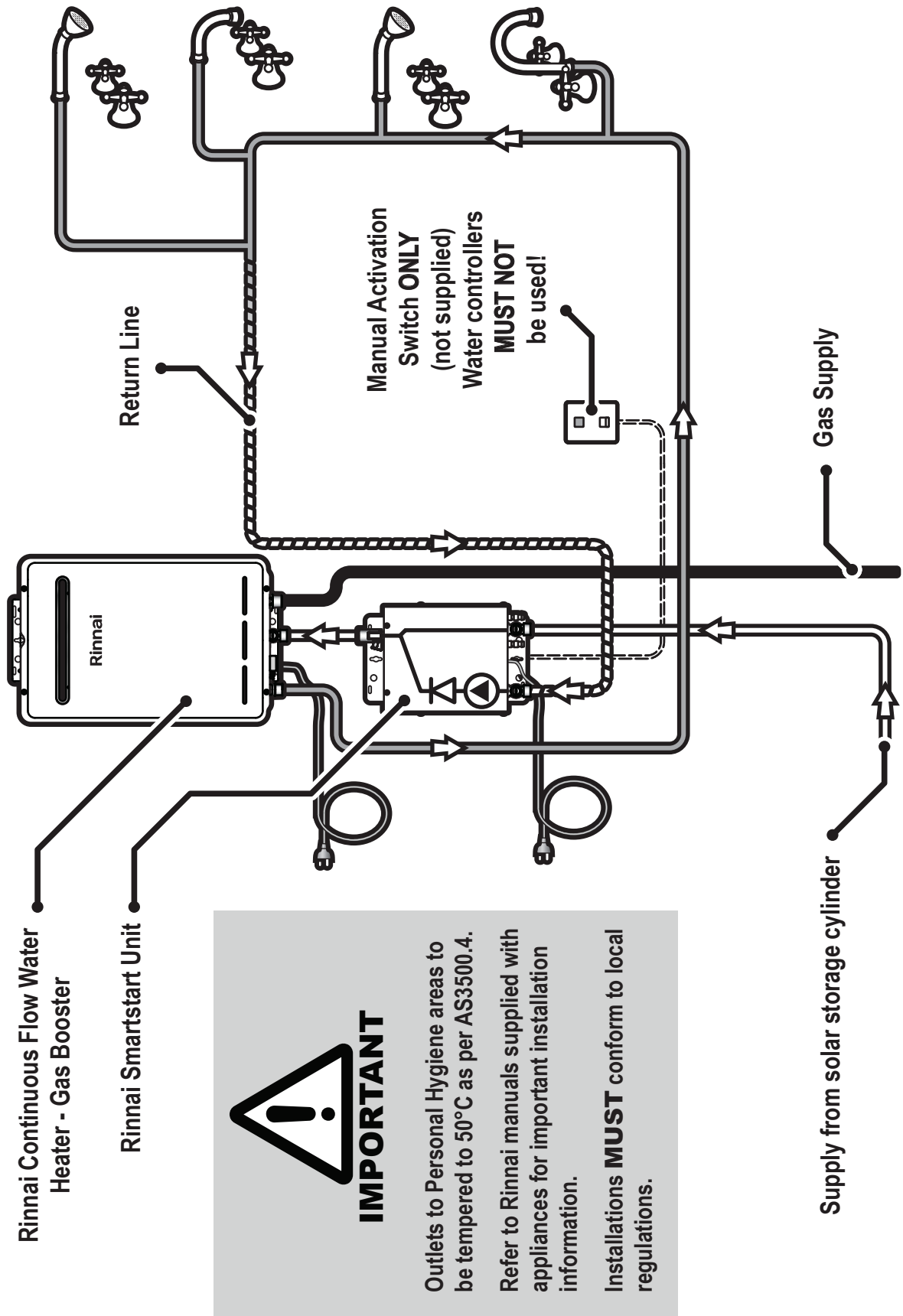

Figure 7. Solar System Connections

# COMMISSIONING

## TESTING AND COMMISSIONING

1. Ensure the power supply to the Smartstart unit is switched 'off'.
2. Carry out steps 1-12 of the 'Testing' in the Commissioning section from the 'Operation / Installation Manual' supplied with the water heater.
3. Inspect and clean the strainer located on the cold water inlet connection of the Smartstart module. This procedure may need to be repeated to ensure the strainer remains clear, especially on new installations.
4. Turn 'off' the power supply to both the water heater and Smartstart units.
5. Open all available hot water taps, including the shower, again until water from all outlets is cold. Then close the hot water taps.



Ensure building occupants **DO NOT** have access to hot water outlets during this procedure.

6. Open the Smartstart module Pump and Cold Water inlet bleed valves items ⑫ & ⑬ of Figure 3 on page 7, (actual position of 'bleed valves' is shown on dimensional drawing) until all air pockets are released and a steady stream of water is discharged.
7. Activate the power supply to both the water heater and Smartstart unit.
8. If water controllers are fitted: Press the 'on/off' button on the water control panel. The 'on' indicator next to the transfer button will glow when the control panel has been switched 'on'. Then adjust the temperature to the hottest setting by pressing the 'hotter' button until the temperature displayed on the control panel cannot be increased any further. Then press the 'preheat' button on the control panel. The 'preheat' indicator next to the preheat button will glow indicating that the preheat system has been activated.

If a manual activation switch is fitted: Press the switch once. With the Smartstart unit now activated via the water controller or manual activation switch, the pump should start running immediately afterwards which is indicated by the left LED on the Smartstart PCB glowing green continuously. Check that this is the case. If the left LED on the Smartstart PCB does not glow green the pump has not started. In this case there is probably an incorrect or missing wiring connection between water controllers or manual activation switch and the water heater or Smartstart unit. Check all wiring and connections between these items.

If the pump activates as required, shortly afterwards the water heater should turn on also. Wait two minutes. This will allow the water in the pipework to be warmed. If the water heater does not turn on re check electrical connections and installation.

9. Open the heated water outlet furthest away from the water heater. The water should become warm in a matter of seconds.



The waiting time for heated water delivery will vary depending on the size and layout of the branch line.

10. Inspect and clean the strainer located on the heating return loop inlet connection of the Smartstart module. This procedure may need to be repeated to ensure the strainer remains clear, especially on new installations.
11. Confirm the temperature delivered at the outlet with a suitable thermometer or digital temperature indicator. It should not exceed the temperature displayed on the water controller or the pre-set limit programmed into the printed circuit boards of either the Smartstart module or water heater.
12. After testing is completed, explain to the householder the functions and operation of the water heater, Water controller(s) and the Smartstart module. Explain to the householder that some temperature fluctuations may be experienced some of the time as a result of installing Smartstart.
13. Ensure the customer record section of the 'Operation / Installation manual' is filled in and that the booklet is handed to the customer.
14. The preheat function is cancelled 5 minutes after activation and the 'preheat' indicator will go out. This is to conserve energy. To reactivate, simply repeat steps 7-9 above.

**WIRING DIAGRAM**

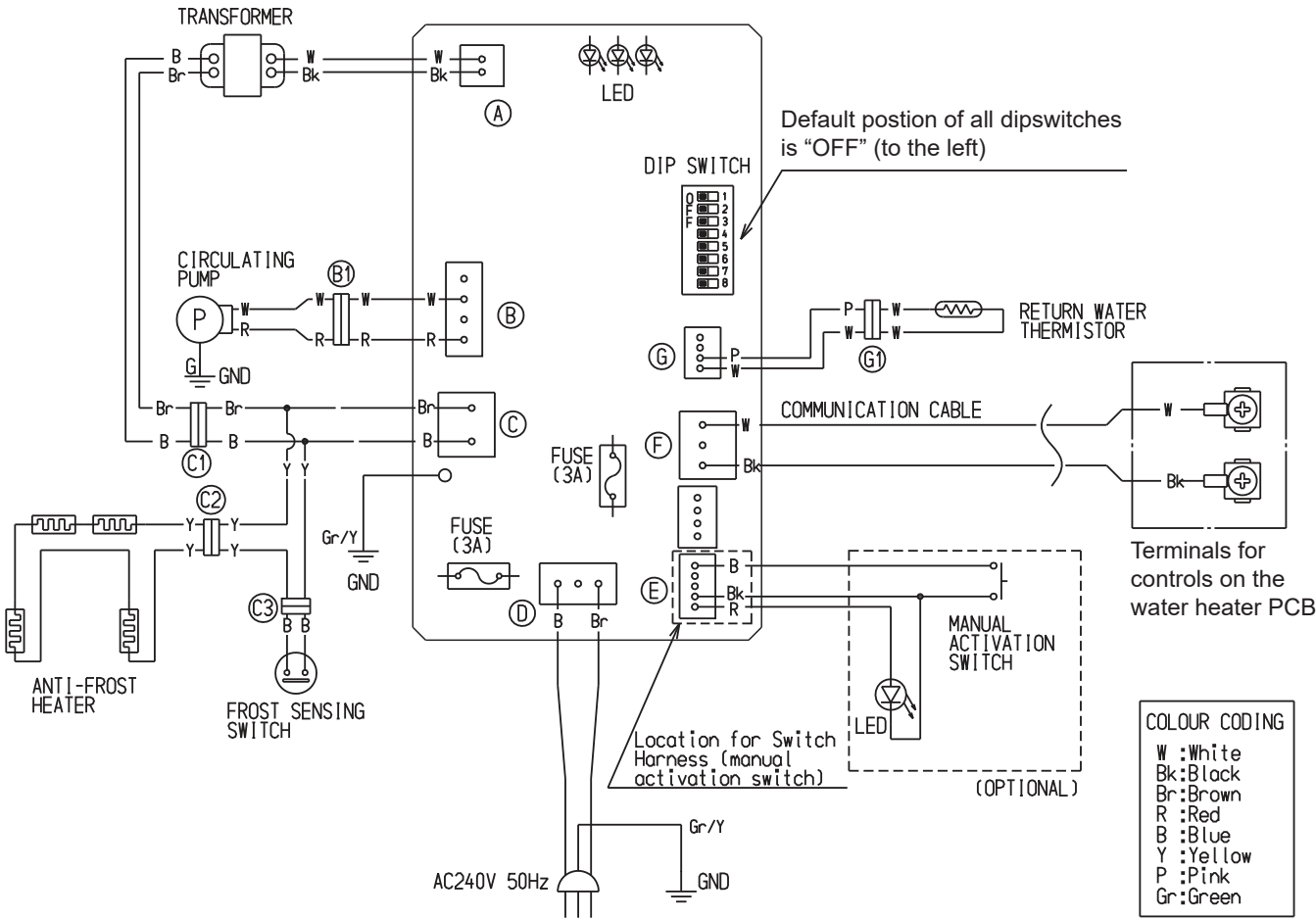

**DIMENSIONAL DRAWINGS**

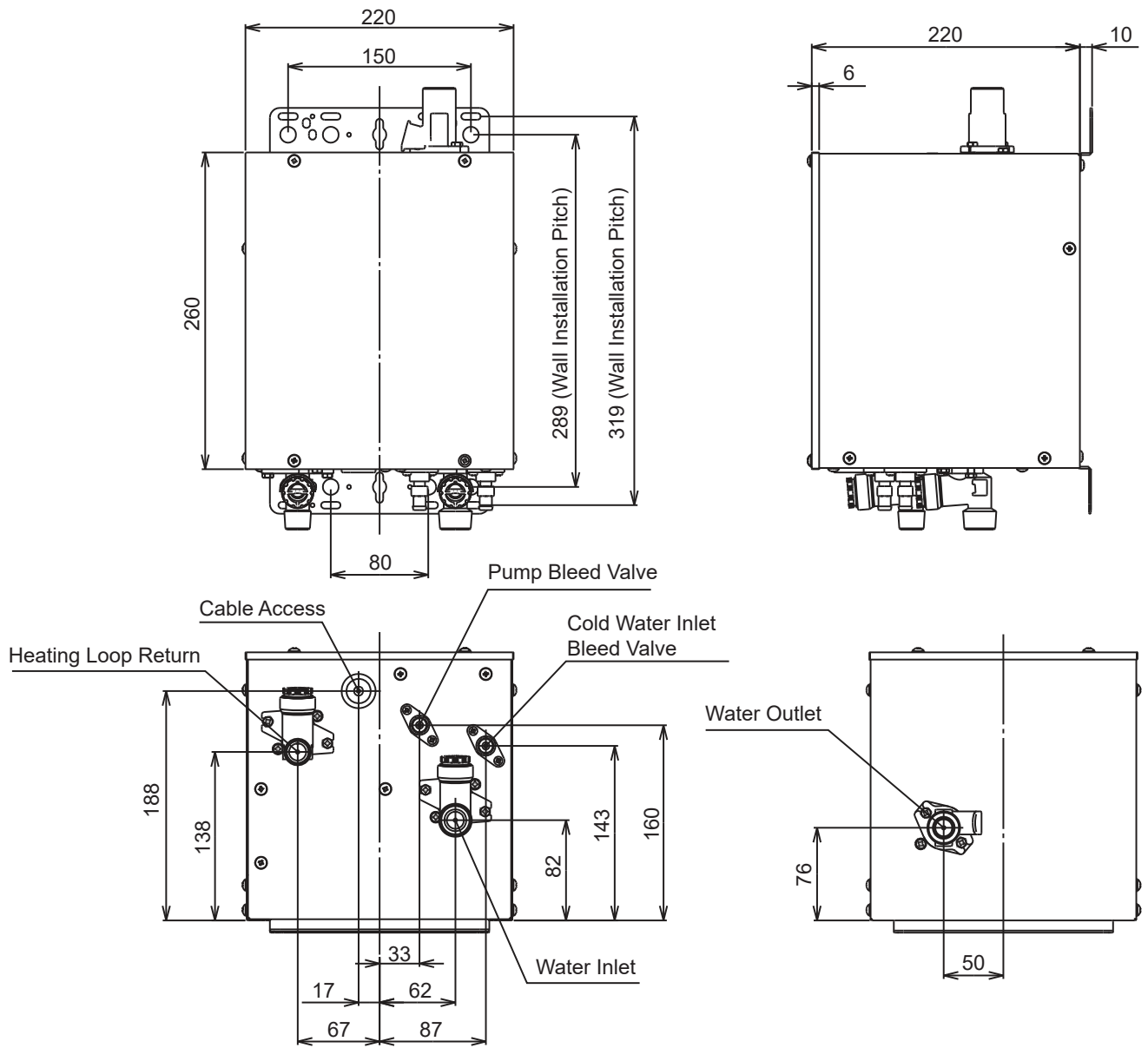



# Rinnai Australia Pty Ltd

ABN 74 005 138 769 | AU45204

100 Atlantic Drive, Keysborough, Victoria 3173  
P.O. Box 460, Braeside, Victoria 3195  
Tel: (03) 9271 6625  
Fax: (03) 9271 6622

## **National Help Line**

Tel: 1300 555 545\* Fax: 1300 555 655  
*Monday to Friday, 8.00 am to 5.00 pm EST.*

## **After Hours Hot Water Service Line**

Tel: 1800 000 340\*

*\*Cost of a local call may be higher from a mobile phone.  
(National calls from public phones in Australia are free.)*

For further information visit **[www.rinnai.com.au](http://www.rinnai.com.au)**  
or email **[enquiry@rinnai.com.au](mailto:enquiry@rinnai.com.au)**

Rinnai has a Service and Spare Parts network with personnel who are fully trained and equipped to give the best service on your Rinnai appliance. If your appliance requires service, please call our National Help Line. Rinnai recommends that commercial appliances be serviced every 1 year and that domestic appliances be serviced every 2 years.

With our policy of continuous improvement, we reserve the right to change, or discontinue at any time, specifications or designs without notice.