

MODELS

System		HSNCJ26B1		HSNCJ35B1		HSNCJ52B1		HSNCJ70B1
Indoor		HINCJ26B1		HINCJ35B1		HINCJ52B1		HINCJ70B1
Outdoor		HONCJ26B1		HONCJ35B1		HONCJ52B1		HONCJ70B1

REFRIGERANT
R32

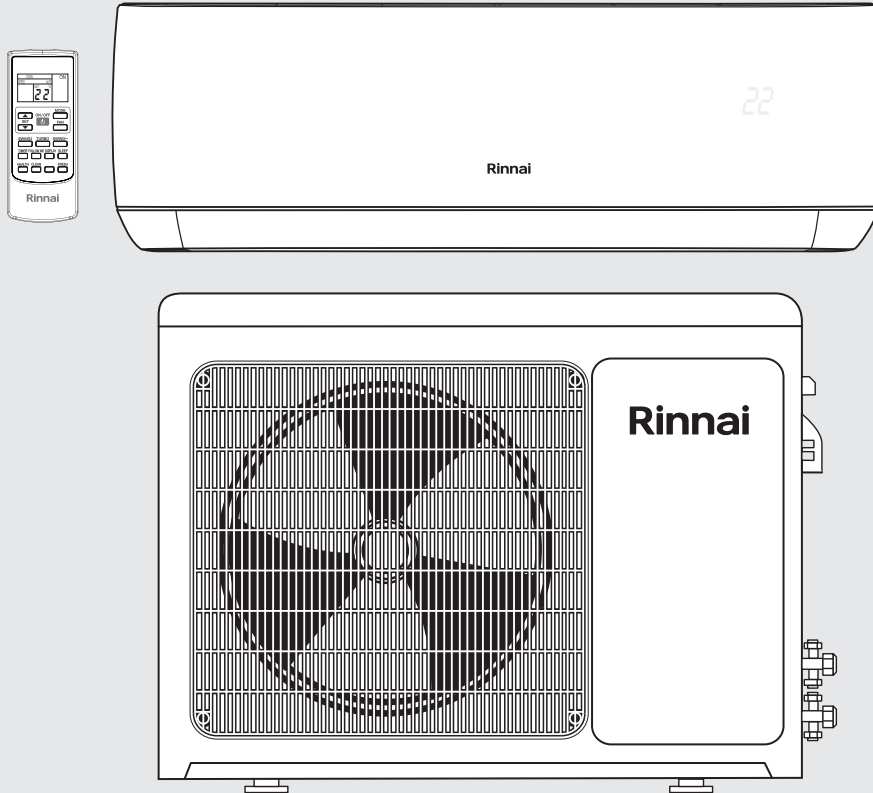

CJ1 Series Split Type Wall Mounted Air Conditioner Installation Manual

Rinnai

This appliance must be installed in accordance with:

- Manufacturer's Installation Instructions
- Current AS/NZS 3000, AS/NZS 5141
- Local Regulations and Municipal Building Codes including local OH&S requirements

This appliance must be installed, maintained and removed only by an Authorised Person.

For continued safety of this appliance it must be installed and maintained in accordance with the manufacturer's instructions.



TABLE OF CONTENTS

Warnings and Important Information	4
Installation General	7
Contents Checklist	7
Appliance Components	7
Weights & Dimensions	7
Location	8
Indoor Unit	8
Outdoor Unit	8
Pipe Length & Elevation Limits	8
Installation	9
Indoor Unit	9
Wall Mounting Plate	9
Wall Penetration	9
Drain Pipe	9
Electrical Connections	10
Wall Installation	10
Outdoor Unit	11
Electrical Connections	11
DRED Connection (optional)	12
Condensate Drain Installation	12
Refrigerant Pipes	13
Flaring	13
Connecting Vapour / Liquid Pipes To Indoor & Outdoor Units	13
Air Purging & Leakage Test	14
Evacuation Vacuum Method / Leak Test	14
Adding Refrigerant for Longer Line Length	14
Final Checklist	15
CONTACTS	16

WARNINGS AND IMPORTANT INFORMATION



READ ALL INSTRUCTIONS BEFORE USING THE APPLIANCE.

Always comply with the following precautions to avoid dangerous situations and to ensure optimum performance.

Failure to carefully read and follow all instructions in this manual can result in equipment malfunction, property damage, personal injury and/or death.

DANGER: Indicates an imminently hazardous situation which, if not avoided, will result in personal injury or death.

WARNINGS: Indicates a potentially hazardous situation which, if not avoided, could result in personal injury or death.

CAUTIONS: Indicates a potentially hazardous situation which, if not avoided, could result in minor or moderate injury or damage to the appliance. It may also be used to alert against unsafe practices.



REGULATORY

This appliance shall be installed in accordance with:

Manufacturer's Installation Instructions.

Current AS/NZS 3000, AS/NZS 5141.

Local Regulations and Municipal Building Codes including local OH&S requirements.

This appliance must be installed, maintained and removed **ONLY** by an Authorised Person.

For continued safety of this appliance it must be installed and maintained in accordance with the manufacturers instructions.

This appliance uses R32 refrigerant.

This appliance is heavy, use 2 people or mechanical lifting device. Improper lifting may result in serious injury.

Take care when opening or unpacking this appliance. Failure to do so may result in serious injury or product failure.

DO NOT modify the electrical wiring of this appliance. If the control power wiring is damaged or deteriorated then it must be replaced by an authorised person. Failure to do so may result in electric shock, fire, serious injury or product failure.

DO NOT install the air conditioner on an unstable or non level surface or where there may be a danger of it falling. It may result in death, serious injury, or product failure.

DO NOT install the outdoor unit where noise may cause nuisance.

DO NOT install the outdoor unit where it will be exposed to sea wind (salt spray) as this will reduce durability.



MANDATORY INSPECTION PRIOR TO INSTALLATION

Immediately report any damage or discrepancies to the Supplier of the appliance. This appliance was inspected and tested at the time of manufacture and packaging, and released for transportation without known damage. Upon receipt, inspect the exterior for evidence of rough handling in shipment. Ensure that the appliance is labelled correctly for the gas and electrical supply, and/or other services it is intended to be connected to.

For safety and warranty purposes, appliances that may be damaged or incorrect **MUST NOT** be installed or operated under any circumstances. Installation of damaged or incorrect appliances may contravene local government regulations. Rinnai disclaims any liability or responsibility whatsoever in relation to the installation or operation of damaged or incorrect appliances.



INSTALLATION

This appliance shall be installed in accordance with local electrical safety regulations by an authorised person such as a licensed electrician.

This appliance is a Type 1 Electrical Appliance.

Make sure the live wire, neutral wire and earth wire in the power socket are properly connected. Inadequate or incorrect electrical connections may cause fire or electric shock.

The yellow-green wire in air conditioner is the earthing wire which cannot be used for other purposes. Improper earthing may cause electric shock.

The circuit breaker must have the functions of magnetic tripping and heat tripping to prevent short circuit and overload.

Use a standard circuit breaker and fuse conforming with the rating of the appliances.

Model	HSNCJ26B1	HSNCJ35B1	HSNCJ52B1	HSNCJ70B1
Circuit Breaker (Amps)	16	16	16	20

The unit must be earthed in accordance with local regulations.

Connect all wiring tightly. Failure to do so may result in electric shock or product failure.

DO NOT supply power to the unit until all wiring and tubing are completed.

Select an installation location where the components can be mounted securely and accessible for service and replacement.

Make sure tubing is properly insulated to ensure optimum performance.

Install the drain hose properly for smooth drainage of condensed water.

Make sure to check for and rectify any refrigerant leaks after you install or repair the unit.

This appliance uses R32 (difluoromethane) refrigerant, which is a flammable gas class 2.2 according to AS/NZS 1677 and must be handled by a refrigeration mechanic with appropriate Australian refrigerant handling licence.



WARNING Risk of fire / flammable material. If the refrigerant is leaked, together with an external ignition source, there is a possibility of ignition.



Read the OPERATING INSTRUCTIONS carefully before operation.



Service personnel are required to carefully read the OPERATING INSTRUCTIONS and INSTALLATION MANUAL before operation.



Further information is available in the OPERATING INSTRUCTIONS, INSTALLATION MANUAL, and the like.

Certain levels of refrigerant require minimum room sizes. Please ensure that these minimum room sizes are adhered to for standard installations (up to 10m pipe length). If larger refrigerant charges than standard are used then please consult AS/NZS 60335.2.40 to determine the safe minimum floor area for the installation.

Make sure that the area has been made safe by having suitable ventilation and is free from ignition sources before charging or releasing the charge of R32.

Model	HSNCJ26B1	HSNCJ35B1	HSNCJ52B1	HSNCJ70B1
Standard Charge (g)	660	1000	1200	1350
Minimum Floor Area (m ²)	1.00	1.00	1.74	1.74



OPERATION

DO NOT let the air conditioner run for extended periods when the humidity is very high or when doors or windows are left open. As this may result in an excessive operational loading and lead to product failure.

DO NOT cover or place articles on any part of this appliance.

DO NOT touch, operate or clean the air conditioner with wet hands. It may result in electric shock or product failure.

DO NOT insert hands or other objects through the air inlet or outlet while the appliance is operating. It may result in electric shock or product failure.

DO NOT place a heater or other heating appliances near this appliance, always ensure sufficient ventilation when using this appliance and a heating appliance at the same time. Failure to do so may result in product mis-operation.

Turn main power off before cleaning. Failure to do so may result in fire, electric shock, or product failure.

DO NOT use solvents, abrasives or harsh detergent to clean any part or surface of this appliance or spray water or allow liquids to enter the indoor unit. The enclosure of the appliance and remote control can be cleaned using a soft, damp cloth and a mild detergent.

NEVER touch the metal parts of the air conditioner when you remove the air filter. It may result in electric shock or product failure.

DO NOT leave flammable materials near the appliance. It may result in explosion or fire.

If there is excessive noise, smell or smoke coming from the appliance, turn the appliance off, isolate the power supply and contact a service agent.

DO NOT operate the appliance if it has been submerged into water due to flooding, contact a service agent. Failure to do so may result in electric shock, fire, serious injury, or product failure.

This appliance is not intended for use by persons (including children) with reduced physical, sensory or mental capabilities, or lack of experience and knowledge unless they have been given supervision or instruction concerning use of the appliance by a person responsible for their safety.

Children should be supervised to ensure that they **DO NOT** play with the appliance.

The air conditioning system is designed to achieve consumer comfort. It is **NOT** designed for commercial applications requiring a controlled atmosphere (i.e. computer rooms, food preservation, etc.)

DO NOT block the inlet or outlet of air flow. It may result product in failure.

DO NOT drink the condensate water drained from the appliance. This condensate is not potable and may present a health risk if consumed.

DO NOT expose people, animals or plants directly to the cold or hot discharge of the appliance. It may result in serious injury.

DO NOT mix the batteries for the remote control with other types of batteries or mix new batteries with used batteries. Failure to do so may result in product failure. **STOP** using the remote control if there is a battery fluid leak.

OPERATION RANGE LIMITATIONS

The table below indicates the temperature ranges the air conditioner can be operated within.

MODE	Cool Mode	Dry Mode
Room Temperature	> 17°C	> 17°C
Outdoor Temperature	-15°C ~ 52°C	-15°C ~ 52°C

INSTALLATION GENERAL

CONTENTS CHECKLIST

Item and quantity provided							
Indoor unit	x1	Indoor unit support bracket	x1	Drain pipe	x1	Putty	x1
Remote controller	x1	Outdoor unit	x1	Brass nut (small)	x2	Operation manual	x1
Remote control wall bracket	x1	Rubber vibration damper	x4	Brass nut (large)	x2	Installation manual	x1
AAA battery	x2	Drain plug	x1	Tape	x1	Energy label	x1

APPLIANCE COMPONENTS

- Indoor unit air inlet
- Filter (located behind front access panel)
- Manual ON/OFF (Auto) override button (located behind front access panel)
- Indoor unit air outlet (with louvres and vanes for setting air flow direction)
- Remote control
- Signal receiver window and temperature display (the display is built into the front access panel)
- Refrigerant pipes, electrical cable(s) (covered with binding tape)
- Condensate drain hose (covered with binding tape)
- Refrigerant entry (for service and installer use only)
- Outdoor unit air inlet (on rear & left side of unit)
- Outdoor unit air discharge and protective grille (on front of unit)

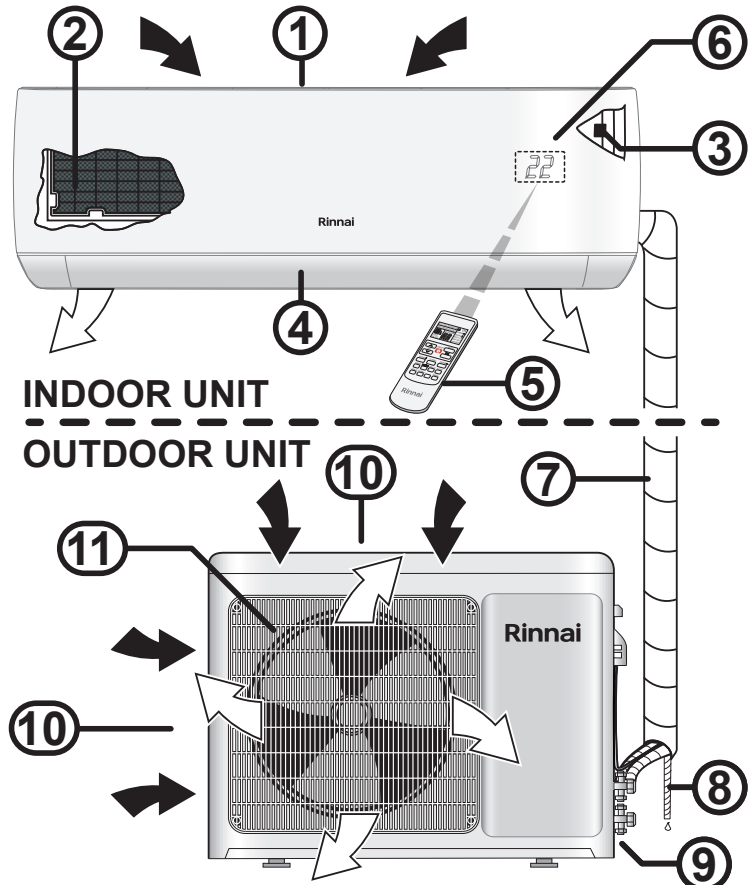

WEIGHTS & DIMENSIONS

Model		HSNCJ26B1			HSNCJ35B1			HSNCJ52B1			HSNCJ70B1		
Weight (kg)	Indoor	9.5			12.0			13.5			14.0		
	Outdoor	28.0			30.5			47.0			48.0		
Dimensions (mm)	Indoor	A	B	C	A	B	C	A	B	C	A	B	C
		881	194	294	940	224	316	997	227	316	1132	232	330
	Outdoor	D	E	F	D	E	F	D	E	F	D	E	F
800		50	545	800	50	545	900	50	700	900	50	700	
		G	H	I	G	H	I	G	H	I	G	H	I
		353	545	315	353	545	315	388	630	350	388	630	350

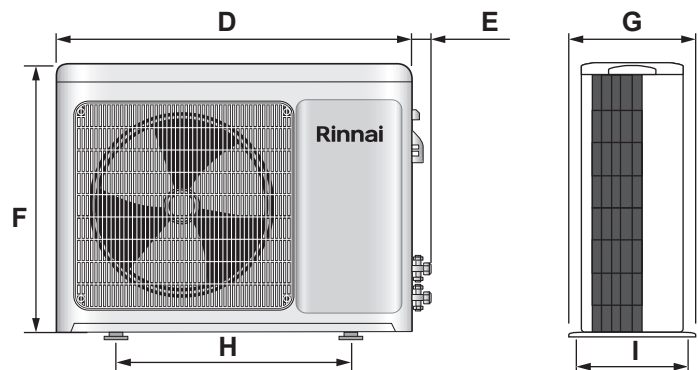
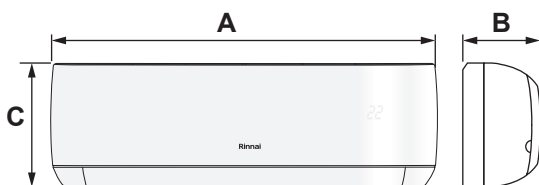

LOCATION

INDOOR UNIT

- Ensure the indoor unit is located away from heat or steam.
- Ensure the indoor unit is located so it can be accessed for service and replacement.
- Ensure the indoor unit is located so condensate can be drained away.
- Select a location where the indoor unit can be securely mounted.
- The clearances shown **MUST BE** maintained.

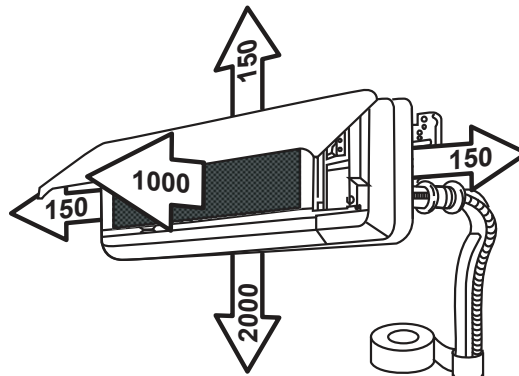

OUTDOOR UNIT

- Select the location where exposure to direct sunlight and strong wind are minimised.
- Select the location where the outdoor unit can be securely mounted.
- Select the location where the noise and air flow will not cause nuisance.
- Ensure there are no obstructions in the air flow path.
- Ensure the outdoor unit is located so it can be accessed for service and replacement.
- Do not place animals and plants near the air discharge.
- The clearances shown **MUST BE** maintained.

(All dimensions in mm)

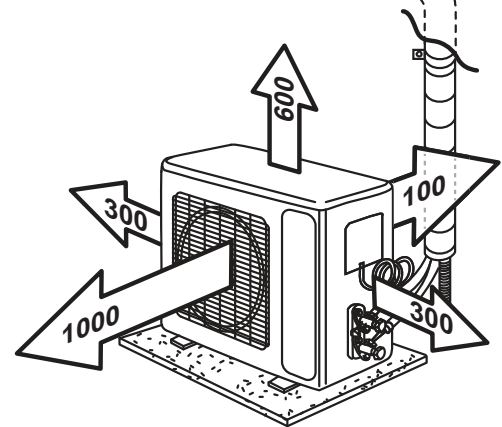

PIPE LENGTH & ELEVATION LIMITS

Models	Pipe Size Gas		Pipe Size Liquid		Chargeless Length m	Minimum Length - X m	Maximum Length - X m	Maximum Height - Y m	Additional Refrigerant g/m
	mm	inch	mm	inch					
HSNCJ26B1	Ø9.52	3/8	Ø6.35	1/4	10	2	20	12	15
HSNCJ35B1	Ø12.7	1/2	Ø6.35	1/4	10	2	20	12	15
HSNCJ52B1	Ø12.2	1/2	Ø6.35	1/4	10	2	30	20	15
HSNCJ70B1	Ø15.88	5/8	Ø6.35	1/4	10	2	30	20	15



The outdoor unit is supplied already charged for interconnecting pipe lengths of 2 metres up to 10 metres in length.

Removal of refrigerant is necessary if pipe length is less than 2 metres and additional refrigerant will be required for pipe lengths in excess of 10 metres. (Please refer to the above table.) Removal or addition of refrigerant must be by best practice.

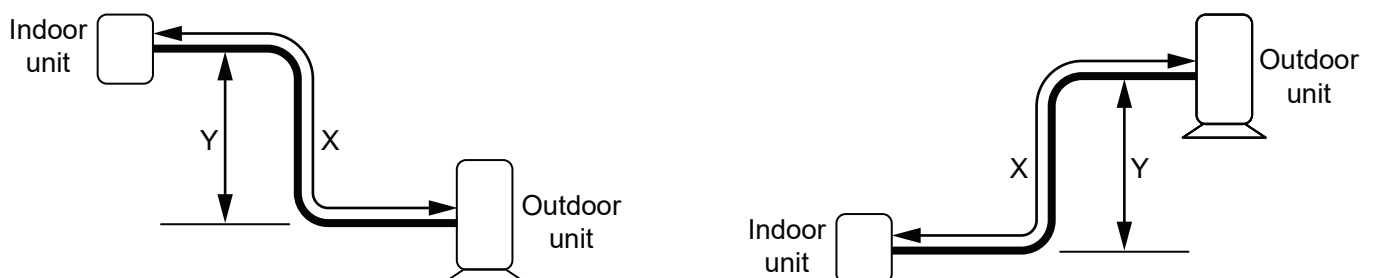

INSTALLATION

INDOOR UNIT

Wall Mounting Plate

1. The wall or structure on which the units are to be mounted must be capable of supporting the weight of the appliance and the associated pipe-work.
2. Fix the mounting plate on to the wall using, ensuring that it is both level and firmly mounted with the appropriate fixings.



DO NOT install the unit in a place where electrical wiring or conduits are located.

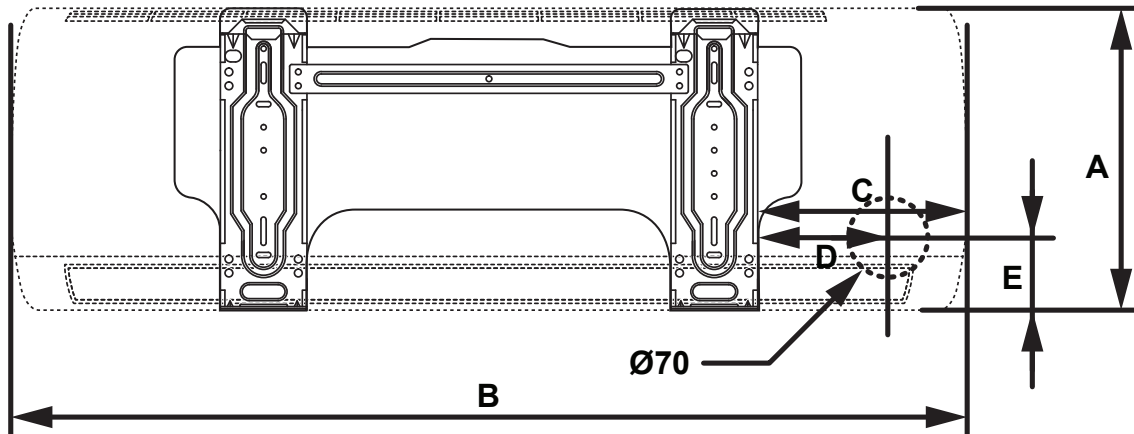

Wall Mounting Plate Positioning Dimensions (mm)

HINCJ26B1					HINCJ35B1					HINCJ52B1					HINCJ70B1				
A	B	C	D	E	A	B	C	D	E	A	B	C	D	E	A	B	C	D	E
294	881	228	84	43	316	940	218	54	41	316	997	217	43	38	330	1132	236	56	39

Wall Penetration

Drill a Ø70mm wall penetration through the wall with a 2° to 4° fall to the outside wall.

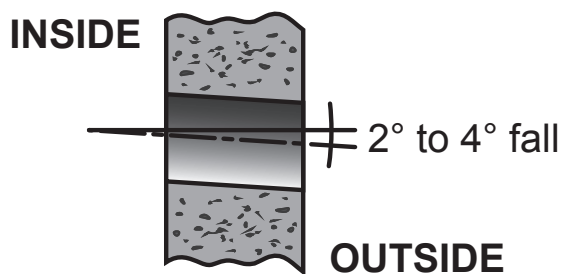

Drain Pipe

1. Connect the drain pipe to the drain hose outlet of the indoor unit,
2. Bind the joint with PVC insulation tape (not supplied).

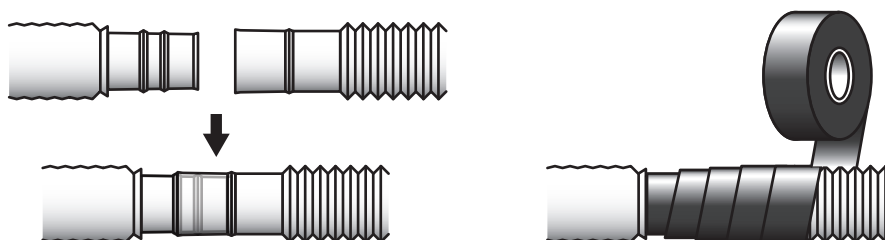

INSTALLATION

Electrical Connections



Must be installed, maintained and removed by authorised persons in accordance with AS/NZS 3000 and all other relevant local regulations and municipal building codes including OH&S requirements.

Ensure electric wiring is installed properly. Improper installation may cause malfunction, fire, or electric shock.

The unit must be earthed following local electrical codes.

1. Open the front panel.
2. Remove the wiring cover.
3. Insert the electrical cable(s) through the bottom side at the back of indoor unit.
4. Secure the cable onto the control board with the cable clip.
5. Connect the cables as shown on the drawing to the corresponding terminals.
6. Re-install the wiring cover.
7. Close the front panel.

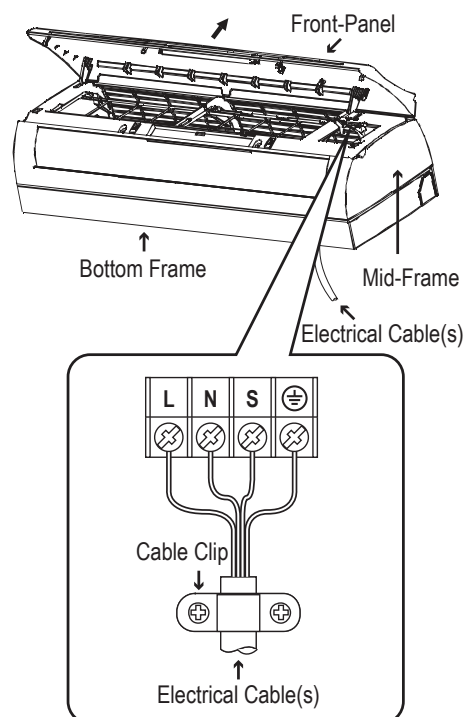

Wall Installation

1. Remove the two foam shipping blocks from the rear of indoor unit as shown.
2. Position the piping as shown on the drawing.
3. Tape the refrigerant pipes, electric cable(s) and drain hose. Ensure the water drain hose is located at the lowest side of the bundle.

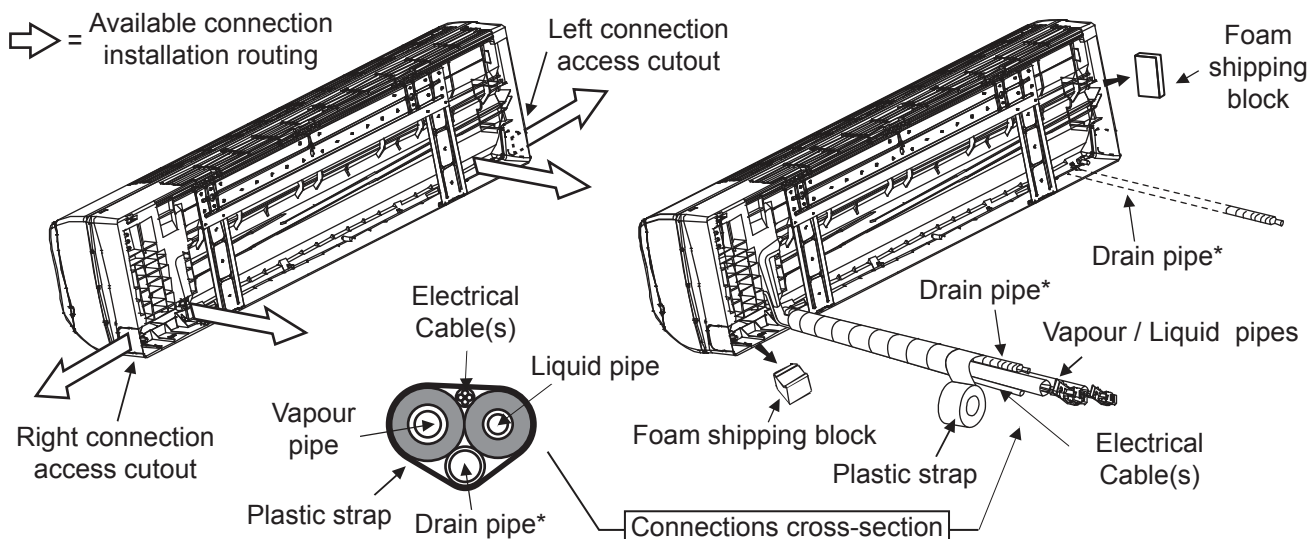

* The drain pipe is dual handed and may be installed to either the left or right of the appliance.

1. To use this option unclasp the drain hose.
2. Unscrew the rubber plug from the alternate drainage discharge connection point.
3. Clip the drainage hose into the alternate discharge connection point.
4. Screw the rubber plug into the unused drainage discharge connection point.

4. Hang the mounting slots of the indoor unit on the upper portion of the mounting plate. Ensure that the hooks are properly seated on the plate.
5. Push the unit towards to the wall, and hook the unit onto the lower fixing hook.

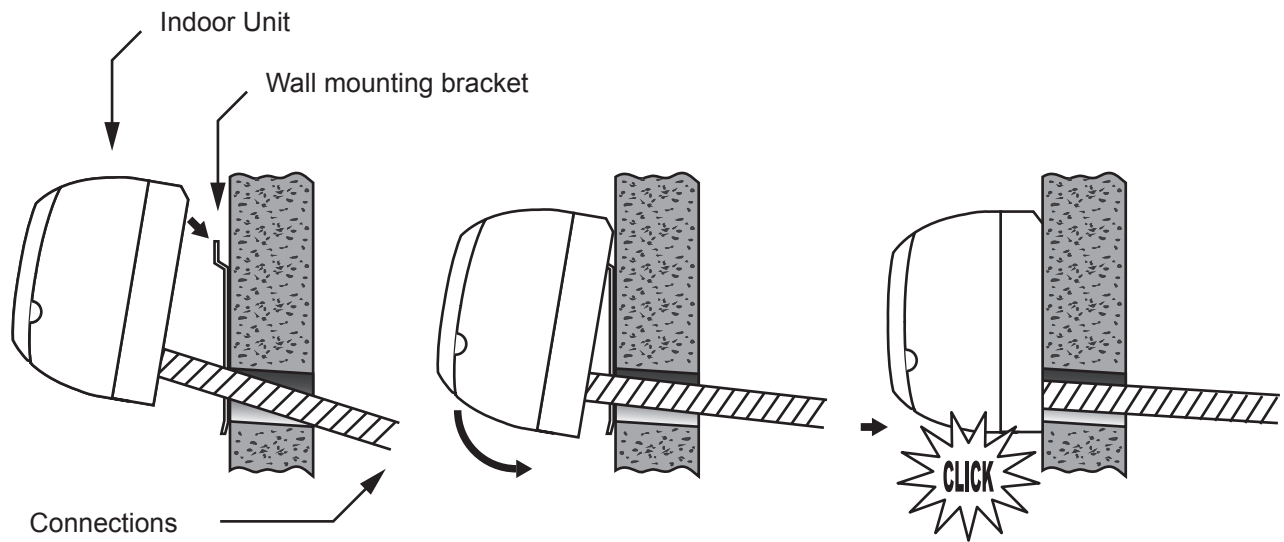

Ensure that there is no leakage from the drain pipe connection and that the drain pipe has a continuous fall to the outside.

Ensure that all wall penetrations are sufficiently weatherproofed.

OUTDOOR UNIT

Electrical Connections



Must be installed, maintained and removed by authorised persons in accordance with AS/NZS 3000 and to all other relevant local regulations and municipal building codes including OH&S requirements.

Ensure electric wiring is installed properly. Improper installation may cause malfunction, fire, or electric shock.

The unit must be earthed following local electrical codes.

1. Remove the wiring cover.
2. Secure the electrical cable(s) and power cable onto the control board with the cable clip.
3. Connect the cables as shown on the drawing below.

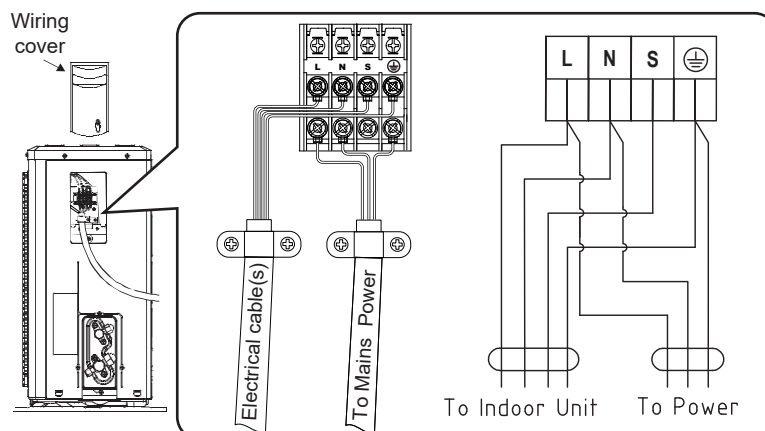

4. Re-install the wiring cover.

INSTALLATION

DRED Connection (optional)

This appliance is supplied with an DRED interface, the interface provides two connection methods of either a four wire terminal connection or an RJ45 socket.



Must be installed, maintained and removed by authorised persons in accordance with AS/NZS 3000 and to all other relevant local regulations and municipal building codes including OH&S requirements.

Ensure electric wiring is installed properly. Improper installation may cause malfunction, fire, or electric shock.

1. Remove the wiring cover.
2. Connect the power feed to the terminal block as shown on the drawing below.
3. Connect the communication cable to DRED interface using either the four wire terminal connections or RJ45 socket provided.

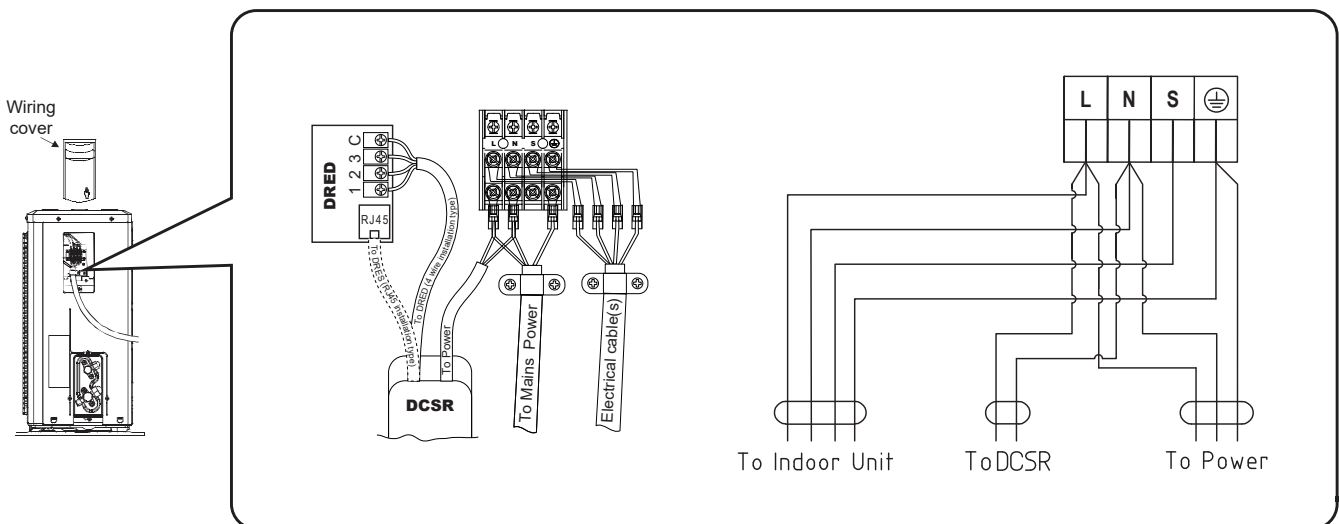

4. Re-install the wiring cover.

CONDENSATE DRAIN INSTALLATION

A condensate drainage point is provided in the base of the outdoor unit.

For the purposes of drainage a barbed elbow is also supplied.

Insert the barbed elbow into the drainage point of the outdoor unit as shown.

A drainage hose (installer to supply) will need to be fitted.



Drainage of the condensate must conform with all local regulations and municipal building codes including local OH&S requirements.

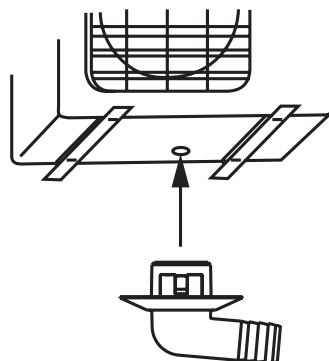

REFRIGERANT PIPES

Flaring



- The main cause for refrigerant leakage is due to defects with the flaring work.
- The installer must ensure that all piping used complies with both:
AS/NZS 1571:1995 - Copper - Seamless tubes for air conditioning and refrigeration.
AS/NZS 4041:2006 - Pressure piping.
- All pipework and fittings should be thoroughly examined for cleanliness and suitability for the system and refrigerant prior to assembling.
- All unsealed tubing must be thoroughly inspected and, if necessary, cleaned before assembly to remove any copper residue and/or scale particles such as dirt or metal.
- Metal filings must not be left in pipework after cutting as they can cause damage compressor (i.e. shaft seals, bearings, etc.).
- Prior to assembly, refrigeration pipes must be clean and burr free. They must not be crushed or kinked.
- For flare connections, a suitable lubricant must be used between the back of the flare and the nut to avoid tearing the flare when tightening the nut.

Connecting Vapour / Liquid Pipes To Indoor & Outdoor Units

1. Align the centre of the pipes.
2. Sufficiently tighten the flare nut with fingers, then tighten with a spanner and torque wrench.



To prevent heat loss and wet floors due to dripping of condensation, both pipes must be properly insulated.

Pipe Dimensions (Ø)		Torque Wrench Setting
Metric	Imperial	
Ø 6.35 mm	Ø 1/4"	18 Nm
Ø 9.52 mm	Ø 3/8"	42 Nm
Ø 12.7 mm	Ø 1/2"	55 Nm
Ø 15.88 mm	Ø 5/8"	75 Nm

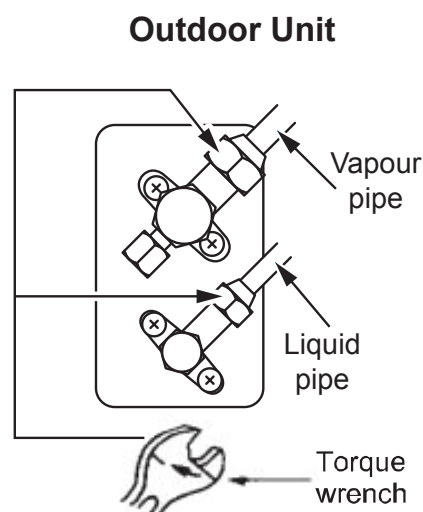
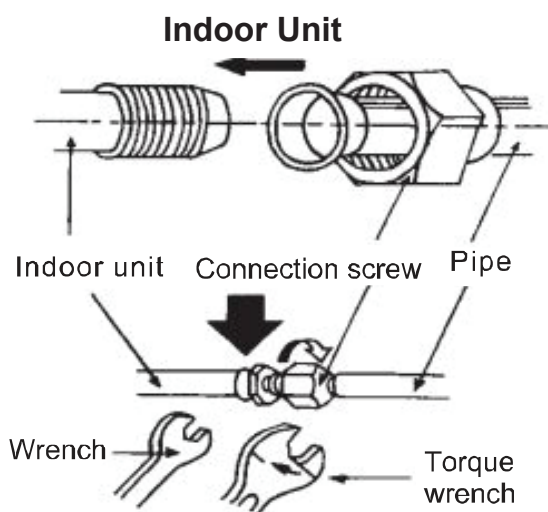

Ensure the joint nut is tightened firmly to avoid leakage.
Ensure that both the connections and the refrigerant pipes are wrapped with insulation material.

Air Purging & Leakage Test



DO NOT mix any substance other than the specified refrigerant (R32) into refrigerant system.

When refrigerant gas leaks occur, ventilate the room immediately.

R32, as well as other refrigerants, should always be recovered and never be released directly into the environment.

Use a vacuum pump for R32 exclusively. Using the same vacuum pump for different refrigerants may damage the vacuum pump or the unit.



It is necessary to purge air and check for gas leakage after piping work is completed.

If using additional refrigerant, perform air purging from the refrigerant pipes and indoor unit using a vacuum pump, then charge additional refrigerant.

Use a hex socket (3/16") to operate the service valves.

All refrigerant pipe joints to be tightened with a torque wrench at the specified torque.

Evacuation Vacuum Method / Leak Test

1. Remove the caps from the vapour valve, vapour valve service port and the liquid valve.
2. Connect charge hose from the low pressure gauge (manifold gauge set) to the vapour valve service port.
3. Open the low pressure gauge valve (manifold gauge set), turn on the vacuum pump and run for a minimum of 15 minutes.
4. Close low pressure gauge valve (manifold gauge set) and turn off vacuum pump.
5. Wait 2 minutes to allow pressure to stabilise, then check that the low pressure gauge is maintaining a pressure of -100 kPa (-76 cmHg).
6. Disconnect charge hose from the vapour valve service port and replace the vapour valve service port cap.
7. Open both the vapour and the liquid valves to charge the refrigerant system for test running.
8. Test run the system through both heating and cooling cycles and test for leaks.
9. Replace the vapour and liquid valve caps.



Both the vapour and liquid valve caps MUST BE on tight.

10. The system is now ready to run.

Adding Refrigerant for Longer Line Length

Additional refrigerant for longer piping runs can be added either at the time of evacuation of the new installation or whilst the unit is operating, see "Pipe Length & Elevation Limits" on page 8.



It is very easy to overcharge, take caution in charging refrigerant liquid and keep your eye on the scales to avoid overcharging the unit.

Take care not to discharge refrigerant into the atmosphere during installation, re-installation, repair or service.

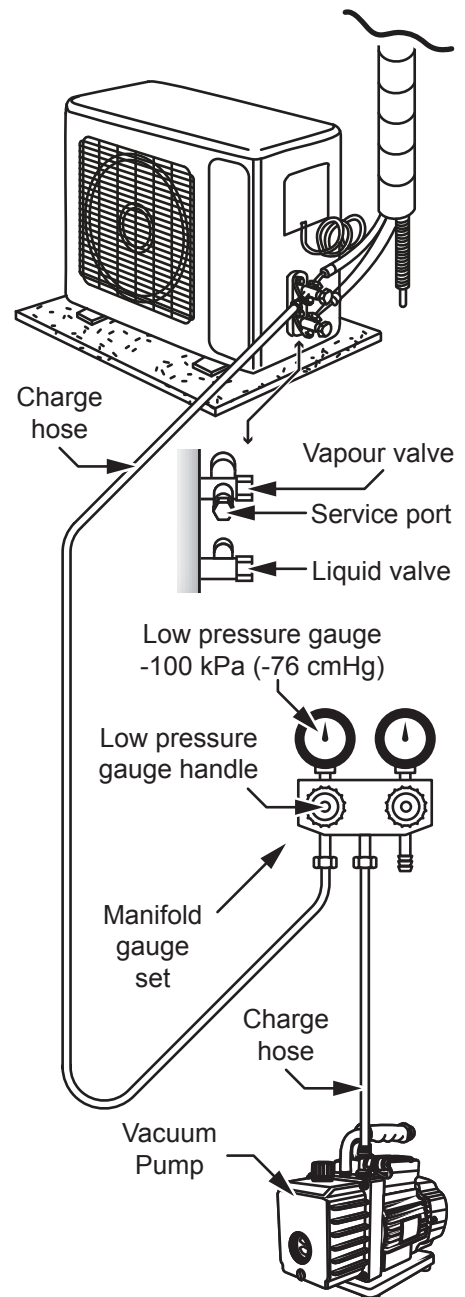

FINAL CHECKLIST



The checklist is **ONLY** to be completed by an **Authorised Person**.

Check Item	✓	What can happen if not checked
Is the indoor unit installed securely?	<input type="checkbox"/>	Falling, vibration, noise
Has an inspection been made to check for gas leakage?	<input type="checkbox"/>	No cooling or heating
Has all thermal insulation been completed (vapour pipes, liquid pipes, indoor portions of the drain hose extension)?	<input type="checkbox"/>	Condensation
Is the drainage secure?	<input type="checkbox"/>	Water leakage
Are the electric wires installed correctly?	<input type="checkbox"/>	No cooling or heating, may cause electrical shock or electrical fire.
Is the wiring in accordance within the specifications?	<input type="checkbox"/>	Operation failure, electrical fire
Are all inlets / outlets of the indoor and outdoor units free of any obstructions?	<input type="checkbox"/>	No cooling or heating
Are the stop valves open?	<input type="checkbox"/>	No cooling or heating
Are the pipes designed for use with R32?	<input type="checkbox"/>	Pipe or pipe connection leakage
Has a leak test been carried out for the pipe connections?	<input type="checkbox"/>	Pipe connection leakage
Has air purging been carried out?	<input type="checkbox"/>	No cooling or heating
Has the appliance been tested for correct operation?	<input type="checkbox"/>	No cooling or heating
Is the end user fully aware of the operating procedure?	<input type="checkbox"/>	Incorrect operation

If you have answered no to any of the above, you must check and correct before appliance hand-over to customer.

Rinnai Australia Pty Ltd

ABN 74 005 138 769 | AU45204

100 Atlantic Drive, Keysborough, Victoria 3173
P.O. Box 460, Braeside, Victoria 3195
Tel: (03) 9271 6625

National Help Line

Tel: 1300 555 545*

Monday to Friday, 8.00 am to 5.00 pm EST.

**Cost of a local call may be higher from a mobile phone.
(National calls from public phones in Australia are free.)*

For further information visit **www.rinnai.com.au**
or email **enquiry@rinnai.com.au**

Rinnai has a Service and Spare Parts network with personnel who are fully trained and equipped to give the best service on your Rinnai appliance. If your appliance requires service, please call our National Help Line. Rinnai recommends that this appliance be serviced every 2 years.

With our policy of continuous improvement, we reserve the right to change, or discontinue at any time, specifications or designs without notice.