

MODELS – Rinnai Inverter Multi Split System

Outdoor	Indoor Hi-Wall	Indoor Ducted	Indoor Cassette	Indoor Console
MON3H07B	HINRP20MB	DINSD26MB	CIN020RMB	FINRP50MB
MON4H09B	HINRP26MB	DINSD35MB	CIN026RMB	
MON5H11B	HINRP35MB	DINSD50MB	CIN035RMB	
MON5H13B	HINRP50MB	DINSD70MB	CIN050RMB	
MON6H18B	HINRP60MB HINRP70MB HINRP80MB			

REFRIGERANT
R32

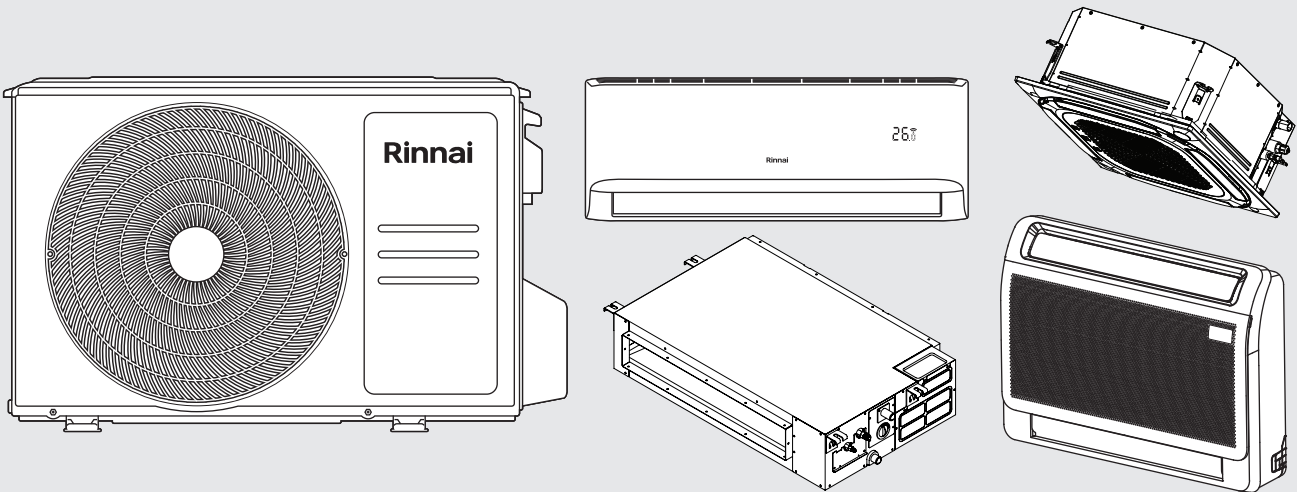

Multi Split Type Air Conditioner

Operation Manual

Rinnai



Read this manual and SAFETY MANUAL (if any) carefully before installing or operating your new air conditioning unit. Make sure to save this manual for future reference.

Please check the applicable models, technical data and manufacturer information from the “Operation Manual” in the packaging of the outdoor unit.

This appliance must be installed in accordance with:

- Manufacturer’s Installation Instructions
- Current AS/NZS 3000, AS/NZS 5149, AS/NZS 5141
- Local Regulations and Municipal Building Codes including local OH&S requirements

This appliance must be installed, maintained and removed only by an Authorised Person.

For continued safety of this appliance it must be installed and maintained in accordance with the manufacturer’s instructions.



The design and specifications are subject to change without prior notice for product improvement. Consult with the Dealer or manufacturer for details.

Any updates to the manual will be uploaded to the service website, please check for the latest version.

TABLE OF CONTENTS

Warnings and Important Information	4
Safety Precautions	7
Operation	9
Unit Parts and Major Functions	9
Operating Temperature	11
Features	12
Energy Saving Tips	13
Manual Operation – Mode Selection	14
Optimal Operation	14
Care & Maintenance	15
Cleaning the Indoor Unit	15
Cleaning the Air Filter (Wall Mounted Units)	15
Cleaning the Outdoor Unit	16
General Maintenance	16
Installation Record - Installer Details	17
Installation Record - System Details	17
Customer Care Program	17
Service Maintenance Schedule - Non Ducted Air Conditioning Systems	18
Service Maintenance Schedule - Ducted Air Conditioning Systems	19
Save a Service Call	20
Troubleshooting Tips	21
When to Call for Service	22
Disposal Guidelines	22
Contacts	28



PLEASE REFER TO ANY OPERATING MANUALS AND USER OPERATING GUIDES ACCOMPANYING ANCILLARY EQUIPMENT (WHERE FITTED)

WARNINGS AND IMPORTANT INFORMATION



READ ALL INSTRUCTIONS BEFORE USING THE APPLIANCE

Always comply with the following precautions to avoid dangerous situations and to ensure optimum performance.

Failure to carefully read and follow all instructions in this manual can result in equipment malfunction, property damage, personal injury and/or death.

WARNINGS: WHEN IGNORED, CAN RESULT IN SERIOUS INJURY OR DEATH.

CAUTIONS: WHEN IGNORED, CAN RESULT IN MINOR INJURY OR PRODUCT DAMAGE.



REGULATORY / INSTALLATION

This appliance shall be installed in accordance with:

- Manufacturer's Installation Instructions.
- Current AS/NZS 3000, AS/NZS 5141, AS/NZS 5149, AS/NZS 3500 National Plumbing & Drainage, HB276 - A Guide to good practice for energy efficient installation.
- Local Regulations and Municipal Building Codes including local OH&S requirements.
- This appliance **MUST** be installed, maintained and removed by an Authorised Person.

For continued safety of this appliance it **MUST** be installed and maintained in accordance with the manufacturers instructions.

This appliance uses R32 refrigerant.

This appliance is heavy, use 2 people or mechanical lifting device. Improper lifting may result in serious injury.

Take care when opening or unpacking this appliance. Failure to do so may result in serious injury or product failure.

DO NOT modify the electrical wiring of this appliance. If the control power wiring is damaged or deteriorated then it **MUST** be replaced by an authorised person. Failure to do so may result in electric shock, fire, serious injury or product failure.

DO NOT install the air conditioner on an unstable or non level surface or where there may be a danger of it falling. It may result in death, serious injury, or product failure.

DO NOT install the outdoor unit where noise may cause nuisance.

DO NOT install the outdoor unit where it will be exposed to sea wind (salt spray) as this will reduce durability.

This appliance can be used by children aged from 8 years and above and persons with reduced physical, sensory or mental capabilities or lack of experience and knowledge if they have been given supervision or instruction concerning use of the appliance in a safe way and understand the hazards involved. Children shall not play with the appliance. Cleaning and user maintenance shall not be made by children without supervision. Refer to AS/NZS Standards and regulations.

This appliance is not intended for use by persons (including children) with reduced physical, sensory or mental capabilities, or lack of experience and knowledge, unless they have been given supervision or instruction concerning use of the appliance by a person responsible for their safety. Children should be supervised to ensure that they **DO NOT** play with the appliance.



MANDATORY INSPECTION PRIOR TO INSTALLATION

Immediately report any damage or discrepancies to the Supplier of the appliance. This appliance was inspected and tested at the time of manufacture and packaging, and released for transportation without known damage. Upon receipt, inspect the exterior for evidence of rough handling in shipment. Ensure that the appliance is labelled correctly for the gas and electrical supply, and/or other services it is intended to be connected to.

For safety and warranty purposes, appliances that may be damaged or incorrect **MUST NOT** be installed or operated under any circumstances. Installation of damaged or incorrect appliances may contravene local government regulations. Rinnai disclaims any liability or responsibility whatsoever in relation to the installation or operation of damaged or incorrect appliances.



ACHIEVING OPTIMAL PERFORMANCE

For optimal performance ensure to use the air conditioner within the following temperature ranges. Using the air conditioner outside of these ranges, will activate certain safety protection features, that will effect the appliances performance.

MODE	Cool Mode	Heat mode
Room Temperature	17°C ~ 32°C	0°C ~ 30°C
Outdoor Temperature	-15°C ~ 50°C	-25°C ~ 30°C

WARRANTY EXCLUSIONS

Rinnai product warranty excludes faults and failures caused by improper use and abuse; fair wear and tear; or failure to follow instructions regarding service and maintenance. It is very important that you maintain your appliance and have it serviced regularly. It is a condition of warranty that you adhere to the maintenance and service requirements as set out in this manual. Compliance with these requirements will prolong the useful life of your appliance and help ensure it operates efficiently. The “Service Maintenance Schedule” on page 17 and page 18 specifies specific items to be performed at prescribed intervals by qualified licensed technicians. The schedule should also be fully completed and retained as a record of who carried out the service, the date and actions taken.

IMPORTANT: Failure to carry out the requisite maintenance, servicing and recording requirements may void your product warranty. Please refer to “Warranty” on page 22 for full details.



CLEANING AND MAINTENANCE WARNINGS

- Turn off the device and switch the mains power off before cleaning. Failure to do so can cause electric shock
- **DO NOT** clean the air conditioner with excessive amounts of water.
- **DO NOT** clean the air conditioner with combustible cleaning agents. Combustible cleaning agents can cause fire or deformation



WARNINGS FOR PRODUCT USE

- If an abnormal situation arises (like a burning smell), immediately turn off the unit and disconnect the power. Call your dealer for instructions to avoid electric shock, fire or injury.
- **DO NOT** insert fingers, rods or other objects into the air inlet or outlet. This may cause injury, since the fan may be rotating at high speeds.
- **DO NOT** use flammable sprays such as hair spray, lacquer or paint near the unit. This may cause fire or combustion.
- **DO NOT** operate the air conditioner in places near or around combustible gases. Emitted gas may collect around the unit and cause explosion.
- **DO NOT** operate your air conditioner in a wet room such as a bathroom or laundry room. Too much exposure to water can cause electrical components to short circuit.
- **DO NOT** expose your body directly to cool air for a prolonged period of time.
- **DO NOT** allow children to play with the air conditioner. Children **MUST** be supervised around the unit at all times.
- If the air conditioner is used together with burners or other heating devices, thoroughly ventilate the room to avoid oxygen deficiency.
- In certain functional environments, such as kitchens, server rooms, etc., the use of specially designed air-conditioning units is highly recommended.



ELECTRICAL WARNINGS

- If any electrical cables are damaged, they **MUST** be replaced by a suitably qualified and trained service person in order to avoid any potential hazards.
- The product **MUST** be properly earthed at the time of installation, or electrical shock may occur.
- For all electrical work, follow all local and national wiring standards, regulations, and the Installation Manual. Connect cables tightly, and clamp them securely to prevent external forces from damaging the terminal. Improper electrical connections can overheat and cause fire, and may also cause shock. All electrical connections **MUST** be made according to the Electrical Connection Diagram located on the panels of the indoor and outdoor units.
- Appropriately specified and sized cables **MUST** be used, ensure all connections are tight. Clamp all cables sufficiently so that they cannot be pulled loose or disconnected.
- All wiring **MUST** be properly arranged to ensure that the control board cover can close properly. If the control board cover is not closed properly, it can lead to corrosion and cause the connection points on the terminal to heat up, catch fire, or cause electrical shock.
- A correctly specified and sized circuit breaker **MUST** be installed in accordance with all local and national wiring standards. A dedicated, independent electrical circuit is required for the system.
- **DO NOT** share the electrical outlet with other appliances. Improper or insufficient power supply can cause fire or electrical shock.
- If connecting power to fixed wiring, an all-pole disconnection device which has at least 3mm clearances in all poles, and have a leakage current that may exceed 10mA, the residual current device (RCD) having a rated residual operating current not exceeding 30mA, and disconnection **MUST** be incorporated in the fixed wiring in accordance with wiring rules.



Turn off the air conditioner and switch mains power off if you are not going to use it for a long time.

- Turn off and unplug the unit during storms.
- Make sure that water condensation can drain unhindered from the unit.
- **DO NOT** operate the air conditioner with wet hands. This may cause electric shock.
- **DO NOT** use device for any other purpose than its intended use.
- **DO NOT** climb onto or place objects on top of the outdoor unit.
- **DO NOT** allow the air conditioner to operate for long periods of time with doors or windows open, or if the humidity is very high.

SAFETY PRECAUTIONS



PRODUCT INSTALLATION WARNINGS

- Installation **MUST** be performed by an authorised dealer or specialist. Defective installation can cause water leakage, electrical shock, or fire.
- Installation **MUST** be performed according to the installation instructions and installed by an Authorised Person only. Improper installation can cause water leakage, electrical shock, or fire.
- Contact an authorised service technician for repair or maintenance of this unit. This appliance shall be installed in accordance with current wiring regulations.
- Only use the included accessories, parts, and specified parts for installation. Using non-standard parts can cause water leakage, electrical shock, fire, and can cause the unit to fail.
- Install the unit in a firm location that can support the unit's weight. If the chosen location cannot support the unit's weight, or the installation is not done properly, the unit may drop and cause serious injury and damage.
- Install drainage piping according to the instructions in this manual. Improper drainage may cause water damage to your home and property.
- For units that have an auxiliary electric heater, **DO NOT** install the unit within 1 metre of any combustible materials.
- **DO NOT** install the unit in a location that may be exposed to combustible gas leaks. If combustible gas accumulates around the unit, it may cause fire.
- **DO NOT** install the indoor unit under a floor or beneath a deck, to be installed in a roof space only.
- **DO NOT** turn on the power until all work has been completed.
- When moving or relocating the air conditioner, consult experienced service technicians for disconnection and reinstallation of the unit.
- How to install the appliance to its support, please read the information for details in "indoor unit installation" and "outdoor unit installation" sections.



FLUORINATED GASES

- This air-conditioning unit contains fluorinated greenhouse gases. For specific information on the type of gas and the amount, please refer to the relevant label on the unit itself or the "Owner's Manual" in the packaging of the outdoor unit.
- Installation, service, maintenance and repair of this unit must be performed by a certified technician.
- Product uninstallation and recycling **MUST** be performed by a certified technician.
- For equipment that contains fluorinated greenhouse gases in quantities of 5 tonnes of CO₂ equivalent or more, but less than 50 tonnes of CO₂ equivalent, if the system has a leak-detection system installed, it **MUST** be checked for leaks at least every 24 months.
- When the unit is checked for leaks, proper record-keeping of all checks is strongly recommended



FUSE SPECIFICATIONS

The air conditioner's circuit board (PCB) is designed with a fuse to provide overcurrent protection. The specifications of the fuse are printed on the circuit board, such as:

- T5A/250VAC, T10A/250VAC, etc.
- T20A/250VAC(<=7kW units), T30A/250VAC(>7kW units)

NOTE: For the units with R32, only the blast-proof ceramic fuse can be used.



A NOTE ON ILLUSTRATIONS

The illustrations used in this manual are for explanatory purposes only and the shape of your indoor unit may vary slightly from that which is shown in this manual.

Minimum Room Size

Amount of refrigerant to be charged (kg)	Installation height (m)	Minimum room area (m ²)	Amount of refrigerant to be charged (kg)	Installation height (m)	Minimum room area (m ²)
1.0	0.6 /1.8 /2.2	9 /1 /1	1.95	0.6 /1.8 /2.2	33 /4 /2.5
1.05	0.6 /1.8 /2.2	9.5 /1.5 /1	2.0	0.6 /1.8 /2.2	34.5 /4 /3
1.1	0.6 /1.8 /2.2	10.5 /1.5 /1	2.05	0.6 /1.8 /2.2	36 /4 /3
1.15	0.6 /1.8 /2.2	11.5 /1.5 /1	2.1	0.6 /1.8 /2.2	38 /4.5 /3
1.2	0.6 /1.8 /2.2	12.5 /1.5 /1	2.15	0.6 /1.8 /2.2	40 /4.5 /3
1.25	0.6 /1.8 /2.2	13.5 /1.5 /1	2.2	0.6 /1.8 /2.2	41.5 /5 /3.5
1.3	0.6 /1.8 /2.2	14.5 /2 /1.5	2.25	0.6 /1.8 /2.2	43.5 /5 /3.5
1.35	0.6 /1.8 /2.2	16 /2 /1.5	2.3	0.6 /1.8 /2.2	45.5 /5 /3.5
1.4	0.6 /1.8 /2.2	17 /2 /1.5	2.35	0.6 /1.8 /2.2	47.5 /5.5 /4
1.45	0.6 /1.8 /2.2	18 /2 /1.5	2.4	0.6 /1.8 /2.2	49.5 /5.5 /4
1.5	0.6 /1.8 /2.2	19.5 /2.5 /1.5	2.45	0.6 /1.8 /2.2	51.5 /6 /4
1.55	0.6 /1.8 /2.2	21 /2.5 /2	2.5	0.6 /1.8 /2.2	54 /6 /4
1.6	0.6 /1.8 /2.2	22 /2.5 /2	2.55	0.6 /1.8 /2.2	56 /6.5 /4.5
1.65	0.6 /1.8 /2.2	23.5 /3 /2	2.6	0.6 /1.8 /2.2	58 /6.5 /4.5
1.7	0.6 /1.8 /2.2	25 /3 /2	2.65	0.6 /1.8 /2.2	60.5 /7 /4.5
1.75	0.6 /1.8 /2.2	26.5 /3 /2	2.7	0.6 /1.8 /2.2	63 /7 /5
1.8	0.6 /1.8 /2.2	28 /3.5 /2.5	2.75	0.6 /1.8 /2.2	65 /7.5 /5
1.85	0.6 /1.8 /2.2	29.5 /3.5 /2.5	2.8	0.6 /1.8 /2.2	67.5 /7.5 /5
1.9	0.6 /1.8 /2.2	31 /3.5 /2.5	2.85	0.6 /1.8 /2.2	70 /8 /5.5

- All minimum room sizes in the above table are calculated on the base charge provided with the outdoor unit.
- Mechanical connectors used indoors shall comply with ISO 14903.
- This appliance shall be installed in accordance with AS/NZS 5149.
- When mechanical connectors are reused, sealing parts shall be renewed.
- When flared joints are reused, the flare part shall be re-fabricated.



Certain types of refrigerant (Including R32) require minimum room sizes. Please ensure that these minimum room sizes are adhered to for standard installations (up to pre-charged pipe lengths). If larger refrigerant charges than standard are used, then consult AS/NZS 60335.2.40 to determine the safe minimum floor area for the installation.

UNIT PARTS AND MAJOR FUNCTIONS

Use a soft dry cloth to wipe the indoor unit clean, if especially dirty, you may use a warm damp cloth.

(A) Wall-mounted type

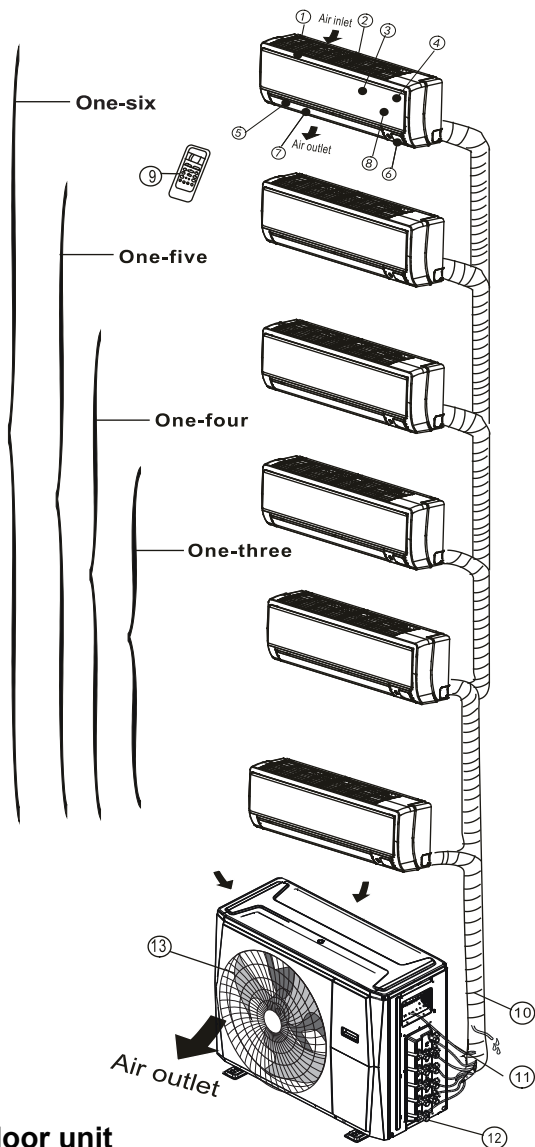

Indoor unit

1. Panel frame
2. Rear air intake grille
3. Front panel
4. Air purifying filter & Air filter (back)
5. Horizontal louver
6. LCD display window
7. Vertical louver
8. Manual control button (back)
9. Remote controller holder

Outdoor unit

10. Drain hose, refrigerant connecting pipe
11. Connective cable
12. Stop valve
13. Fan hood

(B) Duct / Ceiling type

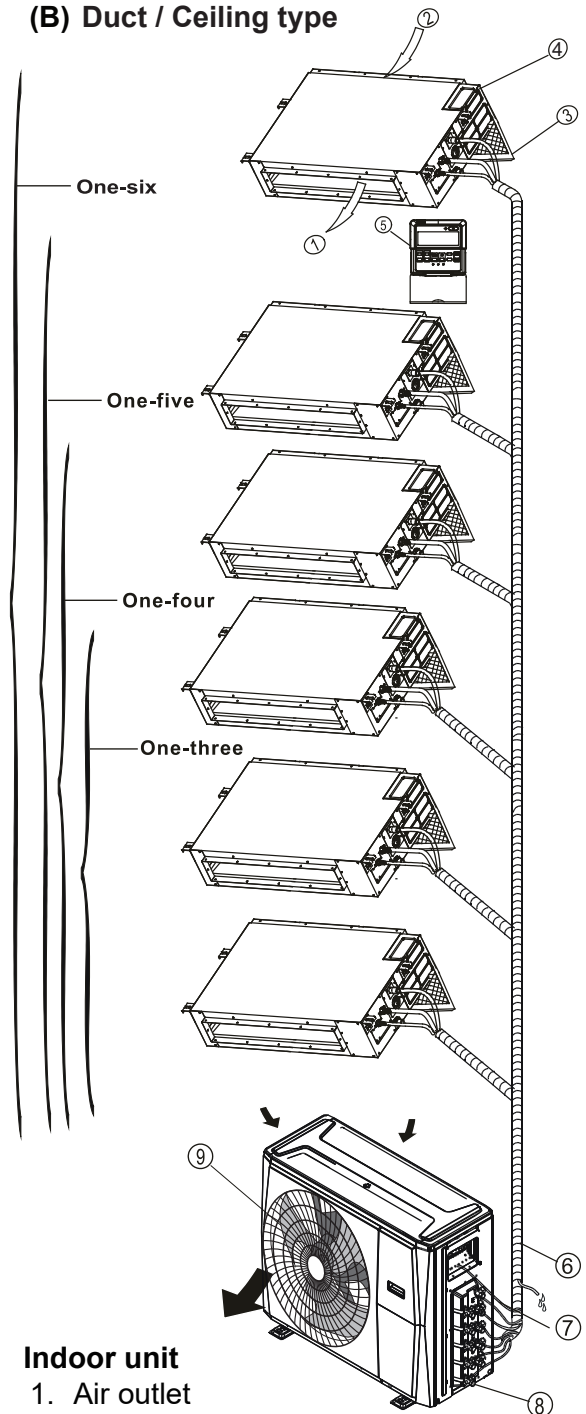

Indoor unit

1. Air outlet
2. Air inlet
3. Air filter
4. Electric control cabinet
5. Wire controller

Outdoor unit

6. Drain hose, refrigerant connecting pipe
7. Connective cable
8. Stop valve
9. Fan hood

(C) Floor and standing type (Console)

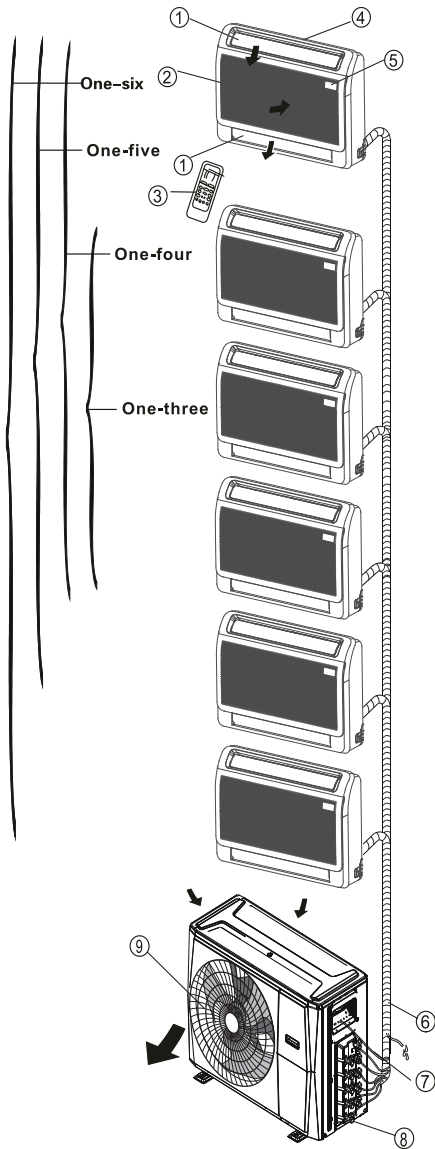

Indoor unit

- 1. Air flow louver (at air outlet)
- 2. Air inlet
- 3. Remote controller
- 4. Installation part
- 5. Display panel

Outdoor unit

- 6. Drain hose, refrigerant connecting pipe
- 7. Connective cable
- 8. Stop valve
- 9. Fan hood

(D) Compact four-way cassette type

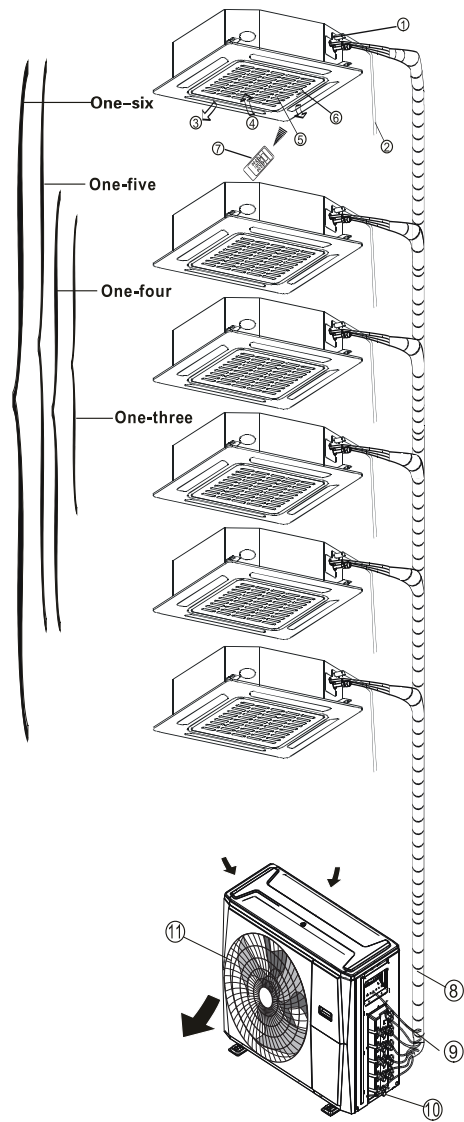

Indoor unit

- 1. Drain pump (drain water from indoor unit)
- 2. Drain hose
- 3. Air outlet
- 4. Air inlet
- 5. Air-in grill
- 6. Display panel
- 7. Remote controller

Outdoor unit

- 8. Refrigerant connecting piping
- 9. Connecting cable
- 10. Stop valve
- 11. Fan hood



For multi-split type air conditioners, one outdoor unit can be matched to different types of indoor units. All of the pictures in this manual are for demonstration purposes only. Your air conditioner may be slightly different, if similar in shape. The following pages introduce several kinds of indoor units that can be matched with the outdoor units.

OPERATING TEMPERATURE

When your air conditioner is used outside of the following temperature ranges, certain safety protection features may activate and cause the unit to disable.

Modes	COOL	HEAT	DRY
Room Temperature	17°C – 32°C	0°C – 30°C	10°C – 32°C
Outdoor Temperature	0°C – 50°C	-15°C – 24°C	0°C – 50°C
	-15°C – 50°C (For models with low temperature cooling systems.)		
	0°C – 52°C (For special tropical models)		0°C – 52°C (For special tropical models)

FOR OUTDOOR UNITS WITH AUXILIARY ELECTRIC HEATER

When outside temperature is below 0°C, we strongly recommend keeping the unit plugged in at all times to ensure smooth ongoing performance.



Room relative humidity less than 80%. If the air conditioner operates in excess of this figure, the surface of the air conditioner may attract condensation. Please set the vertical air flow louver to its maximum angle (vertically to the floor), and set on HIGH fan mode.

To further optimise the performance of your unit, do the following:

Keep doors and windows closed.

- Limit energy usage by using TIMER ON and TIMER OFF functions.
- **DO NOT** block air inlets or outlets.
- Regularly inspect and clean air filters.

FEATURES**Protection of the air conditioner Compressor protection**

- The compressor cannot restart for 3 minutes after it stops.

Anti-cold air (Cooling and heating models only)

- The unit is designed not to blow cold air on HEAT mode, when the indoor heat exchanger is in one of the following three situations and the set temperature has not been reached.
 - When heating has just started.
 - During defrosting.
 - Low temperature heating.
- The indoor or outdoor fan stop running when defrosting (Cooling and heating models only).

Defrosting (Cooling and heating models only)

- Frost may be generated on the outdoor unit during a heat cycle when outdoor temperature is low and humidity is high resulting in lower heating efficiency in the air conditioner.
- Under these conditions, the air conditioner will stop heating operation and start defrosting automatically.
- The time to defrost may vary from 4 to 10 minutes, depending on the outdoor temperature and the amount of frost build-up on the outdoor unit.

Auto-Restart (some models)

In case of power failure, the system will immediately stop. When power returns, the Operation light on the indoor unit will flash. To restart the unit, press the **ON/OFF** button on the remote control. If the system has an auto restart function, the unit will restart using the same settings.

White mist emerging from the indoor unit

- A white mist may be generated due to a large temperature difference between air inlet and air outlet on COOL mode in places with high relative humidity.
- A white mist may be generated due to moisture created in the defrosting process when the air conditioner restarts in HEAT mode operation after defrosting.

Noise coming from the air conditioner

- You may hear a low hissing sound when the compressor is running or has just stopped running. This sound is the sound of the refrigerant flowing or coming to a stop.
- You may also hear a low "squeaking" sound when the compressor is running or has just stopped running. This is caused by temperature heat expansion and cold contraction of the plastic parts in the unit when the temperature is changing.
- A noise may be heard due to the louver restoring itself to its original position when power is first turned on.

Dust blowing out from the indoor unit.

- This happens when the air conditioner has not been used for a long time or during its first use.

Smell emitting from the indoor unit.

- This is caused by the indoor unit giving off smells permeated from building materials, furniture, or smoke.

The air conditioner turns to **FAN ONLY** mode from **COOL** or **HEAT** (for cooling and heating models only) mode.

When the indoor temperature reaches the set temperature setting, the compressor will stop automatically, and the air conditioner turns to FAN only mode. The compressor will start again when the indoor temperature rises on COOL mode or falls on HEAT mode to the set point.

Droplets of water may form on the surface of the indoor unit when cooling occurs in relatively high humidity (defined as higher than 80%). Adjust the horizontal louver to the maximum air outlet position and select HIGH fan speed.

Heating mode (For cooling and heating models only)

The air conditioner draws in heat from the outdoor unit and releases it via the indoor unit during heating. When the outdoor temperature falls, heat drawn in by the air conditioner decreases accordingly. At the same time, heat loading of the air conditioner increases due to larger difference between indoor and outdoor temperature. If a comfortable temperature cannot be achieved with the air conditioner alone, it is recommended that you use a supplementary heating device.

Lightning or a car wireless telephone operating nearby may cause the unit to malfunction. Disconnect the unit from its power source and then re-connect the unit with the power source again. Push the ON/OFF button on the remote controller to restart operations.

ENERGY SAVING TIPS

- **DO NOT** set the unit to excessive temperature levels.
- While cooling, close the curtains to avoid direct sunlight.
- Doors and windows should be kept closed to keep cool or warm air in the room.
- **DO NOT** place objects near the air inlet and outlet of the unit. This will reduce the efficiency of the unit.
- Set a timer and use the built-in SLEEP/ECONOMY mode if applicable.
- If you don't plan to use the unit for a long time, remove the batteries from the remote controller.
- Clean the air filter every two weeks. A dirty filter can reduce cooling or heating efficiency.
- Adjust louvers properly and avoid direct airflow.

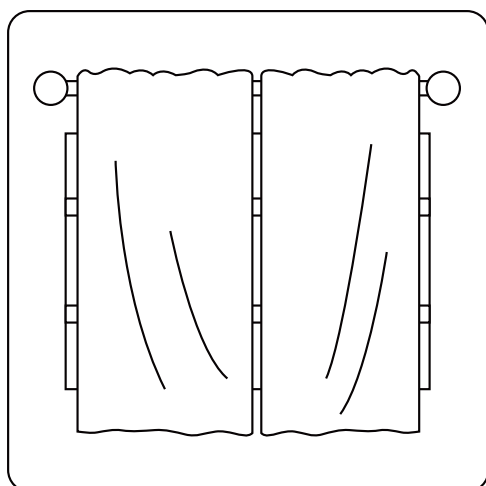

Closing curtains during heating also helps keep the heat in

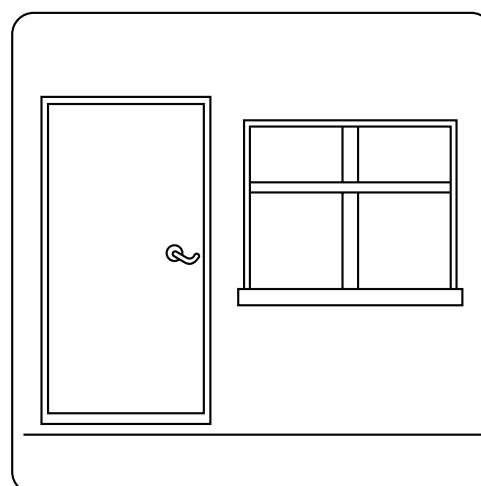

Doors and windows should be kept closed

MANUAL OPERATION – MODE SELECTION

While two or more indoor units are simultaneously operating, make sure the modes do not conflict with each other. The heat mode claims precedence over all other modes. If the unit initially started to operate in HEAT mode, the other units can operate in HEAT mode only. For example: If the unit initially started operates under COOL (or FAN) mode, the other units can operate under any mode except HEAT.

If one of the units selects HEAT mode, the other operating units will stop operation and display "--" (for units with display window only) or the auto and operation indication light will flash rapidly, the defrost indication light will turn off, and the timer indication light will remain on (for units without a display window).

Alternatively, the defrost and alarm indication light (if applicable) will light up, or the operation indication light will flash rapidly, and the timer indication light will turn off (for the floor and standing type).

OPTIMAL OPERATION

To achieve optimal performance, please note the following:

- Adjust the direction of the air flow so that it is not blowing directly on people.
- Adjust the temperature to achieve the highest possible level of comfort. **DO NOT** adjust the unit to excessive temperature levels.
- Close doors and windows in COOL mode or HEAT mode.
- Use the TIMER ON button on the remote controller to select a time you want to start your air conditioner.
- **DO NOT** place any object near the air inlet or air outlet, as the efficiency of the air conditioner may be reduced and the air conditioner may stop running.
- Clean the air filter periodically, otherwise cooling or heating performance may be reduced.
- **DO NOT** operate unit with horizontal louvre in closed position.

RECOMMENDED

For units that feature an electric heater, when the outside ambient temperature is below 0°C, it is strongly recommended that you to keep the machine plugged in so as to guarantee smooth operation.

CARE & MAINTENANCE

CLEANING THE INDOOR UNIT

Use a soft dry cloth to wipe the indoor unit clean, if especially dirty, you may use a warm damp cloth.



Turn off the power before you perform any maintenance; otherwise it may cause electric shock.

DO NOT use water to clean the inside of the indoor unit. This can destroy insulation and cause electrical shock.

DO NOT use chemicals or chemically treated cloths to clean the unit.

DO NOT use benzene, paint thinners, polishing powder or other solvents to clean the unit. They can cause the plastic surface to crack or deform.

NEVER use water that is hotter than 40°C when you clean the front panel. It may cause deformation or discolouration.

CLEANING THE AIR FILTER (WALL MOUNTED UNITS)

The air filters require inspection and cleaning at least every two weeks. Consult your installer for location of filters on ducted systems.



A dirty air filter will reduce the efficiency, effectiveness and air quality of your system. Failure to clean the filters regularly can also cause condensation to form and drip from the indoor unit when operated in cooling mode during humid conditions.

For replacement filters, please contact Rinnai.



Turn off the power before you perform any maintenance; otherwise it may cause electric shock.

When removing filter, **DO NOT** touch metal parts in the unit. The sharp metal edges can cut you.

DO NOT use chemicals or chemically treated cloths to clean the filters.

DO NOT use benzene, paint thinners, polishing powder or other solvents. They can cause the plastic surface to crack or deform.

NEVER use water that is hotter than 40°C when you clean the filters. It may cause deformation or discolouration.

NEVER use volatile substances when you clean the filters. They may damage the surface of the product.

DO NOT expose filter to direct sunlight when drying as this can shrink the filter.

Ensure filters completely dry before re-inserting.

NEVER operate the system without the filter in place.

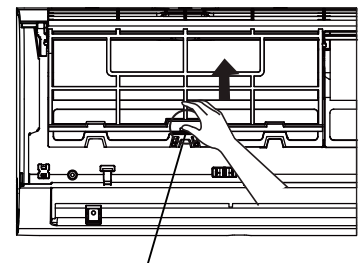

Filter Tab

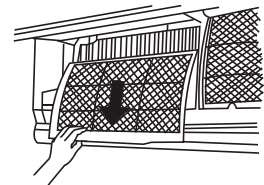

Remove air freshening filter from back of larger filter (some units)

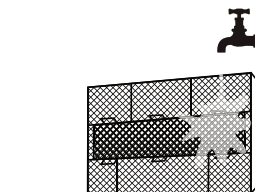

The air filter is located under the top air inlet grill.

1. Grip the tab on the end of the filter, lift it up, then pull it towards yourself.
2. If your filter has a small air freshening filter, lift the front panel of the indoor unit, unclip it from the filter holder and clean filter with a hand-held vacuum cleaner.
3. Clean the filter with a vacuum cleaner or with warm water. If dirt is difficult to remove, wash the filter in lukewarm water with mild detergent.
4. Rinse the filter with fresh water, then shake off excess water.
5. Dry it in a cool, dry place, and refrain from exposing it to direct sunlight.
6. Ensure to re-insert the filter securely after cleaning, observing the same orientation as when removed.
7. Close the front panel of the indoor unit.

CLEANING THE OUTDOOR UNIT

The outdoor (condensing) unit draws air into the unit and dissipates it away from the appliance. Periodic inspection is required to ensure vegetation has not grown around the unit (plants, weeds etc.).

The cabinet should be kept clean and have the recommended clearances maintained. Ensure the discharge air is free to dissipate and under no circumstances recirculates back into the unit.

Ensure there is no water build up (including from condensate drain) on or around the unit.



Any maintenance and cleaning of the outdoor unit should be performed by an authorised dealer or licensed service provider.

Any unit repairs **MUST be performed by an authorised dealer or licensed service provider.**

GENERAL MAINTENANCE

Maintenance - For Prolonged Periods of Non Use

If you plan not to use your air conditioner for an extended period of time, do the following.

- Clean the indoor unit and air filters.
- Select FAN ONLY mode and let the indoor fan run for a time to dry the inside of the unit.
- Disconnect the power supply and remove the battery from the remote control.
- Check components of the outdoor unit periodically. Contact a local dealer or a customer service centre if the unit requires servicing.



Before you clean the air conditioner, be sure to switch off the unit and disconnect the power supply plug.

When the air conditioner is to be used again

After long periods of non-use, or before periods of frequent use, do the following:

- Use a dry cloth to wipe off the dust accumulated on the rear air intake grille in order to avoid the dust being dispersed from the indoor unit.
- Check that the wiring is not broken off or disconnected.
- Check that the air filter is installed.
- Make sure nothing is blocking all air inlets and outlets of both the indoor or outdoor units

INSTALLATION RECORD - INSTALLER DETAILS

Company Name: _____

Company Address: _____

Telephone: _____

Mobile Phone: _____

Email: _____

Certificate of Compliance / Certification No. _____

Authorised Persons - Licence No. _____

Installers Name: _____

Installers Signature: _____

Installation Date: _____

INSTALLATION RECORD - SYSTEM DETAILS

Model Number : _____

Serial Number Indoor Unit: _____

Serial Number Outdoor Unit: _____

Installation Address: _____

CUSTOMER CARE PROGRAM

Please ensure you register your product warranty on line at rinnai.com.au.

The Rinnai Customer Care Program is designed to help you get the most out of your new system.

Service and maintenance in accordance with the Service Maintenance Schedules on page 18 and page 19 are essential in ensuring the prolonged useful life of your system, and help ensure it operates at optimum efficiency. We may contact you before each winter or summer season with preferential offers for preventative maintenance services which will keep your Rinnai system in great condition.



Service maintenance is not covered under warranty and is a chargeable service. All units **MUST have safe and reasonable access and be installed in compliance with the installation instructions supplied with the unit. Some installations may require two service personnel to attend, in accordance with Health and Safety requirements.**

Also note that all refrigerated air conditioning systems have air filters that require regular inspection and cleaning. Please refer to "Cleaning the Air Filter (Wall Mounted Units)" on page 15.

SERVICE MAINTENANCE SCHEDULE - NON DUCTED AIR CONDITIONING SYSTEMS

Your Rinnai Air Conditioning System should be maintained annually after the date of installation by a qualified licensed technician in accordance with the Schedule below. Failure to do so during the product warranty period may void your warranty. This periodic service and maintenance will prolong the useful life of the unit, and help keep it running safely and at optimum efficiency.

Date of Installation	/ /		Installed By:			
Service Year	1	2	3	4	5	6
Service Date	/ /	/ /	/ /	/ /	/ /	/ /
Service Company / Technician						
Ambient Temperature at CDU (°C)						
ELECTRICAL						
Wiring, Electrical connections						
Fan Motors						
Capacitors (if applic)						
Printed circuit boards						
MAJOR COMPONENTS						
Outdoor unit clearances						
Outdoor unit condensate tray						
Outdoor unit condensate drain						
Outdoor unit fixing						
Indoor unit condensate tray						
Indoor unit condensate drain / pump						
Refrigerant charge						
Refrigeration connections						
Fan assemblies						
Return Air grille & filters						
CONTROLS						
Louver operation						
Remote operation						
System Operation						
Sequence of operation						
Return Air Temp - Cooling/ Heating	°C	°C	°C	°C	°C	°C
Outlet Air Temp - Cooling / Heating	°C	°C	°C	°C	°C	°C
Outdoor unit - Liquid line pressure	kPa	kPa	kPa	kPa	kPa	kPa
Outdoor unit - Suction line pressure	kPa	kPa	kPa	kPa	kPa	kPa
GENERAL INSTALLATION-RELATED AND 3rd PARTY COMPONENTS (NOT RINNAI PRODUCTS) *						
Airflow through system						
Refrigerant pipework						
Safety tray						
Wall mounting						
CONSUMABLES **						
Capacitors						
Filters						
Batteries (If applic)						
* Installation and other field-supplied components are not covered by Rinnai Product Warranty. These include, but are not limited to, control wiring, refrigerant gas and electrical connections to the appliance. These should be inspected as they can affect the performance, reliability and safety of the system.						
** Units contain consumable items that may require periodic replacement and are not covered by Rinnai product warranty (e.g. filters, capacitors and batteries)						
ACTION CODES						
Inspected - Working Correctly - No Action Required	Adjusted Part	Cleaned Part	Replaced Part	Repaired Part	Referred to Installer	
✓	A	C	R	RP	RI	

SERVICE MAINTENANCE SCHEDULE - DUCTED AIR CONDITIONING SYSTEMS

Your Rinnai Ducted Air Conditioning System should be maintained annually after the date of installation by a qualified licensed technician in accordance with the Schedule below. Failure to do so during the product warranty period may void your warranty. This periodic service and maintenance will prolong the useful life of the unit, and help keep it running safely and at optimum efficiency.

Date of Installation	/ /		Installed By:			
YEAR OF SERVICE	1	2	3	4	5	6
Service Date	/ /	/ /	/ /	/ /	/ /	/ /
Service Company / Technician						
Ambient Temperature at CDU (°C)						
ELECTRICAL						
Wiring, Electrical connections						
Fan Motors						
Capacitors (if Applicable)						
Printed circuit boards						
MAJOR COMPONENTS						
Outdoor unit clearances						
Outdoor unit condensate tray						
Outdoor unit condensate drain						
Outdoor unit fixing						
Indoor unit clearances						
Indoor unit condensate tray						
Indoor unit condensate drain						
Refrigerant charge						
Refrigeration connections						
Fan assemblies						
CONTROLS						
Thermostat(s)						
Zone Controls (If Applicable)						
SYSTEM OPERATION						
Sequence of operation						
Return Air Temp - Cooling/ Heating	°C	°C	°C	°C	°C	°C
Outlet Air Temp - Cooling / Heating	°C	°C	°C	°C	°C	°C
Outdoor unit - Liquid line pressure	kPa	kPa	kPa	kPa	kPa	kPa
Outdoor unit - Suction line pressure	kPa	kPa	kPa	kPa	kPa	kPa
Zone Operation (If Applicable)						
GENERAL INSTALLATION-RELATED AND 3rd PARTY COMPONENTS (NOT RINNAI PRODUCTS) *						
Ductwork and fittings						
Return Air grille & filters						
Airflow through system						
Refrigerant pipework						
Safety tray						
Zone motors						
CONSUMABLES **						
Capacitors						
Filters						
Batteries (If applicable)						
* Installation and other field-supplied components are not covered by Rinnai Product Warranty. These include, but are not limited to, control wiring, ducting, return air filter(s) grille, register, diffuser, zone motors, controls/thermostats, pipework, fabricated or added components and refrigerant gas and electrical connections to the appliance. These should be inspected as they can affect the performance, reliability and safety of the system.						
** Units contain consumable items that may require periodic replacement and are not covered by Rinnai product warranty (e.g. filters, capacitors and batteries)						
ACTION CODES						
Inspected - Working Correctly - No Action Required	Adjusted Part	Cleaned Part	Replaced Part	Repaired Part	Referred to Installer	
✓	A	C	R	RP	RI	

SAVE A SERVICE CALL



The following issues are not a malfunction and in most situations will not require repairs.

If problems persist contact a local dealer or your nearest customer service centre.

Provide them with a detailed description of the unit malfunction as well as your model number.

SYMPTOM	CAUSE
Unit does not turn on when pressing ON/OFF button.	The unit has a 3 minute protection feature that prevents the unit from overloading. The unit cannot be restarted within three minutes of being turned off.
	Cooling and Heating Models: If the Operation light and PRE-DEF (Pre-heating/Defrost) indicators are lit up, the outdoor temperature is too cold and the unit's anti-cold wind is activated in order to defrost the unit.
	In Cooling-only Models: If the "Fan Only" indicator is lit up, the outdoor temperature is too cold and the unit's anti-freeze protection is activated in order to defrost the unit.
The unit changes from COOL mode to FAN mode.	The unit may change its setting to prevent frost from forming on the unit. Once the temperature increases, the unit will start operating in the previously selected mode again.
	The set temperature has been reached, at which point the unit turns off the compressor. The unit will resume operation when the temperature fluctuates again.
The indoor unit emits white mist	Condensation effect that can occur during cooling operations and is normal. In humid regions, a large temperature difference between the room air and the conditioned air can cause white mist.
Both the indoor and outdoor units emit white mist.	When the unit restarts in HEAT mode after defrosting, white mist may be emitted due to moisture generated from the defrosting process.
The indoor unit makes noises.	A squeaking sound is heard when the system is OFF or in COOL mode. The noise is also heard when the drain pump (optional) is in operation.
	A squeaking sound may occur after running the unit in HEAT mode due to expansion and contraction of the unit's plastic parts.
Both the indoor unit and outdoor unit make noises.	Low hissing sound during operation: This is normal and is caused by refrigerant gas flowing through both indoor and outdoor units.
	Low hissing sound when the system starts, has just stopped running, or is defrosting: This noise is normal and is caused by the refrigerant gas stopping or changing direction.
	Squeaking sound: Normal expansion and contraction of plastic and metal parts caused by temperature changes during operation can cause squeaking noises.
The outdoor unit makes noises.	The unit will make different sounds based on its current operating mode.
Dust is emitted from either the indoor or outdoor unit.	The unit may accumulate dust during extended periods of non-use, which will be emitted when the unit is turned on. This can be mitigated by covering the unit during long periods of inactivity.
The unit emits a bad odour	The unit may absorb odours from the environment (such as furniture, cooking, cigarettes, etc.), which may be emitted during operation.
	The unit's filters have become mouldy and should be cleaned.
The fan of the outdoor unit does not operate.	During operation, the fan speed is controlled to optimise performance.

TROUBLESHOOTING TIPS

When problems occur, please check the following possible causes before contacting a repair company.

PROBLEM	POSSIBLE CAUSES	SOLUTION
The air conditioner stops running	Power failure	Wait for the power to be restored
	The power switch is off	Turn on the power
	The fuse is burned out	Replace the fuse
	Remote control batteries are dead	Replace the remote control batteries
	The unit's 3-minute protection has been activated	Wait three minutes after restarting the unit
Poor heating performance	Temperature setting may be higher than the ambient room temperature	Lower the temperature setting
	The heat exchanger on the indoor or outdoor unit is dirty	Clean the affected heat exchanger
	The air filter is dirty	Remove the filter and clean it according to instructions
	The air inlet or outlet of either unit is blocked	Turn the unit off, remove the obstruction and turn it back on
	Doors and windows are open	Make sure that all doors and windows are closed while operating the unit
	Excessive heat is generated by sunlight	Close windows and curtains during periods of high heat or bright sunshine
	Low refrigerant due to leak or long-term use	Check for leaks, re-seal if necessary and top off refrigerant
The unit starts and stops frequently	There's too much or too little refrigerant in the system	Check for leaks and recharge the system with refrigerant
	There is air, incompressible gas or foreign material in the refrigeration system.	Evacuate and recharge the system with refrigerant
	System circuit is blocked	Determine which circuit is blocked and replace the malfunctioning piece of equipment
	The compressor is broken	Replace the compressor
	The voltage is too high or too low	Install a manostat to regulate the voltage
Poor heating performance	The outdoor temperature is lower than 7°C (44.5°F)	Check for leaks and recharge the system with refrigerant
	Cold air is entering through doors and windows	Make sure that all doors and windows are closed during use
	Low refrigerant due to leak or long-term use	Check for leaks, re-seal if necessary and top off refrigerant

WHEN TO CALL FOR SERVICE



If ANY of the following conditions occurs, turn off your unit immediately!

- The power cord is damaged or abnormally warm
- There is a burning smell coming from the unit
- The unit emits loud or abnormal sounds
- When operated if a circuit breaker (safety, ground) is thrown or a fuse is blown
- Water leaks from the indoor unit even when the humidity level is low
- Parts are ejected out of the unit
- Water or foreign objects fall into the unit
- If the unit has been exposed to flooding

DO NOT ATTEMPT TO FIX THESE YOURSELF!

TURN OFF THE AIR CONDITIONER, AND CONTACT RINNAI OR AN AUTHORISED SERVICE PROVIDER IMMEDIATELY.

DISPOSAL GUIDELINES

This appliance contains refrigerant and other potentially hazardous materials. When disposing of this appliance, the law requires special collection and treatment. **DO NOT** dispose of this product as household waste or unsorted municipal waste.

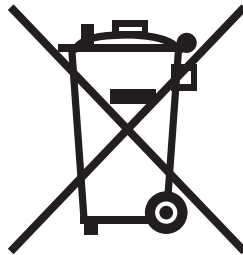

Special notice – Disposing of this appliance in the forest or other natural surroundings endangers your health and is bad for the environment. Hazardous substances may leak into the ground water and enter the food chain.

TERMS OF WARRANTY – AUSTRALIA

Rinnai Australia Pty. Ltd. ABN 74 005 138 769, 100 Atlantic Drive, Keysborough VIC 3173.

1 DEFINITIONS

The terms listed below shall have the following meanings:

- 1 **“Authorised Service Representative”** means an independent service contractor authorised by Rinnai or Rinnai service personnel.
- 2 **“Rinnai”** means Rinnai Australia Pty Ltd (ABN 74 005 138 769) and any related company.
- 3 **“Certificate(s) of Compliance”** means certificate(s) issued by licensed personnel (including plumbers, refrigeration mechanics, electricians or other relevant tradespeople) to certify that any prescribed works comply with applicable regulatory requirements.
- 4 **“Certificate(s) of Occupancy”** means certificate(s) issued by the local government authority (or similar organisation) which certifies that a home can be occupied.
- 5 **“Installation Site”** means the site at which the Product is originally installed.
- 6 **“Normal Business Hours”** means 8:30am to 5:00pm Monday to Friday, excluding public holidays.
- 7 **“Operating/Installation Instructions”** means the user manual or other documentation which provides detailed instructions on the proper operation and maintenance of the Product.
- 8 **“Other Applications”** means any Product used for purposes other than Residential & Light Commercial Applications. Other Applications may include but are not limited to factory, IT/Server room, telephone exchange, processing area (e.g. bakery, kitchen, warehouse, swimming pool, agricultural facilities such as a nursery). Any Product which has been installed, for whatever purpose, as a retrofit component to an existing system, will also be classed as being part of an “Other Application” regardless of the purpose of use of the existing system into which such product has been installed.
- 9 **“Purchaser”** means the end user of the Product, the person named as owner in the Warranty certificate, the holder of the Proof of Purchase or the holder of a property transfer document where the Product is included as part of the chattels.
- 10 **“Product”** means the equipment purchased by the Purchaser and described in Section 2 of this document.
- 11 **“Proof of Purchase”** means a Tax Invoice or Receipt in respect of the Product. In the case of new constructions, a Certificate of Occupancy or a Certificate of Compliance that details the date of installation or commissioning will suffice.
- 12 **“Qualified Installer”** means the qualified installation contractor who is responsible for performing the installation work in the manner prescribed by local and statutory regulations, including compliance with any relevant and to Rinnai specifications, including Australian Standards.
- 13 **“Residential & Light Commercial Applications”** means any Product for use in residential or light commercial applications where
 - a) the Product is solely used for the purpose of human comfort; and
 - b) the ambient temperature of the space the Product is intended to heat or cool is influenced solely or primarily by natural exterior weather conditions rather than by man-made or mechanical heat sources.

Examples of Residential & Light Commercial Applications include, homes, offices, hotels, apartments, nursing homes, hospitals, health care premises, shopping centres, and retail stores.

2 TERMS OF WARRANTY

2.1 Subject to the Terms of Warranty set out in this document, effective from the date of purchase by the Purchaser, the Product is warranted to be free from defects in materials & factory workmanship for the period set out in table below:

	PRODUCT GROUPS	PARTS	LABOUR
Residential and Light Commercial	Evaporative Coolers & Ducted Gas Heaters (excluding Compact Classic Series)	5 Years *Extended 4 Years Option	5 Years *Extended 4 Years Option
	Ducted Gas Heaters - Compact Classic Series	3 Years	3 Years
	Refrigerated Air conditioning Products	5 Years	5 Years
	Ducted Gas Heaters - Heat Exchangers and Burners Evaporative Coolers - Structural components only	10 Years	N/A
	Portable Air conditioning / Dehumidifier / Air Purifier	2 Years	N/A
	Electric Panel Heaters ⁽¹⁾	7 Years	N/A
	Electric Fire Heater	5 Years	5 Years
	Wi-Fi Devices	1 Year	1 Year
Other Applications	All Product Groups	2 Years	1 Year
After Market	Spare Parts	1 Year	N/A
*Extended Warranty Option	Up to 4 year extended warranty (in addition to the standard warranty period listed above) applies on selected products when you opt in to the Rinnai Service Advantage program. This program has terms and conditions, including the requirement for scheduled servicing of the product by Rinnai. To participate in the program you must register your product online at: www.rinnai.com.au/support-resources/warranty-registration/ within the first 12 months of the product being installed.		

⁽¹⁾ To make a claim under this warranty, please contact your place of purchase within the warranty period.

- 2.2 Rinnai will determine in its sole discretion, which classification the Product fits into and the corresponding Warranty that shall apply.
- 2.3 An Authorised Service Representative will repair or replace, at its option, the Product or any part of the Product that its examination shows to be defective. The repair or replacement shall be performed during Normal Business Hours by an Authorised Service Representative. Repair by persons other than an Authorised Service Representatives may void the Warranty.
- 2.4 Alternatively to clause 2.3 above, Rinnai can at its discretion elect to pay you an amount equivalent to the cost of repairing or replacing the Product.
- 2.5 If Rinnai provides you with either the replacement costs or replacement product, ownership of the original Product shall immediately transfer to Rinnai.
- 2.6 Rinnai is responsible for reasonable costs associated with legitimate warranty claims, including call-out of an Authorised Service Representative to inspect the Product. Rinnai is not responsible for:
 - a) costs for tradespeople engaged by you that are not Rinnai Authorised Service Representatives.
 - b) any costs, including call out costs for a Rinnai Authorised Service Representatives, associated with a Product which is determined upon inspection not to be covered by this warranty.
- 2.7 Rinnai will reimburse any reasonable costs associated with making a legitimate warranty claim against Rinnai which are not otherwise specified above.
- 2.8 The Warranty of the Product requires that, in addition to all other conditions, the Purchaser conducts regular and/or preventative maintenance as may be specified by the Operating/Installation Instructions or otherwise directed by Rinnai and required by the level of usage and the usage environment, including the use of correct and uncontaminated refrigerants and lubricants. Refrigeration, plumbing and electrical works must be undertaken by licensed personnel.
- 2.9 Where a Product or failed component is replaced under warranty, the time remaining on the original Product warranty period will continue to apply and the replacement product or part will be subject to the original warranty period only.

3 CONDITIONS OF WARRANTY

- 3.1 The Purchaser may only obtain the benefit of the Warranty if the Purchaser:
- maintains and has the Product serviced in accordance with the instructions set out in the service section of the relevant Service or Owner's Manual;
 - complies with clause 7 "Purchaser's Responsibilities" on page 26;
 - notifies Rinnai within 30 days of a defect occurring or, in the case of a latent defect, becoming apparent, that a claim is being made under this Warranty; and
 - provides, in support of the claim made under this Warranty, a Proof of Purchase.
- 3.2 This document (and any statutory consumer guarantees) represents the only Warranty given by Rinnai in respect of the Product. No other person or organisation is authorised to offer any alternative warranty on behalf of Rinnai.
- 3.3 If the date of purchase cannot be established to Rinnai's satisfaction, the date shall be deemed to be 2 months after the date of manufacture or the date of sale by Rinnai, whichever is the latter.
- 3.4 This warranty applies to Products which are manufactured on or after the date of publication of this warranty but before the next date of publication of this warranty.

4 EXCLUSIONS

- 4.1 This Warranty **DOES NOT** cover:
- damage, problems or failure resulting from improper operation and/or inadequate maintenance by the Purchaser (refer Purchaser's Responsibilities section below);
 - damage, problems or failure resulting from improper or faulty installation. The Product must be installed by a Qualified Installer in accordance with applicable regulations. Where applicable, Certificate(s) of Compliance must be obtained by the purchaser from the Qualified Installer and presented to the Authorised Service Representative;
 - damage, problems or failure caused by factors external to the Product including, but not limited to, faulty or poor external electrical wiring, incorrect or faulty power supply, voltage fluctuations, over voltage transients or electromagnetic interference, inadequate or faulty gas, drainage services, or water services, including water pressure, and non-potable water;
 - damage, problems or failure caused by acts of God, fire, wind, lightning, flood, storm, hail storm fallout, vandalism, earthquake, war, civil insurrection, misuse, abuse, negligence, accident, pests, animals, pets, vermin, insects, spiders/bugs or entry of foreign objects or matter into the Product such as dirt, debris, soot or moisture;
 - damage, problems or failure caused by environmental conditions including, but not limited to, excessive moisture, salt or other corrosive substances or atmospheric conditions;
 - Product which has been installed in a portable or mobile building, structure or application including, but not limited to, a caravan, boat or trailer;
 - Product which has been re-installed at a location other than the original site;
 - any consumable item supplied with the Product including, but not limited to, an air filter, battery, fan belt, igniter or cooler pad;
 - installation of third-party components that may be attached to the Product. These include, but are not limited to, control wiring, ducting, return air filter(s) grille, register, diffuser, zone motors, controls/thermostats, pipe work and fabricated or added components. These items remain solely the responsibility of the Qualified Installer;
 - installations where electrics/electronics may be subjected to moisture/chemicals (e.g. swimming pools or nurseries);
 - any repair, which is needed as a result of an accident, misuse, abuse or negligence;
 - Product that is utilised in an environment (indoor and outdoor) outside its specified operating range; and
 - fair wear and tear to the Product.
 - On-site labour warranty on portable (non-fixed installation) Products – In respect of such Products the Purchaser must return the Product to the supplier for repair or replacement).

5 LIMITATIONS

- 5.1 Third parties are often involved in providing advice to consumers about the climate control solutions best suited to the consumer's needs. Any advice or recommendations given by such parties, including advice about Product fitness for purpose and overall system design, sizing and application are not the responsibility of Rinnai. This includes but is not limited to the heat load calculations, airflow and system balancing.
- 5.2 This Warranty does not apply to any Product installed at an Installation Site which is outside Australia.
- 5.3 Except where inconsistent with the purchaser's statutory rights and the rights given by this Warranty, all liabilities of Rinnai for any direct, special, indirect or consequential loss or damage, any damage or expense for personal injury or any loss or destruction of property, arising directly or indirectly from the use or inability to use the Product or any of its parts and/or servicing the Product, are expressly excluded.

6 TRAVEL, TRANSPORT & ACCESS COSTS

- 6.1 The Purchaser must pay freight charges, in-transit insurance expenses and travelling costs for repairs/replacements under this Warranty, that are required to be performed 50km from the nearest Rinnai branch or Authorised Service Representative.
- 6.2 Subject to clause 6.3, Rinnai will pay freight charges, in-transit insurance expenses and travelling costs for repairs/replacements that are required to be performed less than 50km from the nearest Rinnai branch or Authorised Service Representative, subject to the following:
- Rinnai will arrange for such repairs/replacements and make any payment directly to the third party to provide the freight, in-transit insurance or travel services; or
 - if Rinnai considers appropriate, it will authorise the Purchaser in writing to pay for the relevant freight charges, in-transit insurance expenses or travelling costs and then, upon provision by the Purchaser to Rinnai of a tax invoice showing those costs have been incurred, reimburse the Purchaser for such costs which are within the terms of the authorisation. If the Purchaser pays for the relevant freight charges, in-transit insurance expenses or travelling costs without written authorisation from Rinnai, Rinnai will not reimburse the Purchaser for such costs.
- 6.3 The Purchaser must pay all costs and expenses in respect of:
- any service call out fee if the Product is not accessible for service
 - making the Product accessible for service, for example, restricted access or working at heights, or the labour cost for an additional person due to OHS requirements.
 - providing a safe working environment for installation, service, maintenance or repair of the Product;
 - any surcharge applicable in respect of supplying replacement parts outside Normal Business Hours; and
 - any other costs and expenses in relation to claiming the Warranty that is not covered by clause 6.2.

7 PURCHASER'S RESPONSIBILITIES

- 7.1 The Purchaser must operate and maintain the Product in accordance with the Operating Instructions and service maintenance schedule, including conducting an appropriate number of services to the unit during the Warranty period, based on usage and the usage environment including but not limited to;
- regularly cleaning the air filter(s) and replacing them where necessary;
 - replacing expired batteries or other consumables as required;
 - ensuring that the condensate drain is kept clean and clear of obstructions.

HOW TO MAKE A WARRANTY CLAIM:

If you wish to make a warranty claim in respect of any Portable Product, please return it to the place of purchase, or if that is not possible, contact Rinnai to enquire about alternative arrangements.

If you wish to make a warranty claim in respect of any fixed Product, please contact Rinnai on the details set out below to make arrangements for an Authorised Service Representative to inspect the product.

As per clause 2.6 of the Terms and Conditions of Warranty, purchasers are responsible for the costs of any repair and/or call out fee where, on inspection, the alleged defect is found by Rinnai's Authorised Service Representative not to be covered by this warranty or any statutory consumer guarantee applicable to the Product.

The Terms and Conditions of Warranty contain important information about your rights and obligations under this warranty. Please read them fully and carefully before making a claim.

NOTICE TO CONSUMERS UNDER AUSTRALIAN CONSUMER LAW

Our goods come with guarantees that cannot be excluded under the Australian Consumer Law. You are entitled to a replacement or refund for a major failure and compensation for any other reasonably foreseeable loss or damage. You are also entitled to have the goods repaired or replaced if the goods fail to be of acceptable quality and the failure does not amount to a major failure.

Our services come with guarantees that cannot be excluded under the Australian Consumer Law. For a major failure with the service, you are entitled to cancel your service contract with us and obtain a refund for the unused portion, or to compensation for its reduced value. You are also entitled to be compensated for any other reasonably foreseeable loss or damage. If the failure does not amount to a major failure you are entitled to have problems with the service rectified in a reasonable time and, if this is not done, to cancel your contract and obtain a refund for the unused portion of the contract.

The benefits provided by this Warranty are in addition to any other rights and remedies available to a consumer under the Australian Consumer Law and any other law which may apply to the goods and or services.

Rinnai Australia Pty Ltd

ABN 74 005 138 769 | AU45204

100 Atlantic Drive, Keysborough, Victoria 3173
P.O. Box 460, Braeside, Victoria 3195
Tel: (03) 9271 6625

National Help Line

Tel: 1300 555 545*

Monday to Friday, 8.00 am to 5.00 pm EST.

**Cost of a local call may be higher from a mobile phone.
(National calls from public phones in Australia are free.)*

For further information visit www.rinnai.com.au
or email enquiry@rinnai.com.au

Rinnai has a Service and Spare Parts network with personnel who are fully trained and equipped to give the best service on your Rinnai appliance. If your appliance requires service, please call our National Help Line. Rinnai recommends that this appliance be serviced once a year.

With our policy of continuous improvement, we reserve the right to change, or discontinue at any time, specifications or designs without notice.