

MODELS – Rinnai Inverter Multi Split System

Outdoor	Indoor Hi-Wall	Indoor Ducted	Indoor Cassette	Indoor Console
MON3H07B	HINRP20MB	DINSD26MB	CIN020RMB	FINRP50MB
MON4H09B	HINRP26MB	DINSD35MB	CIN026RMB	
MON5H11B	HINRP35MB	DINSD50MB	CIN035RMB	
MON5H13B	HINRP50MB	DINSD70MB	CIN050RMB	
MON6H18B	HINRP60MB HINRP70MB HINRP80MB			

REFRIGERANT
R32

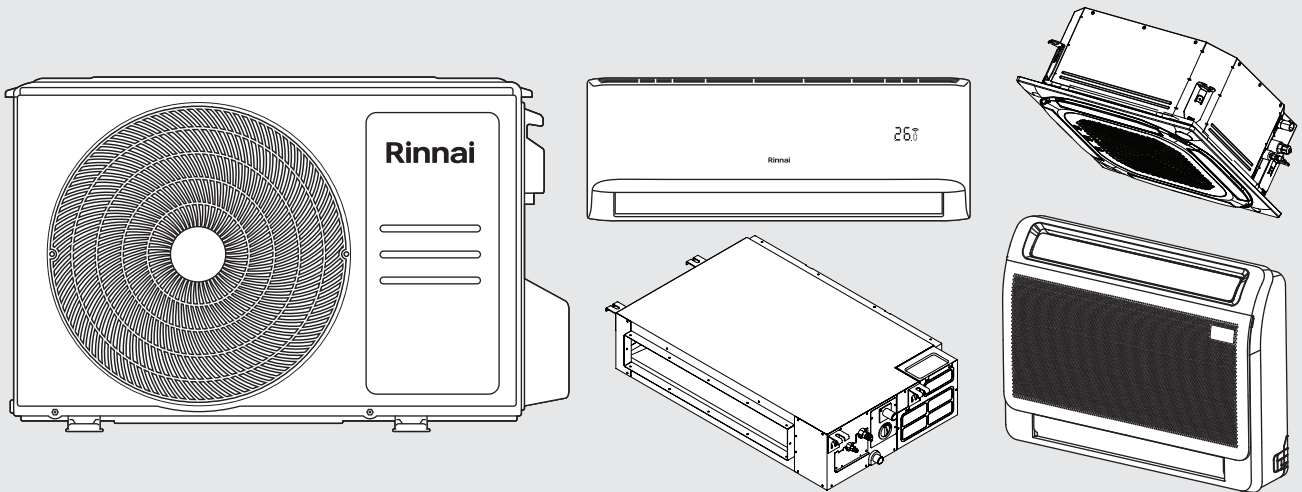

Multi Split Type Air Conditioner Installation Manual

Rinnai



Read this manual and **SAFETY MANUAL** (if any) carefully before installing or operating your new air conditioning unit. Make sure to save this manual for future reference.

Please check the applicable models, technical data and manufacturer information from the “Operation Manual” in the packaging of the outdoor unit.

This appliance must be installed in accordance with:

- Manufacturer’s Installation Instructions
- Current AS/NZS 3000, AS/NZS 5149, AS/NZS 5141
- Local Regulations and Municipal Building Codes including local OH&S requirements

This appliance must be installed, maintained and removed only by an Authorised Person.

For continued safety of this appliance it must be installed and maintained in accordance with the manufacturer’s instructions.



The design and specifications are subject to change without prior notice for product improvement. Consult with the Dealer or manufacturer for details.

Any updates to the manual will be uploaded to the service website, please check for the latest version.



PLEASE REFER TO ANY OPERATING MANUALS AND USER OPERATING GUIDES ACCOMPANYING ANCILLARY EQUIPMENT (WHERE FITTED)

TABLE OF CONTENTS

Warnings and Important Information	5
Safety Precautions	7
Disposal Guidelines	9
Specifications	10
Installing Multiple Units	10
Technical Specifications	11
Indoor Installation	13
Installation Diagram	13
Wall Mounted Installation (Indoor)	14
Selecting Installation Position	14
Indoor Unit Wall Mounted Accessories	15
Indoor Unit Installation (Wall Mounted Type)	16
Piping and Wrapping	17
Indoor Unit Installation	17
Indoor Unit Ducted Accessories	18
Safety Precautions	19
Ducted Indoor Unit Installation	20
Service Access	20
Mounting Indoor Unit	23
Drainpipe Installation	26
Indoor Drainpipe Installation	26
Drainage Test	28
System Settings	29
Indoor Cassette Installation	30
Indoor Compact Cassette Accessories	30
Indoor Compact Cassette Installation Instructions	31
Indoor Drainpipe Installation	35
Panel Installation for Compact Cassette Models	37
Indoor Floor Console Installation	40
Indoor Floor Console Installation Instructions	40
Bottom mounting plate installation	42
Outdoor Unit Installation	46
Outdoor Unit Accessories	46
Optional Accessories	46

TABLE OF CONTENTS

Installation Summary	47
Installation Instructions – Outdoor Unit	48
Special Considerations For Extreme Weather	49
Unit Mounting Dimensions	51
Rows of Series Installation	51
Drilling Hole In Wall	51
When selecting a 7.0kW & 8.0kW Indoor Unit	52
Refrigerant Piping Connection	53
Wiring	56
Outdoor Unit Wiring	57
Outdoor Unit Wiring Diagram	59
Pressure & Leak Test	61
Dry Nitrogen Pressure Test	61
Leak Testing Instructions	61
Air Evacuation	62
Preparations and Precautions	62
Evacuation Instructions	62
Adding Refrigerant	63
Safety And Leakage Check	64
Test Run	65
Before Test Run	65
Test Run Instructions	65
Automatic Correction Function	66
Automatic Wiring/Piping Correction Function	66
Commissioning	67
Commissioning Checklist	67
Contacts	68

WARNINGS AND IMPORTANT INFORMATION



READ ALL INSTRUCTIONS BEFORE USING THE APPLIANCE

Always comply with the following precautions to avoid dangerous situations and to ensure optimum performance.

Failure to carefully read and follow all instructions in this manual can result in equipment malfunction, property damage, personal injury and/or death.

WARNINGS: WHEN IGNORED, CAN RESULT IN SERIOUS INJURY OR DEATH.

CAUTIONS: WHEN IGNORED, CAN RESULT IN MINOR INJURY OR PRODUCT DAMAGE.



REGULATORY / INSTALLATION

This appliance shall be installed in accordance with:

- Manufacturer's Installation Instructions.
- Current AS/NZS 3000, AS/NZS 5141, AS/NZS 5149, AS/NZS 3500 National Plumbing & Drainage, HB276 - A Guide to good practice for energy efficient installation.
- Local Regulations and Municipal Building Codes including local OH&S requirements.
- This appliance must be installed, maintained and removed by an Authorised Person.

For continued safety of this appliance it must be installed and maintained in accordance with the manufacturers instructions.

This appliance uses R32 refrigerant.

This appliance is heavy, use 2 people or mechanical lifting device. Improper lifting may result in serious injury.

Take care when opening or unpacking this appliance. Failure to do so may result in serious injury or product failure.

DO NOT modify the electrical wiring of this appliance. If the control power wiring is damaged or deteriorated then it must be replaced by an authorised person. Failure to do so may result in electric shock, fire, serious injury or product failure.

DO NOT install the air conditioner on an unstable or non level surface or where there may be a danger of it falling. It may result in death, serious injury, or product failure.

DO NOT install the outdoor unit where noise may cause nuisance.

DO NOT install the outdoor unit where it will be exposed to sea wind (salt spray) as this will reduce durability.

This appliance can be used by children aged from 8 years and above and persons with reduced physical, sensory or mental capabilities or lack of experience and knowledge if they have been given supervision or instruction concerning use of the appliance in a safe way and understand the hazards involved. Children shall not play with the appliance. Cleaning and user maintenance shall not be made by children without supervision. Refer to AS/NZS Standards and regulations.

This appliance is not intended for use by persons(including children) with reduced physical, sensory or mental capabilities, or lack of experience and knowledge, unless they have been given supervision or instruction concerning use of the appliance by a person responsible for their safety. Children should be supervised to ensure that they do not play with the appliance.



MANDATORY INSPECTION PRIOR TO INSTALLATION

Immediately report any damage or discrepancies to the Supplier of the appliance. This appliance was inspected and tested at the time of manufacture and packaging, and released for transportation without known damage. Upon receipt, inspect the exterior for evidence of rough handling in shipment. Ensure that the appliance is labelled correctly for the gas and electrical supply, and/or other services it is intended to be connected to.

For safety and warranty purposes, appliances that may be damaged or incorrect **MUST NOT** be installed or operated under any circumstances. Installation of damaged or incorrect appliances may contravene local government regulations. Rinnai disclaims any liability or responsibility whatsoever in relation to the installation or operation of damaged or incorrect appliances.



WARNINGS FOR PRODUCT USE

- If an abnormal situation arises (like a burning smell), immediately turn off the unit and disconnect the power. Call your dealer for instructions to avoid electric shock, fire or injury.
- **DO NOT** insert fingers, rods or other objects into the air inlet or outlet. This may cause injury, since the fan may be rotating at high speeds.
- **DO NOT** use flammable sprays such as hair spray, lacquer or paint near the unit. This may cause fire or combustion.
- **DO NOT** operate the air conditioner in places near or around combustible gases. Emitted gas may collect around the unit and cause explosion.
- **DO NOT** operate your air conditioner in a wet room such as a bathroom or laundry room. Too much exposure to water can cause electrical components to short circuit.
- **DO NOT** expose your body directly to cool air for a prolonged period of time.
- **DO NOT** allow children to play with the air conditioner. Children must be supervised around the unit at all times.
- If the air conditioner is used together with burners or other heating devices, thoroughly ventilate the room to avoid oxygen deficiency.
- In certain functional environments, such as kitchens, server rooms, etc., the use of specially designed air-conditioning units is highly recommended.



ELECTRICAL WARNINGS

- If any electrical cables are damaged, they **MUST** be replaced by a suitably qualified and trained service person in order to avoid any potential hazards.
- The product **MUST** be properly earthed at the time of installation, or electrical shock may occur.
- For all electrical work, follow all local and national wiring standards, regulations, and the Installation Manual. Connect cables tightly, and clamp them securely to prevent external forces from damaging the terminal. Improper electrical connections can overheat and cause fire, and may also cause shock. All electrical connections must be made according to the Electrical Connection Diagram located on the panels of the indoor and outdoor units.
- Appropriately specified and sized cables **MUST** be used, ensure all connections are tight. Clamp all cables sufficiently so that they cannot be pulled loose or disconnected.
- All wiring **MUST** be properly arranged to ensure that the control board cover can close properly. If the control board cover is not closed properly, it can lead to corrosion and cause the connection points on the terminal to heat up, catch fire, or cause electrical shock.
- A correctly specified and sized circuit breaker **MUST** be installed in accordance with all local and national wiring standards. A dedicated, independent electrical circuit is required for the system.
- **DO NOT** share the electrical outlet with other appliances. Improper or insufficient power supply can cause fire or electrical shock.
- If connecting power to fixed wiring, an all-pole disconnection device which has at least 3mm clearances in all poles, and have a leakage current that may exceed 10mA, the residual current device (RCD) having a rated residual operating current not exceeding 30mA, and disconnection must be incorporated in the fixed wiring in accordance with wiring rules.



Turn off the air conditioner and switch mains power off if you are not going to use it for a long time.

- Turn off and unplug the unit during storms.
- Make sure that water condensation can drain unhindered from the unit.
- Do not operate the air conditioner with wet hands. This may cause electric shock.
- Do not use device for any other purpose than its intended use.
- Do not climb onto or place objects on top of the outdoor unit.
- Do not allow the air conditioner to operate for long periods of time with doors or windows open, or if the humidity is very high.

SAFETY PRECAUTIONS



PRODUCT INSTALLATION WARNINGS

- Installation must be performed by an authorised dealer or specialist. Defective installation can cause water leakage, electrical shock, or fire.
- Installation must be performed according to the installation instructions and installed by an Authorised Person only. Improper installation can cause water leakage, electrical shock, or fire.
- Contact an authorised service technician for repair or maintenance of this unit. This appliance shall be installed in accordance with current wiring regulations.
- Only use the included accessories, parts, and specified parts for installation. Using non-standard parts can cause water leakage, electrical shock, fire, and can cause the unit to fail.
- Install the unit in a firm location that can support the unit's weight. If the chosen location cannot support the unit's weight, or the installation is not done properly, the unit may drop and cause serious injury and damage.
- Install drainage piping according to the instructions in this manual. Improper drainage may cause water damage to your home and property.
- For units that have an auxiliary electric heater, do not install the unit within 1 metre of any combustible materials.
- **DO NOT** install the unit in a location that may be exposed to combustible gas leaks. If combustible gas accumulates around the unit, it may cause fire.
- **DO NOT** install the indoor unit under a floor or beneath a deck, to be installed in a roof space only.
- **DO NOT** turn on the power until all work has been completed.
- When moving or relocating the air conditioner, consult experienced service technicians for disconnection and reinstallation of the unit.
- How to install the appliance to its support, please read the information for details in "indoor unit installation" and "outdoor unit installation" sections.



FLUORINATED GASES

- This air-conditioning unit contains fluorinated greenhouse gases. For specific information on the type of gas and the amount, please refer to the relevant label on the unit itself or the "Owner's Manual" in the packaging of the outdoor unit.
- Installation, service, maintenance and repair of this unit must be performed by a certified technician.
- Product uninstallation and recycling must be performed by a certified technician.
- For equipment that contains fluorinated greenhouse gases in quantities of 5 tonnes of CO₂ equivalent or more, but less than 50 tonnes of CO₂ equivalent, if the system has a leak-detection system installed, it must be checked for leaks at least every 24 months.
- When the unit is checked for leaks, proper record-keeping of all checks is strongly recommended



FUSE SPECIFICATIONS

The air conditioner's circuit board (PCB) is designed with a fuse to provide overcurrent protection. The specifications of the fuse are printed on the circuit board, such as:

- T5A/250VAC, T10A/250VAC, etc.
- T20A/250VAC(<=7kW units), T30A/250VAC(>7kW units)

NOTE: For the units with R32, only the blast-proof ceramic fuse can be used.



A NOTE ON ILLUSTRATIONS

The illustrations used in this manual are for explanatory purposes only and the shape of your indoor unit may vary slightly from that which is shown in this manual.



USING R32 REFRIGERANT

When flammable refrigerant are employed, appliance shall be stored in a well-ventilated area where the room size corresponds to the room area as specified for operation.

Appliance shall be installed, operated and stored in a room with a floor area larger than X m². Appliance **MUST NOT** be installed in a unventilated space, if that space is smaller than X m².



REFRIGERANT

This appliance uses R32 (difluoromethane) refrigerant, which is a flammable gas class A2L according to AS 5149.1 and must be handled by a refrigeration mechanic with an appropriate Australian refrigerant handling licence.



WARNING Risk of fire / flammable material. If the refrigerant is leaked, together with an external ignition source, there is a possibility of ignition.



Read the OPERATING INSTRUCTIONS carefully before operation.



Service personnel are required to carefully read the OPERATING INSTRUCTIONS and INSTALLATION MANUAL before operation.



Further information is available in the OPERATING INSTRUCTIONS, INSTALLATION MANUAL, and the like.

Certain levels of refrigerant require minimum room sizes. Please ensure that these minimum room sizes are adhered to for standard installations (up to 15m pipe length). If larger refrigerant charges than standard are used then please consult AS/NZS 60335.2.40 to determine the safe minimum floor area for the installation.

Make sure that the area has been made safe by having suitable ventilation and is free from ignition sources before charging or releasing the charge of R32.

Minimum Room Size

Amount of refrigerant to be charged (kg)	Installation height (m)	Minimum room area (m ²)	Amount of refrigerant to be charged (kg)	Installation height (m)	Minimum room area (m ²)
1.0	0.6 /1.8 /2.2	9 /1 /1	1.95	0.6 /1.8 /2.2	33 /4 /2.5
1.05	0.6 /1.8 /2.2	9.5 /1.5 /1	2.0	0.6 /1.8 /2.2	34.5 /4 /3
1.1	0.6 /1.8 /2.2	10.5 /1.5 /1	2.05	0.6 /1.8 /2.2	36 /4 /3
1.15	0.6 /1.8 /2.2	11.5 /1.5 /1	2.1	0.6 /1.8 /2.2	38 /4.5 /3
1.2	0.6 /1.8 /2.2	12.5 /1.5 /1	2.15	0.6 /1.8 /2.2	40 /4.5 /3
1.25	0.6 /1.8 /2.2	13.5 /1.5 /1	2.2	0.6 /1.8 /2.2	41.5 /5 /3.5
1.3	0.6 /1.8 /2.2	14.5 /2 /1.5	2.25	0.6 /1.8 /2.2	43.5 /5 /3.5
1.35	0.6 /1.8 /2.2	16 /2 /1.5	2.3	0.6 /1.8 /2.2	45.5 /5 /3.5
1.4	0.6 /1.8 /2.2	17 /2 /1.5	2.35	0.6 /1.8 /2.2	47.5 /5.5 /4
1.45	0.6 /1.8 /2.2	18 /2 /1.5	2.4	0.6 /1.8 /2.2	49.5 /5.5 /4
1.5	0.6 /1.8 /2.2	19.5 /2.5 /1.5	2.45	0.6 /1.8 /2.2	51.5 /6 /4
1.55	0.6 /1.8 /2.2	21 /2.5 /2	2.5	0.6 /1.8 /2.2	54 /6 /4
1.6	0.6 /1.8 /2.2	22 /2.5 /2	2.55	0.6 /1.8 /2.2	56 /6.5 /4.5
1.65	0.6 /1.8 /2.2	23.5 /3 /2	2.6	0.6 /1.8 /2.2	58 /6.5 /4.5
1.7	0.6 /1.8 /2.2	25 /3 /2	2.65	0.6 /1.8 /2.2	60.5 /7 /4.5
1.75	0.6 /1.8 /2.2	26.5 /3 /2	2.7	0.6 /1.8 /2.2	63 /7 /5
1.8	0.6 /1.8 /2.2	28 /3.5 /2.5	2.75	0.6 /1.8 /2.2	65 /7.5 /5
1.85	0.6 /1.8 /2.2	29.5 /3.5 /2.5	2.8	0.6 /1.8 /2.2	67.5 /7.5 /5
1.9	0.6 /1.8 /2.2	31 /3.5 /2.5	2.85	0.6 /1.8 /2.2	70 /8 /5.5

- All minimum room sizes in the above table are calculated on the base charge provided with the outdoor unit.

- Mechanical connectors used indoors shall comply with ISO 14903.
- This appliance shall be installed in accordance with AS/NZS 5149.
- When mechanical connectors are reused, sealing parts shall be renewed.
- When flared joints are reused, the flare part shall be re-fabricated.

DISPOSAL GUIDELINES

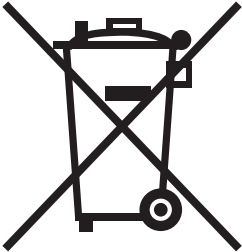

This appliance contains refrigerant and other potentially hazardous materials. When disposing of this appliance, the law requires special collection and treatment. **DO NOT** dispose of this product as household waste or unsorted municipal waste.



Special notice – Disposing of this appliance in the forest or other natural surroundings endangers your health and is bad for the environment. Hazardous substances may leak into the ground water and enter the food chain.



CLEANING AND MAINTENANCE WARNINGS

- Turn off the device and switch the mains power off before cleaning. Failure to do so can cause electric shock
- **DO NOT** clean the air conditioner with excessive amounts of water.
- **DO NOT** clean the air conditioner with combustible cleaning agents. Combustible cleaning agents can cause fire or deformation

SPECIFICATIONS

INSTALLING MULTIPLE UNITS

Number of units that can be used together	Connected units	1-6 units
Compressor stop/start frequency	Stop time	3 min or more
Power Source Voltage	Voltage fluctuation	Within $\pm 10\%$ of rated voltage
	Voltage drop during start	Within $\pm 15\%$ of rated voltage
	Interval unbalance	Within $\pm 3\%$ of rated voltage

	Unit / m			
	3 Head	4 Head	5 Head	6 Head
Max. length for all rooms	60	80	80	80
Max. length for one indoor unit	30	35	35	35
Max. height difference between indoor and outdoor unit	15	15	15	15
Max. height difference between indoor units	10	10	10	10



For the units adopt quick connectors, no more than two pipes can be connected, and the maximum length for each pipe is 7.5m.

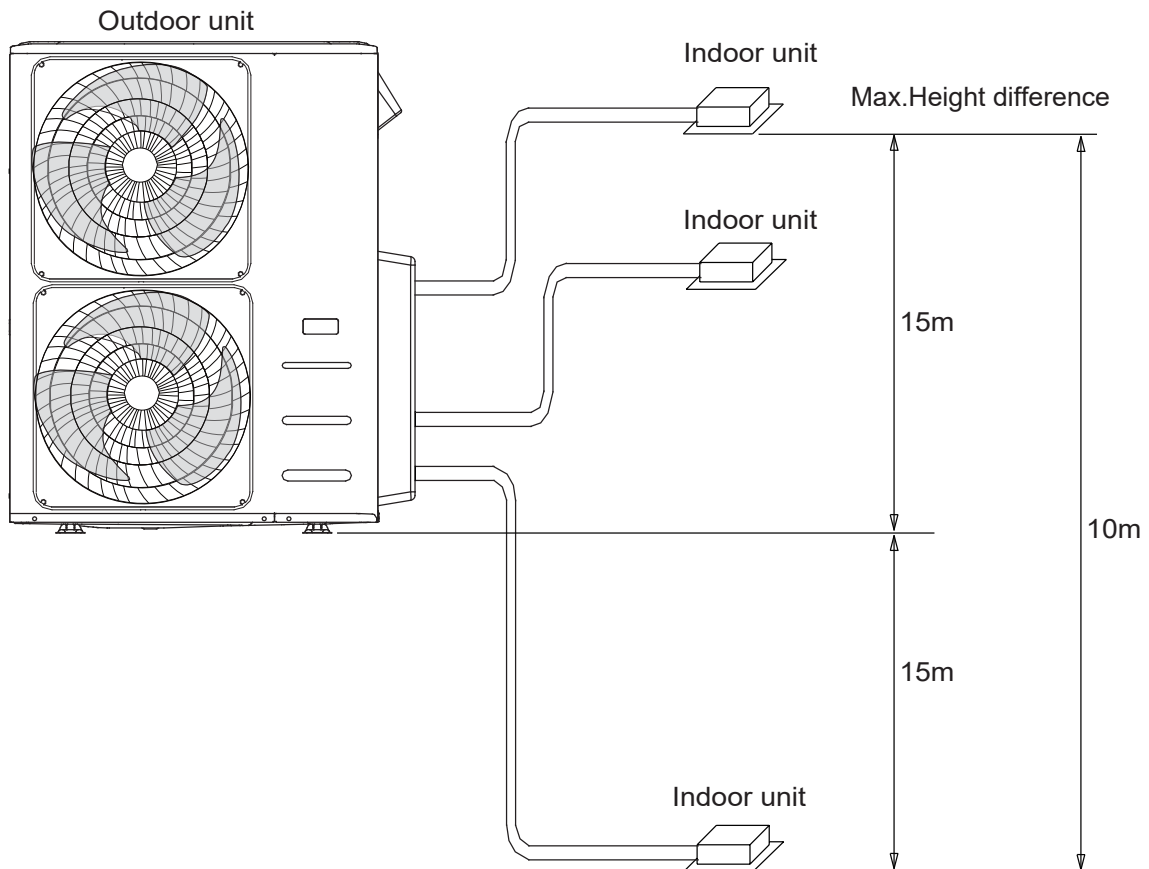

TECHNICAL SPECIFICATIONS

MULTI OUTDOOR UNIT			MON3H07B	MON4H09B	MON5H11B	MON5H13B	MON6H18B
Number of connected Indoor Units		Qty	3	4	5	5	6
Power Supply (To Outdoor Unit)		V-Ph-Hz	220-240-1-50				
Cooling	Rated Capacity (Range)	kW	7.5 (1.7-9.8)	9 (1.7-11.5)	11.5 (2.6-11.7)	13.0 (2.6-14.6)	17.5 (4.57-18.5)
	Rated Input Power	kW	1.98	2.07	3.1	3.8	5.0
	Rated Input Current	A	8.9	10.09	15.65	16.87	22.80
	AEER	W/W	3.71	4.24	3.64	3.37	3.45
Heating	Rated Capacity (Range)	kW	7.4 (1.8-9.6)	9.3 (1.8-12.0)	12.3 (2.6-12.3)	13.5 (2.6-15.2)	20.0 (4.98-20.7)
	Rated Input Power	W	1.59	2.07	3.1	3.22	5.10
	Rated Input Current	A	7.28	10.3	14.19	14.31	24.00
	ACOP	W/W	4.54	4.38	3.89	4.11	3.87
Maximum Input Current		A	17.5	19	22	30	33
Recommended Circuit Breaker		A	25	25	25	35	40
Compressor		Type	Inverter Twin Rotary				
Sound Power Level		dB(A)	66	68.4	67.9	72	71
Dimensions	Net (W x D x H)	mm	890 x 342 x 673	946 x 410 x 810	946 x 410 x 810	980 x 451 x 975	952 x 415 x 1333
	Gross (W x D x H)	mm	1030 x 438 x 790	1090 x 500 x 935	1090 x 500 x 935	1145 x 500 x 1090	1095 x 495 x 1480
	Net / Gross Weight	kg	48.0 / 61.5	66.2 / 83.0	76.0 / 93.0	91.0 / 106.4	110.6 / 124.9
Refrigerant Type			R32				
Refrigerant Piping	Connection Size: Liquid Line	mm	3 x Φ6.35	4 x Φ6.35	5 x Φ6.35	5 x Φ6.35	6 x Φ6.35
	Connection Size: Gas	mm	3 x Φ9.52	3 x Φ9.52 + 1 x Φ12.7	4 x Φ9.52 + 1 x Φ12.7	3 x Φ9.52 + 2 x Φ12.7	4 x Φ9.52 + 2 x Φ12.7
	Maximum Total System Pipe Length	m	60	80	80	80	80
	Pre-Charged Length	m	22.5	30	37.5	37.5	45
	Maximum Length Per Indoor Unit	m	30	35	35	35	35
	Maximum Vertical Separation Outdoor Unit ABOVE Indoor Unit	m	10	10	10	10	10
	Maximum Vertical Separation Outdoor Unit BELOW Indoor Unit	m	15	15	15	15	15
	Maximum Height Difference Between Indoor Units	m	10	10	10	10	10
	Factory Pre-charge	g	1850	2400	2590	2950	4300
Ambient Temperature Limits	Cooling	°C	-15~50				
	Heating	°C	-25~30				

INDOOR - PB Series Hi-Wall Split System		HINRP20MB	HINRP26MB	HINRP35MB	HINRP50MB	HINRP60MB	HINRP70MB	HINRP80MB	
Power Supply		V-Ph-Hz	220-240 - 1 - 50						
Cooling	Rated Capacity	kW	2	2.65	3.5	5.0	6.0	7.15	7.8
	Rated Power Input	W	30	30	30	56	56	120	120
	Rated Current	A	0.17	0.17	0.17	0.33	0.33	0.62	0.62
Heating	Rated Capacity	kW	2.25	2.7	3.8	5.4	6.5	7.8	8.3
	Rated Power Input	W	30	30	30	56	56	120	120
	Rated Current	A	0.17	0.17	0.17	0.33	0.33	0.62	0.62
Air Flow (Turbo / Hi / Med / Lo / Min)	L/s	153 / 128 / 94 / 75 / 47	175 / 139 / 100 / 83 / 56	183 / 147 / 106 / 86 / 58	264 / 222 / 167 / 139 / 89	264 / 222 / 167 / 139 / 89	382 / 303 / 250 / 229 / 147	382 / 303 / 250 / 229 / 147	
Sound Pressure Level @ 1m (Turbo / Hi / Med / Lo / Min)	dB(A)	43 / 38 / 31 / 30 / 25	46 / 39 / 32 / 30 / 24	46 / 39 / 32 / 30 / 24	47 / 44 / 38 / 34 / 28	47 / 44 / 38 / 34 / 28	57 / 45 / 39 / 33 / 29	57 / 45 / 39 / 33 / 29	
Air Swing Louvres	Direction	4-way swing							
Dimensions	Net (W x D x H)	mm	729 x 200 x 292	802 x 200 x 295	802 x 200 x 295	971 x 228 x 321	971 x 228 x 321	1082 x 234 x 337	1082 x 234 x 337
	Packing (W x D x H)	mm	790 x 273 x 370	875 x 288 x 375	875 x 288 x 375	1045 x 308 x 405	1045 x 308 x 405	1155 x 415 x 318	1155 x 415 x 318
	Net / Gross Weight	kg		8.5 / 11.5	8.5 / 11.5	11.1 / 15.2	11.1 / 15.2	13.5 / 17.8	13.5 / 17.8
Refrigerant Pipe Size: Liquid / Gas	mm	6.35mm / 9.52mm	6.35mm / 9.52mm	6.35mm / 9.52mm	6.35mm / 12.7mm	6.35mm / 12.7mm	6.35mm / 15.9mm	6.35mm / 15.9mm	
Controller	Type	Wireless Remote Control							
Operating Range	Cooling	°C	16~32						
	Heating	°C	0~30						
Wi-Fi Compatibility		Standard							

TECHNICAL SPECIFICATIONS

SLIM DUCTED		DINSD26MB	DINSD35MB	DINSD50MB	DINSD70MB	
Power Supply		V-Ph-Hz	220-240-1-50			
Cooling	Rated Capacity	kW	2.6	3.5	5.2	7.1
	Rated Input Power	W	180	185	200	200
	Rated Input Current	A	1.1	1.1	1.3	1.3
Heating	Rated Capacity	kW	2.9	3.8	5.5	7.3
	Rated Input Power	W	180	185	200	200
	Rated Input Current	A	1.1	1.1	1.3	1.3
Airflow (Hi / Med / Lo)		L/s	138 / 94 / 63	166 / 133 / 83	253 / 196 / 143	341 / 287 / 229
Maximum External Static Pressure (Hi)		Pa	60	60	100	160
Sound Pressure (Hi / Med / Lo) @1.0m		dB(A)	40 / 34 / 27	40 / 34 / 27	40 / 34 / 27	41 / 38 / 33
Dimensions	Net (W x D x H)	mm	700 x 506 x 200	700 x 506 x 200	880 x 674 x 210	1100 x 774 x 249
	Gross (W x D x H)		860 x 540 x 285	860 x 540 x 285	1105 x 725 x 285	1305 x 805 x 315
	Net / Gross Weight	kg	18 / 22	18 / 22	24 / 29	32 / 39
	Supply Air Duct Connection (W x H)	mm	537 x 152	537 x 152	706 x 136	926 x 175
	Return Air Duct Connection (W x H)		599 x 186	599 x 186	782 x 190	1001 x 228
	Refrigeration Pipe Size: Liquid / Gas		Φ6.35 / Φ9.52	Φ6.35 / Φ9.52	Φ6.35 / Φ9.52	Φ9.52 / Φ15.9
Condensate Drain Pump Connection		mm	ODΦ25mm			
Controller		Type	Wired Controller - 12m Cable			
Operating Range	Cooling	°C	17-32			
	Heating		0-30			
Wi-Fi Compatibility			Optional			

COMPACT CASSETTES		CIN020RMB	CIN026RMB	CIN035RMB	CIN050RMB	
Fascia Panel		Model No.	CINFASMB			
Power supply		V-Ph-Z	220-240-1-50			
Cooling	Rated Capacity	kW	2.00	2.60	3.50	5.30
	Rated Input Power	W	60	60	70	75
	Rated Input Current	A	1.1	1.2	1.2	1.2
Heating	Rated Capacity	kW	2.30	2.90	3.50	5.50
	Rated Input Power	W	60	60	70	75
	Rated Input Current	A	1.1	1.2	1.2	1.2
Airflow (Hi / Med / Lo)		L/s	139 / 128 / 111	139 / 128 / 111	172 / 144 / 92	183 / 150 / 83
Sound Pressure Level @1.0m (Hi/Med/Lo)		dB(A)	40 / 37 / 27	40 / 37 / 27	42 / 38 / 31	44 / 41 / 31.5
Dimensions	Net - Body (W x D x H)	mm	570 x 570 x 245	570 x 570 x 245	570 x 570 x 245	570 x 570 x 245
	Gross - Body (W x D x H)		715 x 640 x 295	715 x 640 x 295	715 x 640 x 295	715 x 640 x 295
	Net - Fascia (W x D x H)	kg	620 x 620 x 50			
	Gross - Fascia (W x D x H)		715 x 700 x 115			
	Net / Gross Weight - Body		14.6 / 17.5	14.6 / 17.5	14.6 / 17.5	14.6 / 17.5
	Net / Gross Weight - Fascia	mm	2.7/4.3			
	Refrigeration Pipe Size: Liquid / Gas		Φ6.35 / Φ9.52	Φ6.35 / Φ9.52	Φ6.35 / Φ9.52	Φ6.35 / Φ12.7
	Condensate Drain Pump Connection		Φ25	Φ25	Φ25	Φ25
Controller		Type	Remote controller			
Operating Range	Cooling	°C	16-32			
	Heating		0-30			
Wi-Fi Compatibility			Standard			

FLOOR CONSOLE		FINRP50B	
Power supply		V-Ph-Hz	220-240V,1Ph,50Hz
Cooling (Standard conditions)	Rated Capacity	kW	4.90
	Rated Power Input	W	80
	Rated Current	A	0.70
Heating (Standard conditions)	Rated Capacity	kW	5.50
	Rated Power Input	W	80
	Rated Current	A	0.7
Sound Power Level		dB(A)	54
Indoor unit	Dimension (W x D x H)	mm	794 x 200 x 621
	Packing (W x D x H)	mm	865 x 280 x 719
	Net/Gross Weight	kg	14.9 / 18.8
Wi-Fi Compatibility			Standard

20 August 2024

INDOOR INSTALLATION

INSTALLATION DIAGRAM

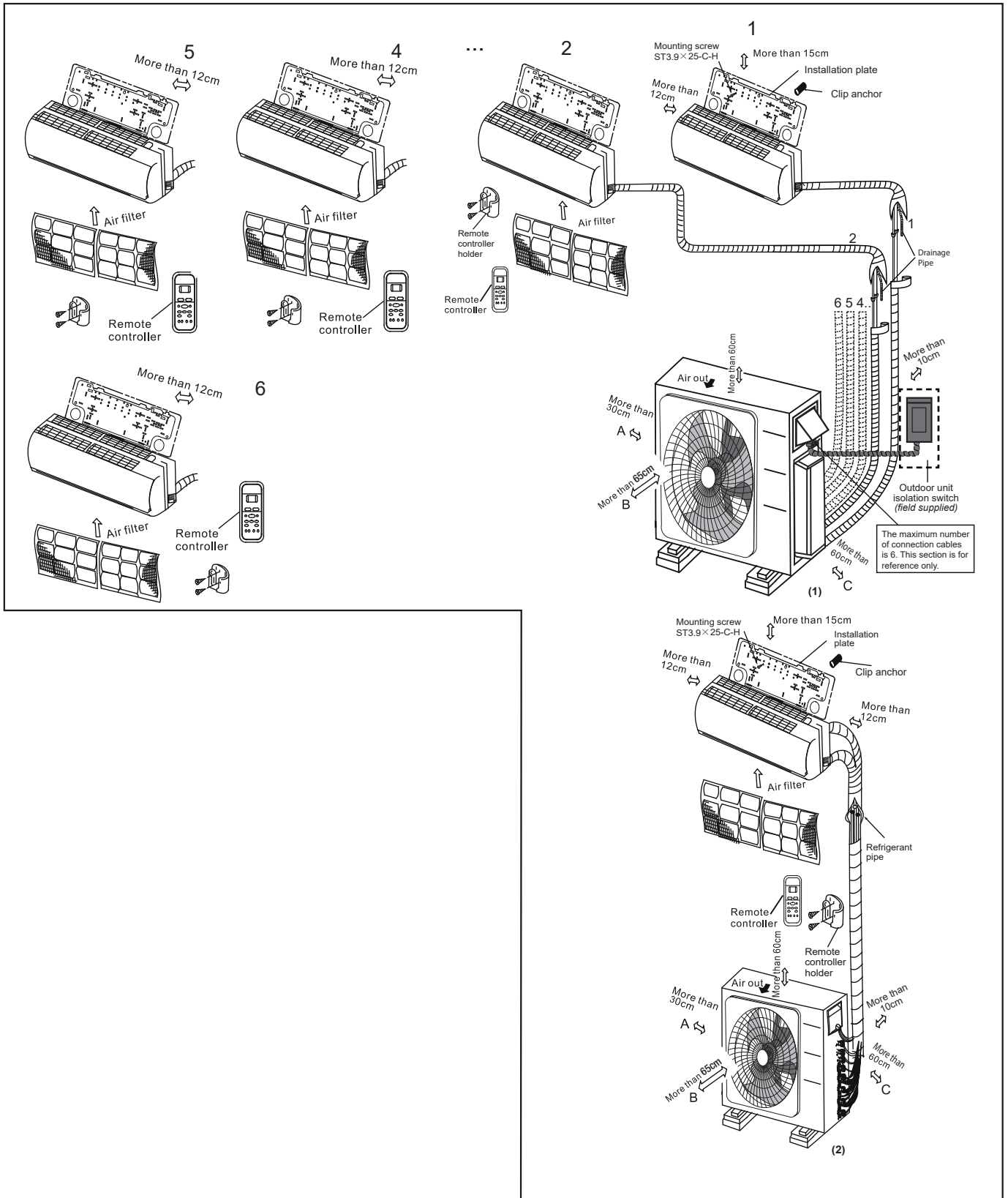



- To prevent wall damage, use a stud finder to locate studs.
- A minimum pipe run of 3 metres is required to minimise vibration and excessive noise.
- Two of the A, B and C air circulation pathways must be free from obstructions at all times.
- This illustration is for demonstration purposes only.
- The actual shape of your air conditioner may be slightly different.
- Copper lines must be independently insulated.



The installation must be performed in accordance with the requirement of local and national standards. The installation may be slightly different in different areas.

WALL MOUNTED INSTALLATION (INDOOR)

WALL MOUNTED - also refer to the Installation Manual accompanying the Wall Mounted Unit.

SELECTING INSTALLATION POSITION

Read completely, then follow step by step.





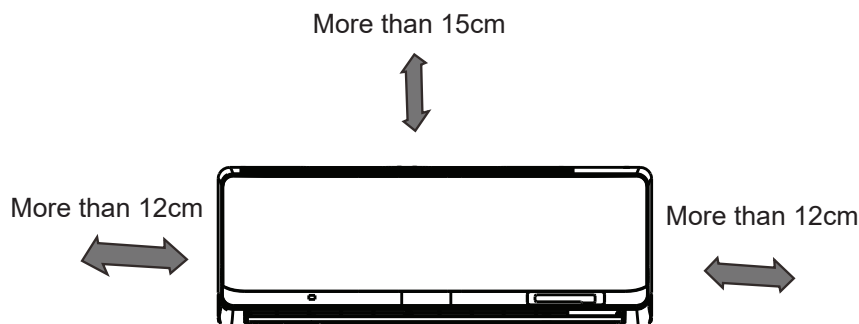

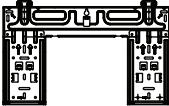

Indoor Unit

- Do not expose the indoor unit to external heat or steam.
- Select a position where there are no obstacle in front or around the unit.
- Make sure that the condensate drain and pipework can be conveniently routed.
- Do not install near doorways and kitchen.
- Ensure that the clearance to the left and the right of the unit is more than 12cm.
- Use a stud finder to locate studs for secure mounting and prevent damage to the wall.
- The indoor unit should be installed allowing a minimum clearance of 15cm from the ceiling above.
- Any variations in pipe length may require adjustment to the refrigerant charge.
- Install away from direct sunlight . The sun may fade the plastic cabinet and affect its appearance.
- If unavoidable, adequate sunlight prevention should be taken into consideration.



INDOOR UNIT WALL MOUNTED ACCESSORIES

The Air Conditioning system comes with the following accessories. Use all of the installation parts and accessories to install the air conditioner. Improper installation may result in water leakage, electrical shock and fire, or cause the equipment to fail.

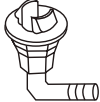
Name	Shape	Quantity	
Mounting plate		1	
Clip anchor		5	
Mounting plate fixing screw ST3.9 X 25		5	
Remote controller		1	
Fixing screw for remote controller holder ST2.9 x 10		2	Optional Parts
Remote controller holder		1	
Dry battery AAA.LR03		2	
Seal		1 (for cooling and heating models only)	
Drain joint			

INDOOR UNIT INSTALLATION (WALL MOUNTED TYPE)

1. Fit the Installation Plate

- Fit the installation plate horizontally on a structural part of the wall with required space around the installation plate.
- If the wall is made of brick, concrete or the like, drill 5mm diameter holes in the wall. Insert anchor plugs for the appropriate mounting screws.
- Fit the installation plate on the wall with five or eight type A screws.

2. Drill pipework hole in the wall

- Determine hole positions according to diagram detailed in diagram below. Drill one (1) hole slanting slightly to outdoor side.
- Always use wall hole conduit when drilling metal grid, metal plate or the like.

3. Condensate drain and refrigerant pipe installation Drainage

- Run the condensate drain hose sloping downward.
- When connecting an extension drain hose, insulate the connecting part of extension drain hose with a shield pipe, do not let the drain hose droop or kink.

Mounting Plate Dimensions

Different models have different mounting plates. In order to ensure that you have ample room to mount the indoor unit, the table to the right shows mounting plate dimensions:

- Width of mounting plate
- Height of mounting plate
- Width of indoor unit relative to plate
- Height of indoor unit relative to plate
- Recommended position of wall hole (both to the left and right of mounting plate)
- Relative distances between screw holes

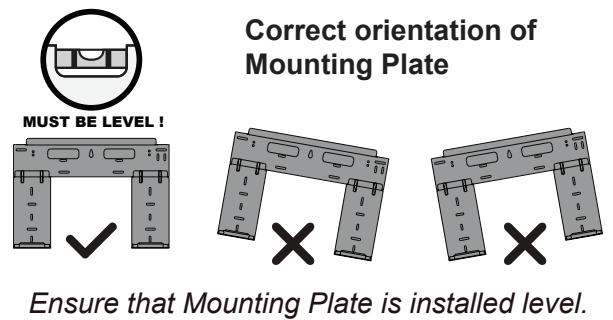

HINRP20MB

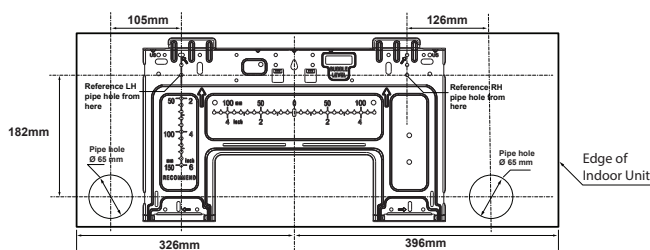

HINRP26MB & HINRP35MB

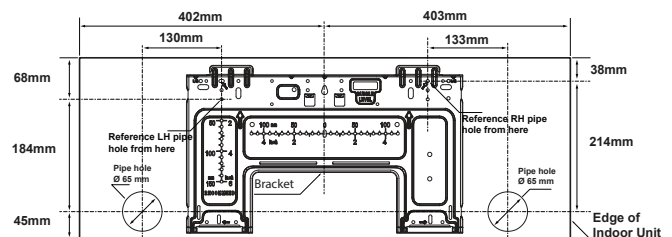

HINRP50MB & HINRP60MB

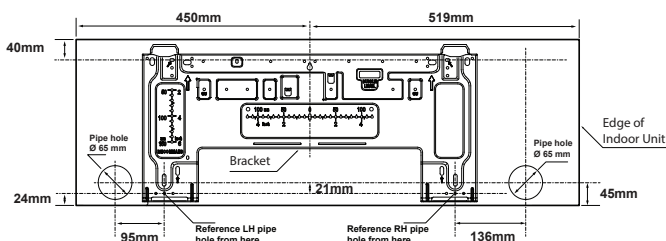

HINRP70MB & HINRP80MB

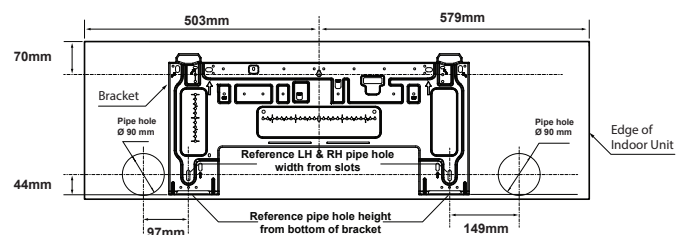

When the gas side connective pipe is Ø16mm or more, the wall hole should be 90mm.

PIPING AND WRAPPING

Bundle the refrigerant pipe, connecting cable, and condensate drain hose with tape securely.

- Condensate is drained away from the indoor unit via a condensate tray. **DO NOT** put any foreign objects in the tray as it may block the drain and cause a water leak.



Connect the indoor unit first, then install the outdoor unit.

- Ensure the bundled pipework is retained in the rear of the indoor unit.
- Ensure that the condensate drain falls correctly.
- Insulate the refrigerant pipes individually.
- Ensure that the condensate drain hose is at the bottom of the bundle. If located at the top of the bundle it will cause the condensate tray to overflow inside the unit.
- Ensure that the power wiring is routed separately to all other wiring.
- Run the condensate drain hose sloped downward to ensure the condensate flows away effectively.

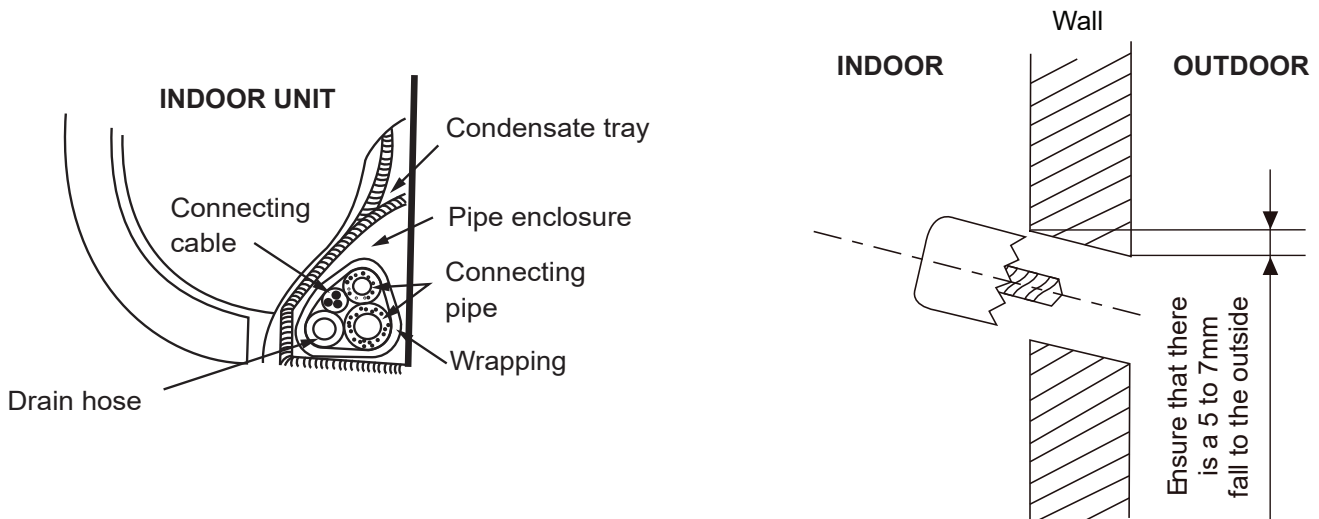







INDOOR UNIT INSTALLATION

1. Pass the piping through the hole in the wall.
2. Put the upper slot at the back of the indoor unit on the upper hook of the installation plate, move the indoor unit from side to side to see that it is securely hooked.
3. Piping can be manipulated more easily by propping the indoor unit out from the wall.
4. Push the lower part of the indoor unit onto the wall, then move the indoor unit from side to side, up and down to check it is securely fastened on the installation plate.

INDOOR UNIT DUCTED ACCESSORIES

The Air Conditioning system comes with the following accessories. Use all of the installation parts and accessories to install the air conditioner. Improper installation may result in water leakage, electrical shock and fire, or cause the equipment to fail.

	Name	Shape	Quantity
Tubing & Fittings	Soundproof/ Insulation Sheath		2
	Seal Sponge		1
Outlet Pipe Sheath	Outlet Pipe Sheath		1
Outlet Pipe Clasp	Outlet Pipe Clasp		2
Wired Controller	Wired Controller		1
Other	Display Panel (for testing purposes)		1 (some models)

Indoor Unit Parts - DINSD26MB & DINSD35MB

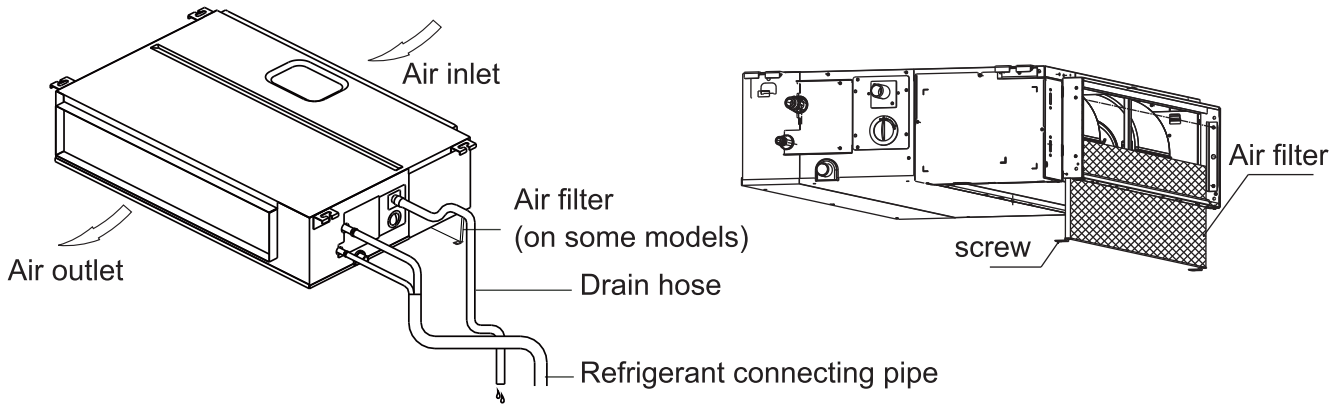

Indoor Unit Parts - DINSD50MB & DINSD70MB

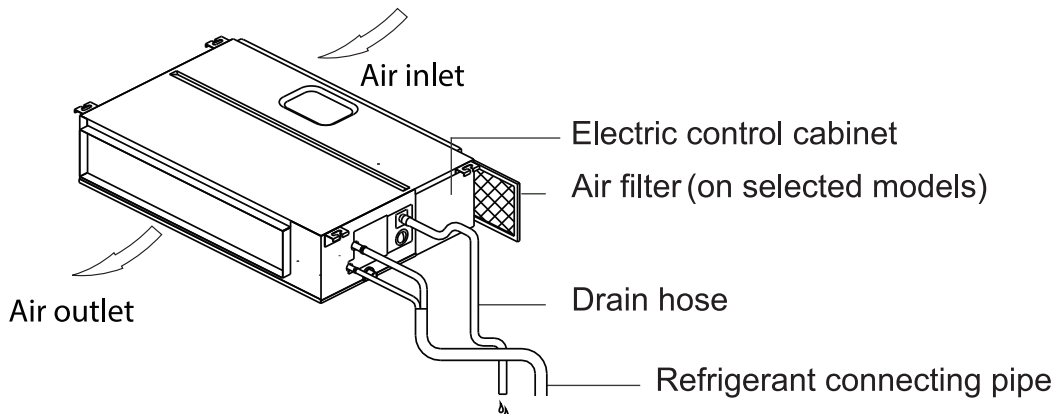

SAFETY PRECAUTIONS

- Securely install the indoor unit on a structure that can sustain its weight. If the structure is too weak, the unit may fall causing personal injury, unit and property damage, or even death
- **DO NOT** install the indoor unit in a bathroom or laundry room as excessive moisture can short the unit and corrode the wiring.



- Install the indoor and outdoor units, cables and wires at least 1 m from televisions or radios to prevent static or image distortion. Depending on the appliances, a 1 m distance may not be sufficient.
- If the indoor unit is installed on a metal part of the building, it must be grounded.

DUCTED INDOOR UNIT INSTALLATION

Installation Position



Panel installation should be performed after piping and wiring have been completed.

Step 1. Select installation location

Before installing the indoor unit, you must choose an appropriate location. The following are standards that will help you choose an appropriate location for the unit.

Proper installation locations meet the following standards:

- Enough room exists for installation and maintenance.
- Enough room exists for the connecting the pipe and drainpipe.
- The ceiling is horizontal and its structure can sustain the weight of the indoor unit.
- The air inlet and outlet are not blocked.
- The airflow can fill the entire room.
- It is a fixed installation
- There is no direct radiation from heaters.
- Models with cooling capacity of 2.6 kW to 5 kW only applies to one room

SERVICE ACCESS

Service space - all models

Ensure enough space required for installation and maintenance.

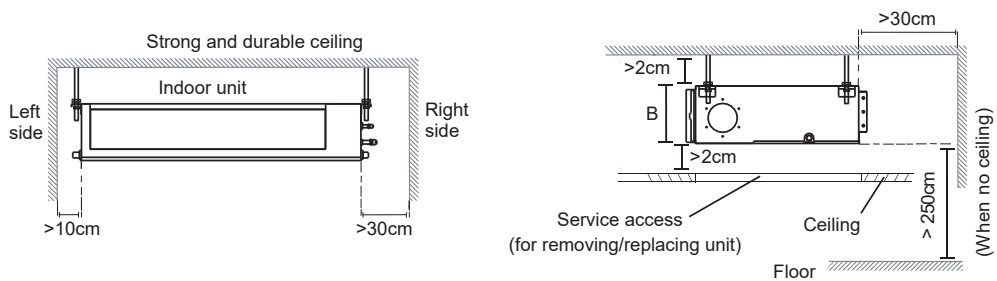

Maintenance space

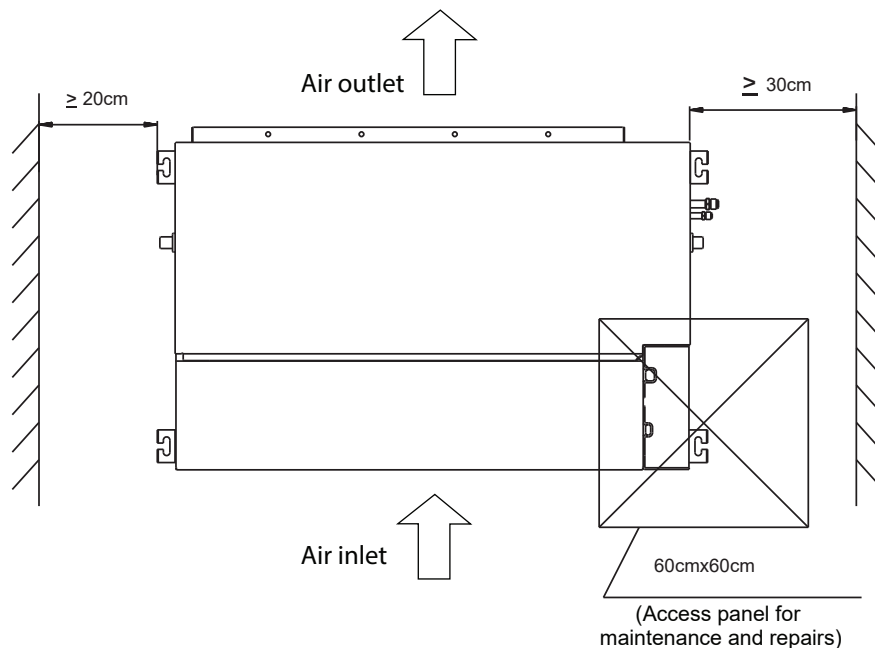



DO NOT install unit in the locations as detailed below.

DO NOT install unit in the following locations:

- Under a floor or beneath a deck, to be installed in a roof space only.
- Areas with oil drilling or fracking
- Coastal areas with high salt content in the air
- Near geothermal activity and corrosive gas
- Areas with caustic gases in the air, such as hot springs
- Areas that experience power fluctuations, such as factories
- Enclosed spaces, such as cabinets
- Kitchens that use natural gas
- Areas with strong electromagnetic waves
- Areas that store flammable materials or gas
- Rooms with high humidity, such as bathrooms or laundry rooms.

Step 2. Hang indoor unit

1. Please refer to the following diagrams to locate the four positioning screw bolt holes on the ceiling. Be sure to mark the places where you will drill ceiling hook holes.

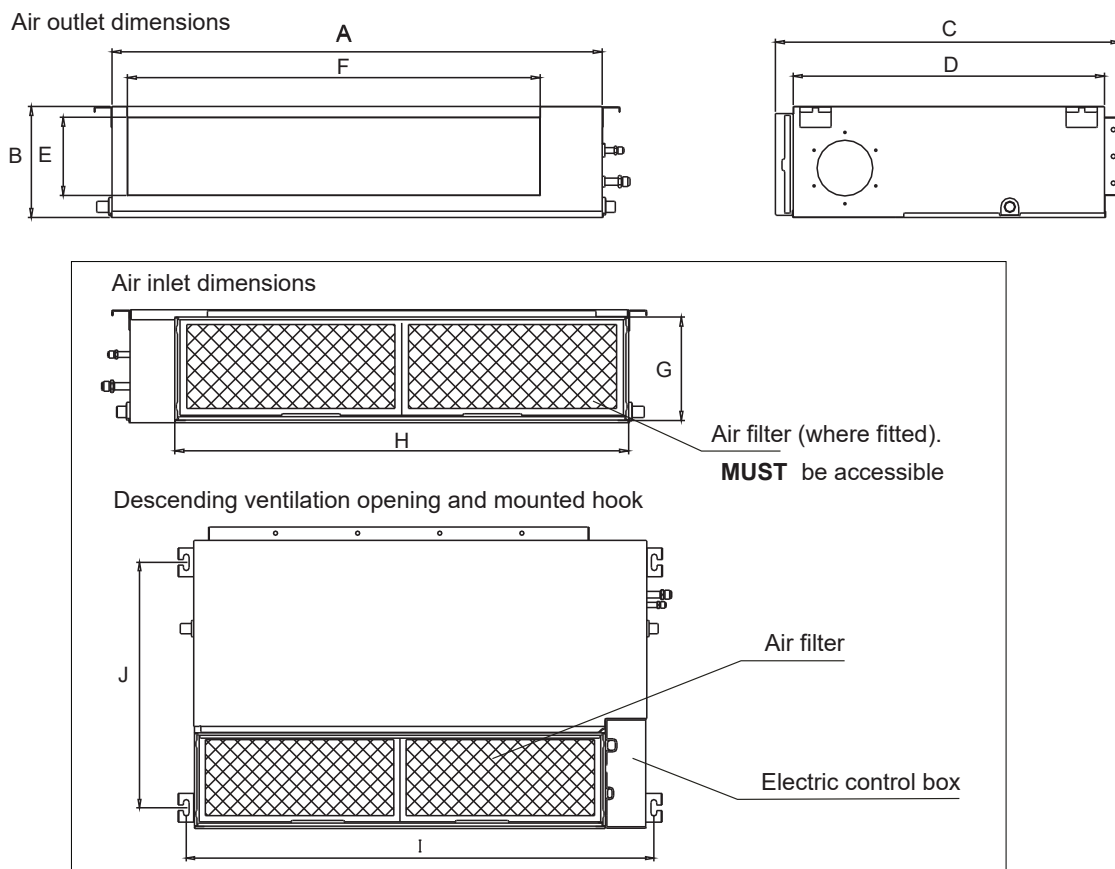

Model (kW)	Outline Dimension (mm)				Air Outlet Opening Size (mm)		Air Return Opening Size (mm)		Size of Mounted Lug (mm)	
	A	B	C	D	E	F	G	H	I	J
DINSD26MB	700	200	506	450	152	537	186	599	741	360
DINSD35MB										
DINSD50MB	880	210	674	600	136	706	190	782	920	360
DINSD70MB	1100	249	774	700	175	926	228	1001	1140	598

Wood

The mounting holes for upper foam are used for auxiliary positioning bolts (if the foam is damaged or damaged, the spacing between the actual lifting lugs shall be the standard).

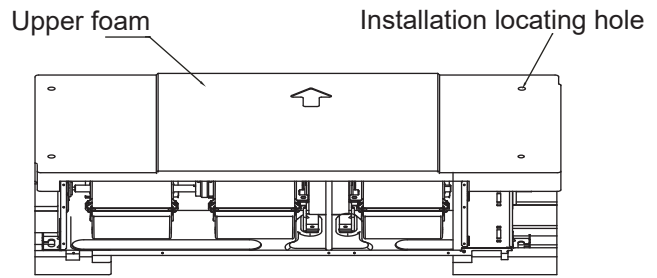

Put the mounting timber transversely over the roof beams, and then install the hanging bolts.

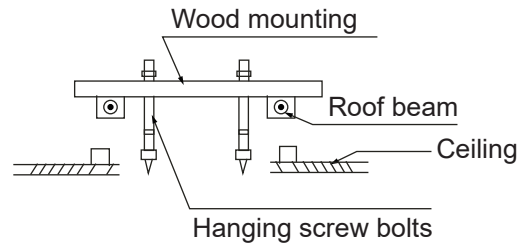

New concrete bricks

Inlaying or embedding the screw bolts.

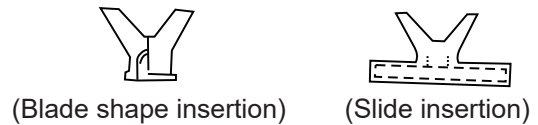

Original concrete bricks

Use an embedding screw bolt, crook and thread harness.

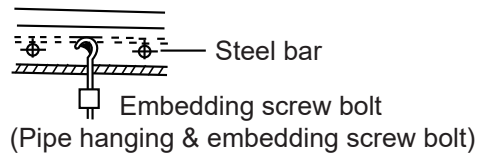

Steel roof beam structure

Install and directly mount the supporting steel angle.

CAUTION The unit body must be completely aligned with the hole. Ensure that the unit and the hole are the same size before moving on.

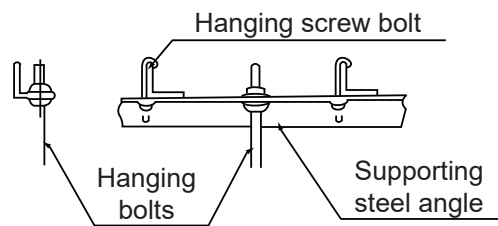

- NOTE**
- Do not place the connecting duct weight on the indoor unit.
 - Use compliant R Rated duct for the area of installation.
 - When connecting duct, install to allow for removal and maintenance.
 - Change the fan motor static pressure corresponding to external duct static pressure.

NOTE All the illustrations in this manual are for demonstration purposes only. The air conditioner you have purchased may be slightly different in design, though similar in shape.

MOUNTING INDOOR UNIT



The unit body must be completely aligned with the hole. Ensure that the unit and the hole are the same size before moving on.

2. Install and fit pipes and wires after you have finished installing the main body. When choosing where to start, determine the direction of the pipes to be drawn out. Especially in cases where there is a ceiling involved, align the refrigerant pipes, drain pipes, and indoor and outdoor lines with their connection points before mounting the unit.
3. Install hanging screw bolts.
 - Cut off the roof beam.
 - Strengthen the point at which the cut was made. Consolidate the roof beam.
4. After you select an installation location, align the refrigerant pipes, drain pipes, as well as indoor and outdoor wires with their connection points before mounting the unit.
5. Drill 4 holes 10cm deep at the ceiling hook positions in the internal ceiling. Be sure to hold the drill at a 90° angle to the ceiling.
6. Secure the bolt using the washers and nuts provided.
7. Install the four suspension bolts.
8. Mount the indoor unit with at least two people to lift and secure it. Insert suspension bolts into the unit's hanging holes. Fasten them using the washers and nuts provided (Figure 1).

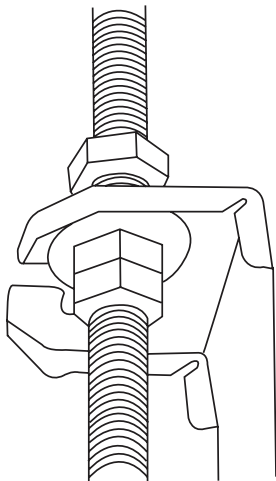

Figure 1.

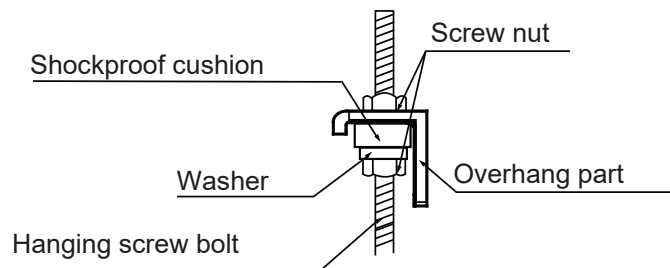

Figure 2.

9. Mount the indoor unit onto the hanging screw bolts with a block. Position the indoor unit flat using a level indicator to prevent leaks (Figure 2).



Confirm the minimum drain tilt is 1/100 or more.

Step 3. Duct and accessories installation

1. Install the filter (optional) according to the size of the air inlet.
2. Install the canvas tie-in between the body and the duct.
3. The air inlet and air outlet duct should be far enough apart enough to a avoid air passage short-circuit.
4. Connect the duct according to the following diagram. See Figure 3 below.

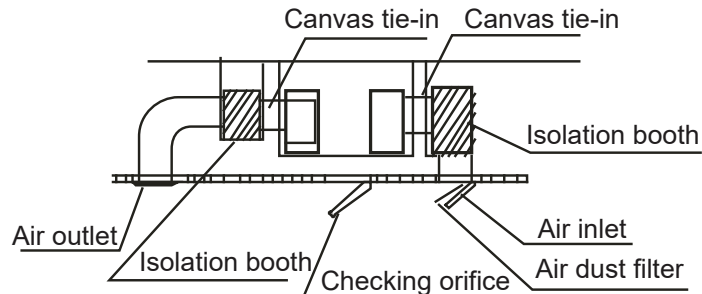

Figure 3.

5. Refer to the following static pressure guidelines when installing the indoor unit.

Models	Static Pressure
DINSD26MB	0~60
DINSD35MB	0~60
DINSD50MB	0~100
DINSD70MB	0~160

Change the fan motor static pressure according to external duct static pressure.



Do not place the connecting duct weight on the indoor unit.

When connecting the duct, use an non-flammable canvas tie-in to prevent vibrating.

Insulation foam must be wrapped outside the duct to avoid condensate. An internal duct under-layer can be added to reduce noise, if the end-user requires.

How to adjust the air inlet direction (from rear side to under-side).

<p>1. Take off the ventilation panel and flange.</p>	<p>Bend the rear ventilation panel 90 degrees along the dotted line into a descending ventilation panel (some models).</p>

2. Change the mounting positions of the ventilation panel and air return flange.

3. When installing the filter mesh, fit it into the flange as illustrated in the following figure.

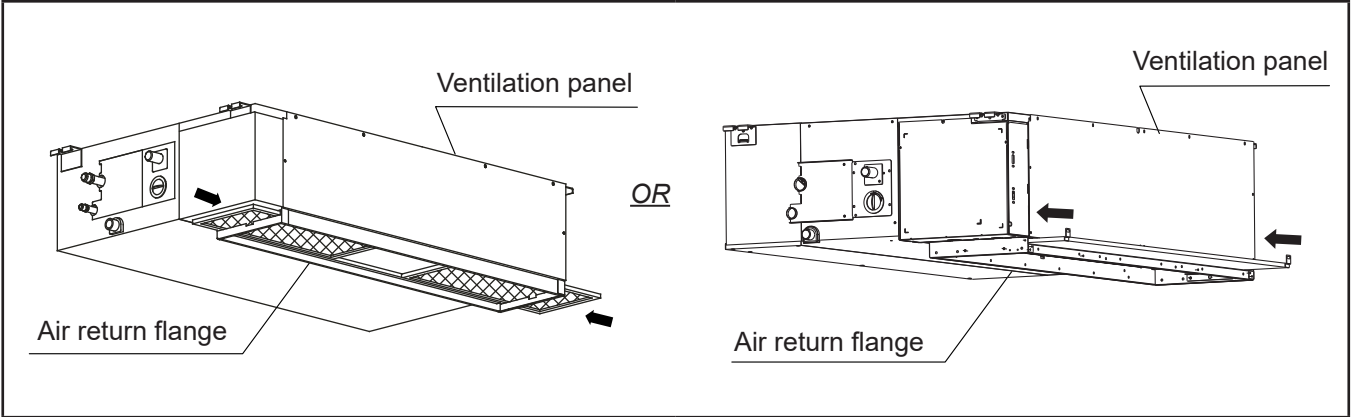

All the illustrations in this manual are for explanation purposes only. They may be slightly different from the air conditioner you purchased. The actual unit shall prevail.

Fresh air duct installation (where fitted)

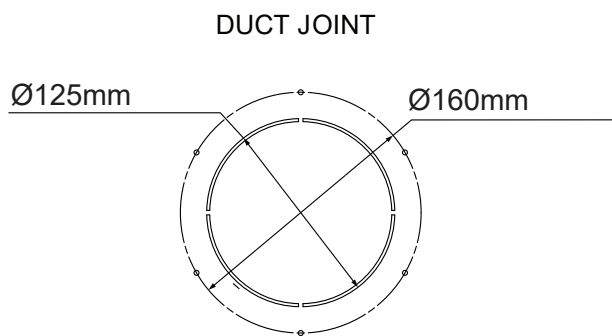
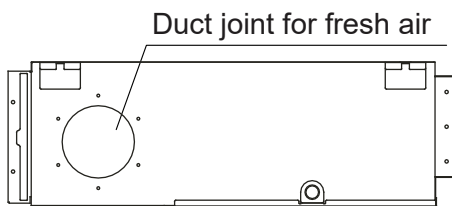

Motor and drain pump maintenance

(Take rear ventilated as example)

Motor Access:

- Take off the ventilated panel.
- Take off the blower housing.
- Take off the motor.

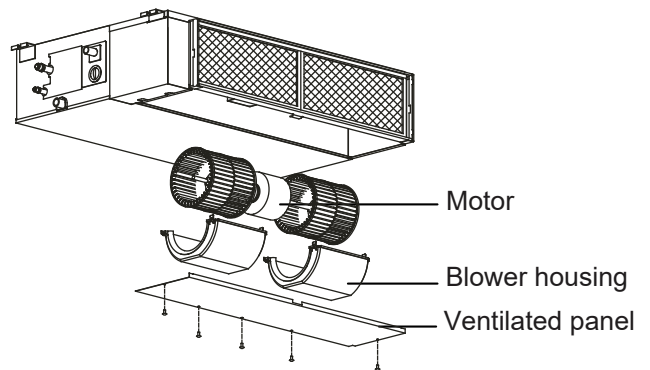

Pump Access:

- Remove four screws from the drain pump.
- Unplug the pump power supply and water level switch cable.
- Take pump out of unit.

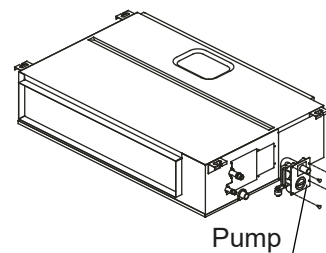

DRAINPIPE INSTALLATION

The drainpipe is used to drain water from the unit. Improper installation may cause unit and property damage.



Insulate all piping to prevent condensation, which could lead to water damage.

- If the drainpipe is bent or installed incorrectly, water may leak and cause a malfunction of the water-level switch.
- In HEAT mode, the outdoor unit will discharge water. Ensure that the drain hose is placed in an appropriate area to avoid water damage & slippage due to frozen drain water.
- **DO NOT** pull the drainpipe forcefully as this could cause it to disconnect.



About purchasing pipes:

This installation requires a polyethylene tube (outside diameter = 3.7-3.9cm, inside diameter = 3.2cm), which can be obtained at your local hardware store or from your dealer.

INDOOR DRAINPIPE INSTALLATION

Install the drainpipe as shown in Figure 4.

1. Cover the drainpipe with heat insulation to prevent condensation and leakage.
2. Attach the mouth of the drain hose to the unit's outlet pipe. Sheath the mouth of the hose and clip it firmly with a pipe clasp. See Figure 5.

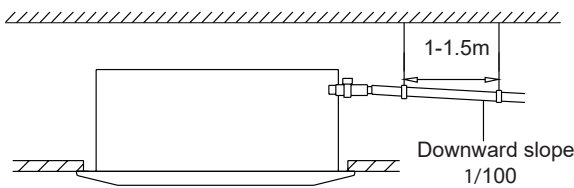

Figure 4.

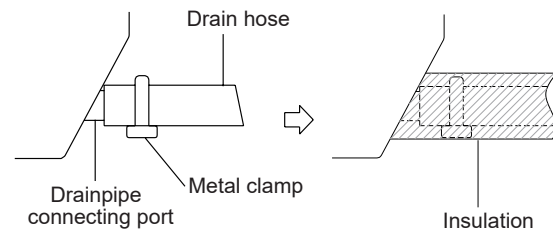

Figure 5.



- When using an extended drainpipe, tighten the indoor connection with an additional protection tube to prevent it from pulling loose.
- The drainpipe should slope downward at a gradient of at least 1/100 to prevent water from flowing back into the air conditioner.
- To prevent the pipe from sagging, space hanging wires every 1-1.5m.
- If the outlet of the drainpipe is higher than the body's pump joint, provide a lift pipe for the exhaust outlet of the indoor unit. The lift pipe must be installed no higher than 75cm from the ceiling board and distance between the unit and the lift pipe must be less than 30cm. Incorrect installation could cause water to flow back into the unit and flood.
- To prevent air bubbles, keep the drain hose level or slightly tilted up (<75mm). See Figure 6.

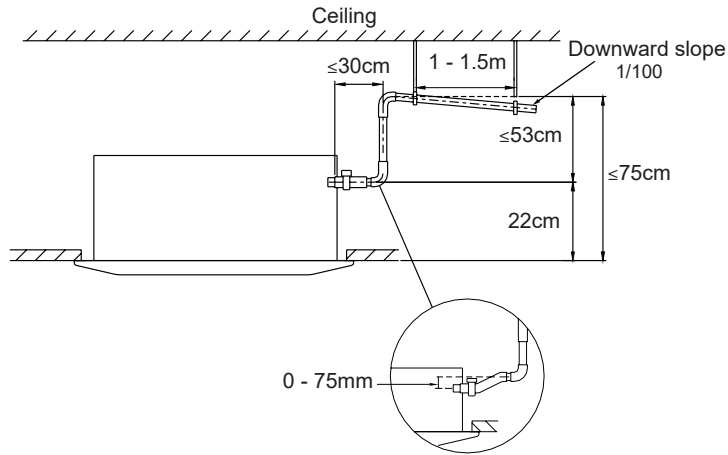

Figure 6.



When connecting multiple drainpipes, install the pipes as shown in Figure below.

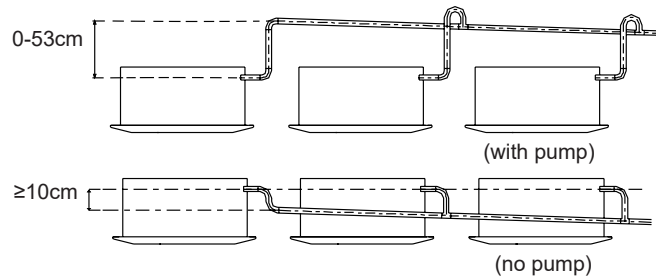
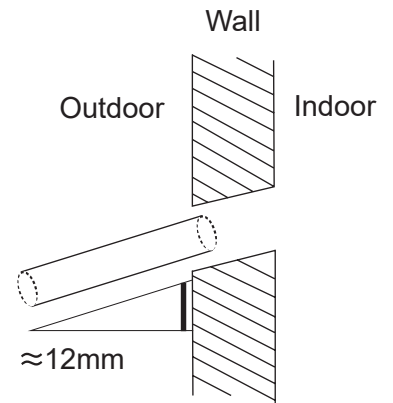

Figure 7.

- Using a core drill, drill a hole in the wall. Make sure that the hole is drilled at a slight downward angle, so that the outdoor end of the hole is lower than the indoor end by about 12 mm. This will ensure proper water drainage. Place the protective wall cuff in the hole. This protects the edges of the hole and will help seal it when you finish the installation process.



When drilling the wall hole, make sure to avoid wires, plumbing, and other sensitive components.



- Pass the drain hose through the wall hole. Make sure the water drains to a safe location where it will not cause water damage or a slipping hazard.



The drain pipe outlet should be at least 5cm above the ground. If it touches the ground, the unit may become blocked and malfunction. If you discharge the water directly into a sewer, make sure that the drain has a U or S pipe to catch odours that might otherwise come back into the house.

DRAINAGE TEST

Check whether the drain pipe is unhindered.

New built house should have this test done before lining the ceiling.

1. Remove the test cap, and pour about 2 litres of water into the condensate pan.

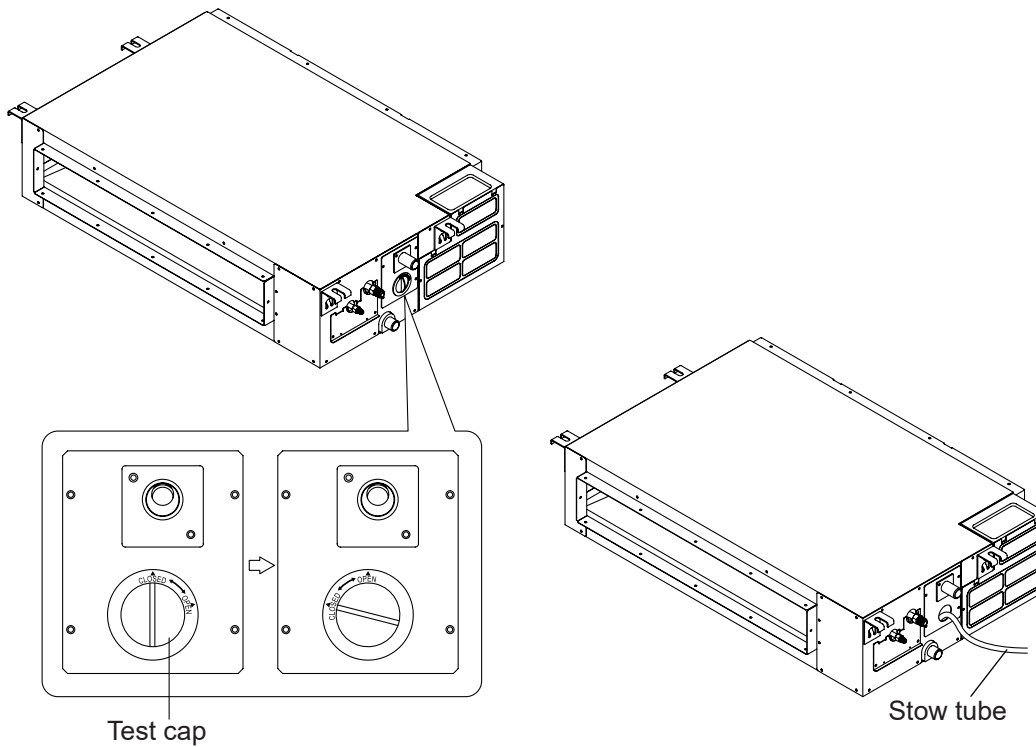

2. Operate the air conditioner in "COOLING" mode. The sound of the drain pump shall be heard. Check whether the water is discharged well (1 minute lag is possible, according to the length of the drain pipe), and check whether the water leaks from the joints.
3. Power off the air conditioner and recover the cap.

SYSTEM SETTINGS

Fan Speed Settings

Setting the fan speed and or external static pressure settings can be done either manually or automatically, using the wired controller supplied with the Indoor unit.

Auto Fan Setting

The system will automatically adjust the fan setting based on the system static pressure.

When the system is OFF, perform the following steps using the wired controller.

- Press the “COPY” button and hold for 3 seconds.
- Press the “+” button to select “AF”.

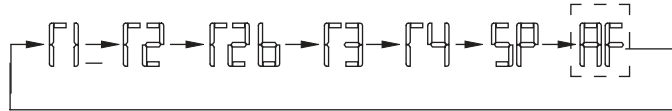

- Press the “CONFIRM” button. The air-conditioner will start the fan operation airflow automatic adjustment.

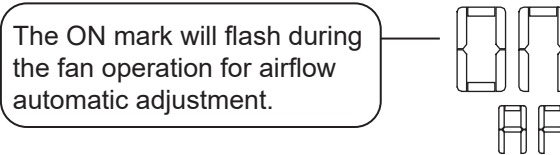

- **DO NOT** adjust the dampers during fan operation for airflow automatic adjustment.

After 3 to 6 minutes, the unit stops automatically when the automatic airflow adjustment has been carried out.

Manual Fan Setting

The system can be set manually based on four static pressure settings.

Each setting has a Low, Medium and High speed range.

External Static Pressure Parameters				
SP No.	DINSD26MB	DINSD35MB	DINSD50MB	DINSD70MB
SP0	Reserved – DO NOT USE			
SP1	0 – 15 Pa	0 – 15 Pa	0 – 25 Pa	0 – 40 Pa
SP2	15 – 30 Pa	15 – 30 Pa	25 – 50 Pa	40 – 80 Pa
SP3	30 – 45 Pa	30 – 45 Pa	50 – 75 Pa	80 – 120 Pa
SP4	45 – 60 Pa	45 – 60 Pa	75 – 100 Pa	120 – 160 Pa

When the system is OFF, perform the following steps using the wired controller.

- Press the “COPY” button and hold for 3 seconds
- Press the “+” or “-” to select the required “SP” option.

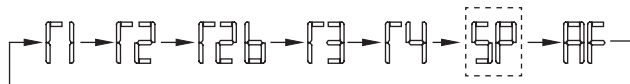

- Press the “CONFIRM” button











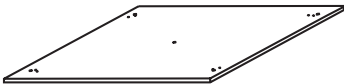

- Press the “CONFIRM” button repeatedly until the desired "SP" number is selected.
- To exit allow to time out.

The External Static Pressure settings is now complete.

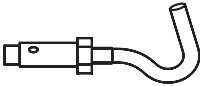
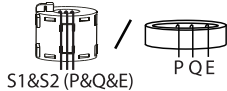
INDOOR CASSETTE INSTALLATION

INDOOR COMPACT CASSETTE ACCESSORIES

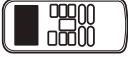
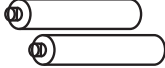
The Air Conditioning system comes with the following accessories. Use all of the installation parts and accessories to install the air conditioner. Improper installation may result in water leakage, electrical shock and fire, or cause the equipment to fail. Items which are not included with the air conditioner must be purchased separately

Name	Shape	Quantity
Manuals		2~4
Installation paper template		1
Soundproof / insulation sheath		1
Anti-shock rubber		1
Outlet pipe clasp		1-2 (depending on models)
Copper nut		2
Ceiling hook		4
Magnetic ring (wrap the electric wires S1 & S2 [P & Q & E] around the magnetic ring twice)	 S1&S2 (P&Q&E) P Q E	1
Suspension bolt		4
Magnetic ring (hitch it on the connective cable between indoor unit and outdoor unit after installation).		Varies by model
Tapping screw		4
Remote controller		1
Battery		2
Connecting pipe		1

INDOOR COMPACT CASSETTE INSTALLATION INSTRUCTIONS

Panel installation must be performed after piping and wiring have been completed.

Step 1. Select installation location

Before installing the indoor unit, you must choose an appropriate location. The indoor unit should be installed in a location that meets the following requirements.

Required installation locations

- The unit is at least 1m from the nearest wall.
- There is enough room for installation and maintenance.
- There is enough room for the connecting pipe and drainpipe.
- The ceiling is horizontal and its structure can sustain the weight of the indoor unit.
- The air inlet and outlet are not impeded.
- The airflow can fill the entire room.
- There is no direct radiation from heaters.

DO NOT install the unit in the following locations

- In areas with oil drilling or fracking
- In coastal areas with high salt content in the air
- In areas with caustic gases in the air, such as near hot springs
- In areas with power fluctuations, such as factories
- In enclosed spaces, such as cabinets
- In kitchens that use natural gas
- In areas with strong electromagnetic waves
- In areas that store flammable materials or gas
- In rooms with high humidity, such as bathrooms or laundry rooms

Recommended clearance between the indoor unit and the ceiling

- The clearance between the mounted indoor unit and the internal ceiling should meet the following specifications (see figure below).

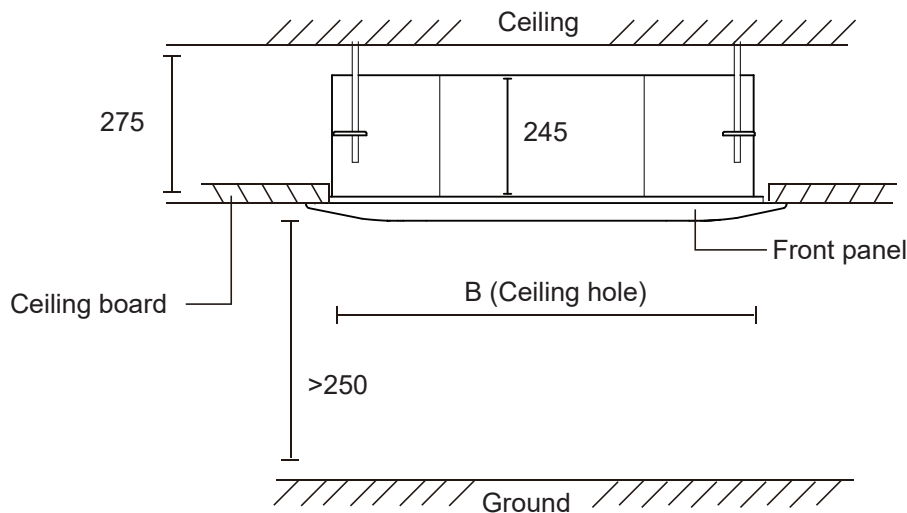

All measurements are in cm unless otherwise specified

Step 2. Hang indoor unit.

1. Use the included paper template to cut a rectangular hole in the ceiling, leaving at least 1m on all sides. The cut hole size will be at a diameter of 4cm larger than the body size. Be sure to mark the areas where ceiling hook holes will be drilled.

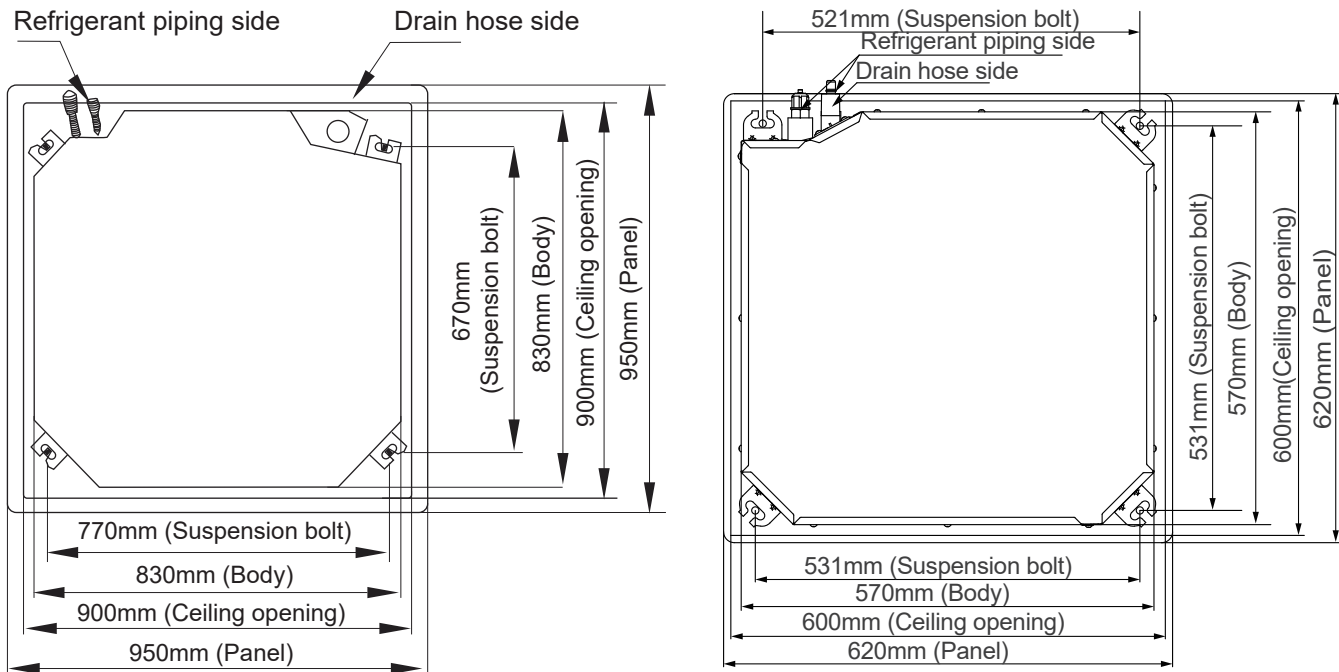

(Model: 7K/9K/12K/18K)

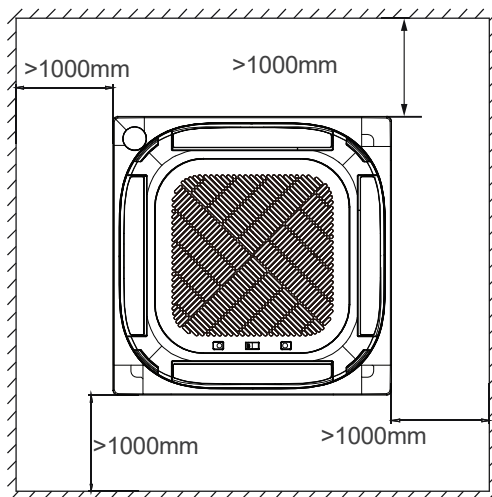

The unit body should align perfectly with the hole. Ensure that the unit and the hole are the same size before continuing.

2. Drill 4 holes 12cm-15.5cm deep at the ceiling hook positions in the internal ceiling. Be sure to hold the drill at a 90° angle to the ceiling.
3. Using a hammer, insert the ceiling hooks into the pre-drilled holes. Secure the bolt using the included washers and nuts.
4. Install the four suspension bolts. (See figure on right.)

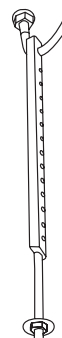

5. Mount the indoor unit. You will need two people to lift and secure it. Insert suspension bolts into the unit's hanging holes. Fasten them using the included washers and nuts

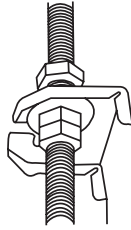

The bottom of the unit should be 10-25mm higher than the ceiling board. Generally, 'L' (indicated in the following figure) should be half the length of the suspension bolt or long enough to prevent the nuts from coming off.

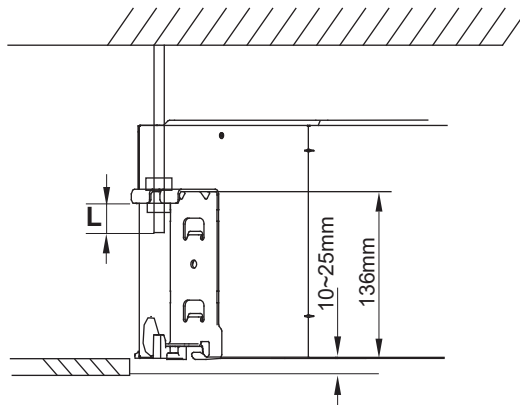

Ensure that the unit is completely level. Improper installation can cause the drain pipe to back up into the unit or water leakage.



Ensure that the indoor unit is level. The unit is equipped with a built-in drain pump and float switch. If the unit is tilted against the direction of condensate flows (the drainpipe side is raised), the float switch may malfunction and cause water to leak. (For some models.)

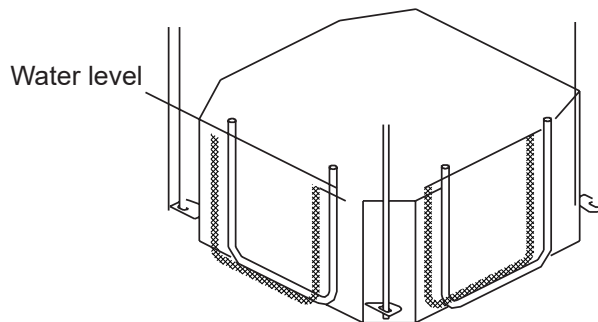

For new home installation

When installing the unit in a new home, the ceiling hooks can be embedded in advance. Make sure that the hooks do not come loose due to concrete shrinkage. After installing the indoor unit, fasten the installation paper template onto the unit with bolts to determine in advance the dimension and position of the opening on the ceiling. Refer to the following instructions for the remainder of the installation.

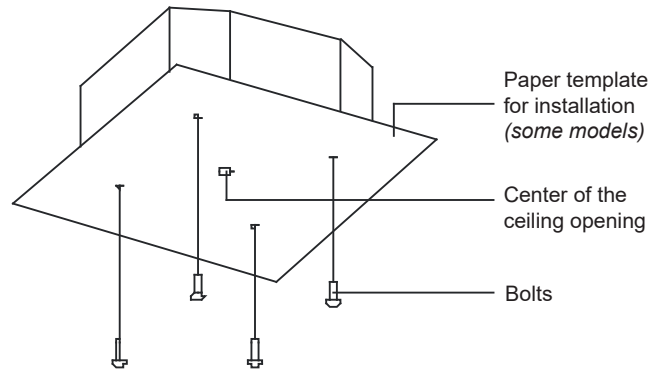

Step 3. Drill wall hole for connective piping

1. Determine the location of the wall hole based on the location of the outdoor unit.
2. Using a 65mm or 90mm (depending on models) core drill, drill a hole in the wall. Make sure that the hole is drilled at a slight downward angle, so that the outdoor end of the hole is lower than the indoor end by about 12mm. This will ensure proper water drainage.
3. Place the protective wall cuff in the hole. This protects the edges of the hole and will help seal it when you finish the installation process.



When drilling the wall hole, make sure to avoid wires, plumbing, and other sensitive components..

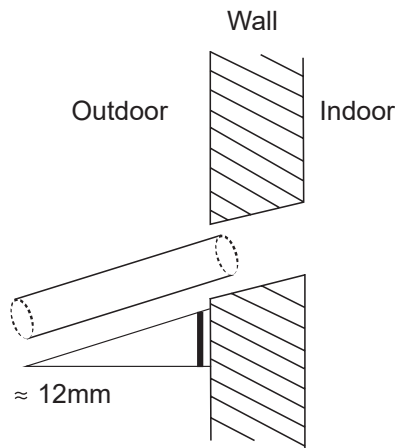

Step 4. Connect drain hose

The drainpipe is used to drain water away from the unit. Improper installation may cause unit and property damage.



- Insulate all piping to prevent condensation, which could lead to water damage.
- If the drainpipe is bent or installed incorrectly, water may leak and cause a water-level switch malfunction.
- In HEAT mode, the outdoor unit will discharge water. Ensure that the drain hose is placed in an appropriate area to avoid water damage and slippage.
- **DO NOT** pull the drainpipe forcefully. This could disconnect it.



Purchasing pipes

Installation requires a polyethylene tube (exterior diameter= 2.5cm or 3.7-3.9cm) (depending on models), which can be obtained at your local hardware store or dealer.

INDOOR DRAINPIPE INSTALLATION

Install the drainpipe as illustrated in the following figures.

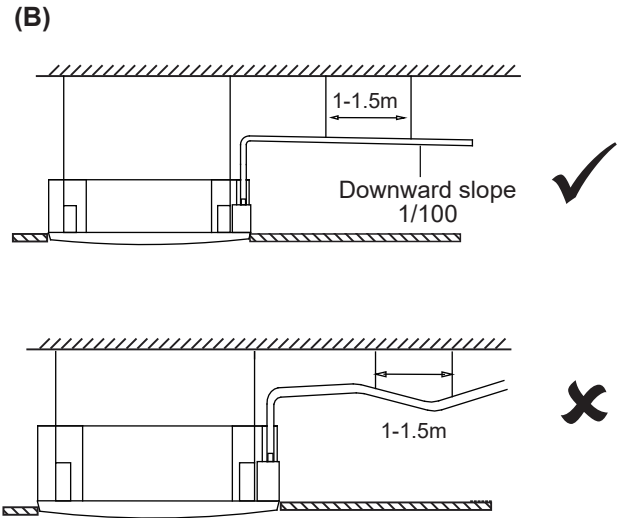
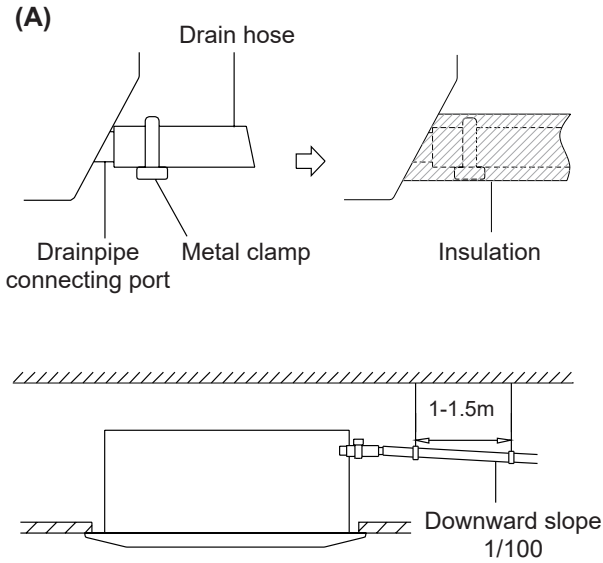

Drainpipe installation

- When using an extended drainpipe, tighten the indoor connection with an additional protection tube to prevent it from pulling loose.
- The drainpipe should slope downward at a gradient of at least 1/100 to prevent water from flowing back into the air conditioner.
- To prevent the pipe from sagging, space hanging wires every 1-1.5m.
- If the outlet of the drainpipe is higher than the body's pump joint, provide a lift pipe for the exhaust outlet of the indoor unit. The lift pipe must be installed no higher than 75cm from the ceiling board and the distance between the unit and the lift pipe must be less than 30cm (depending on models). Incorrect installation could cause water to flow back into the unit and flood.
- To prevent air bubbles, keep the drain hose level or slightly tiled up <75mm (some models).

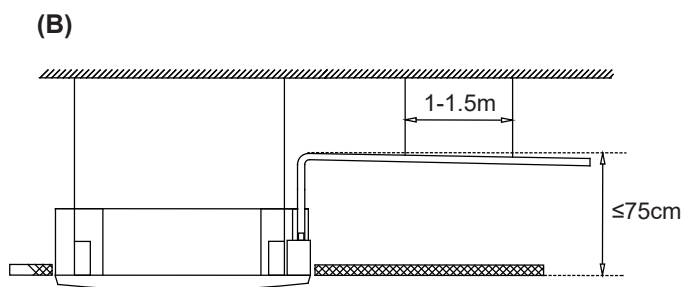
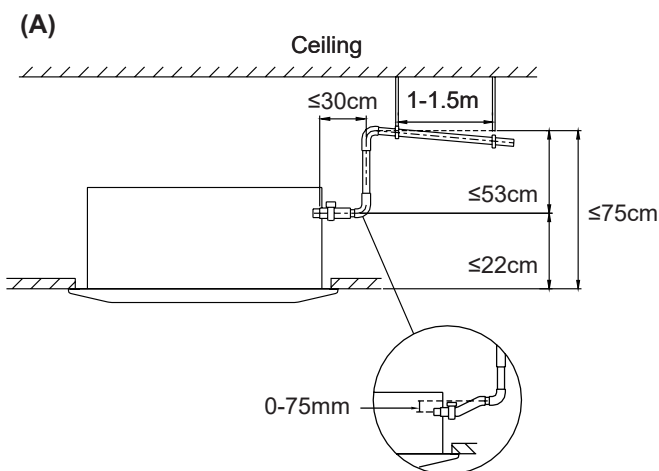

When connecting multiple drainpipes, install the pipes as illustrated in the following figure.

INDOOR CASSETTE INSTALLATION

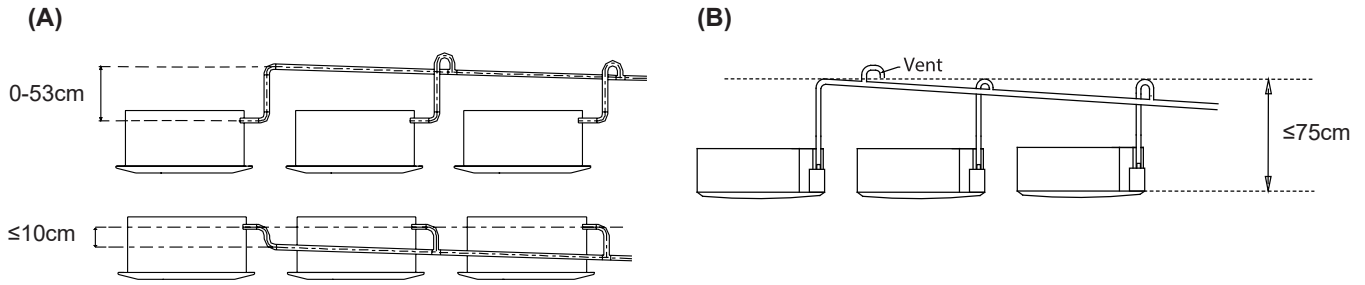

Pass the drain hose through the wall hole. Make sure the water drains to a safe location where it will not cause water damage or a slipping hazard.



The drainpipe outlet should be at least 5cm above the ground. If it touches the ground, the unit may become blocked and malfunction. If you discharge the water directly into a sewer, make sure that the drain has a U or S pipe to catch odours that might otherwise come back into the house.

How to install the conduit installation plate (if supplied).

1. Fix the sheath connector (not supply) on the wire hole of the conduit installation plate
2. Fix the conduit installation plate on the chassis of the unit.

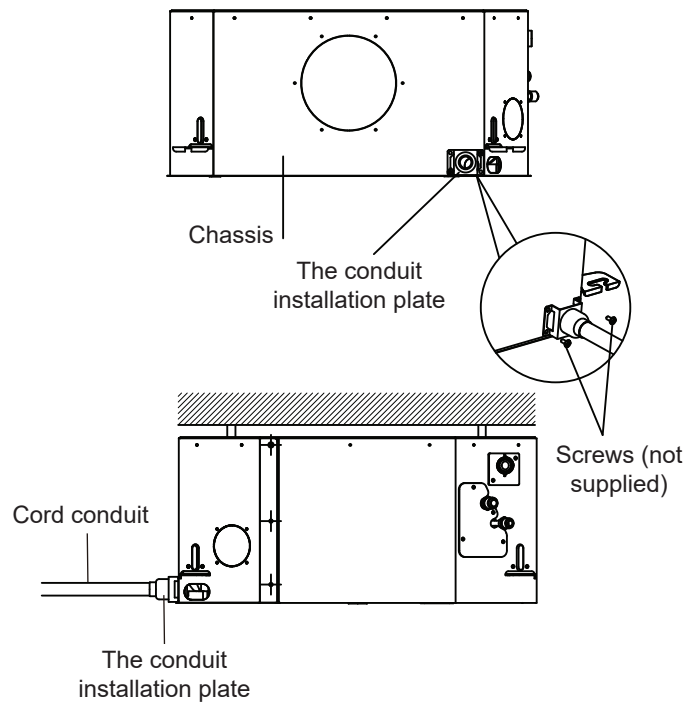

PANEL INSTALLATION FOR COMPACT CASSETTE MODELS

Step 1. Remove the front grille.

1. Push both of the tabs towards the middle simultaneously to unlock the hook on the grille.

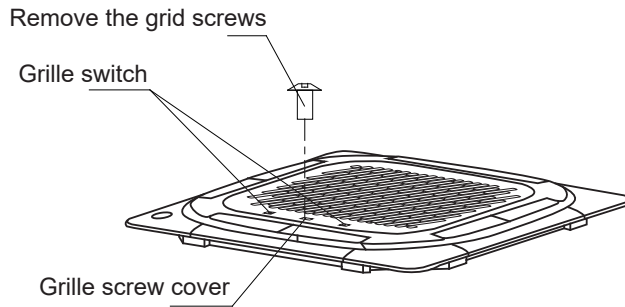

2. Hold the grille at a 45° angle, lift it up slightly and detach it from the main body.

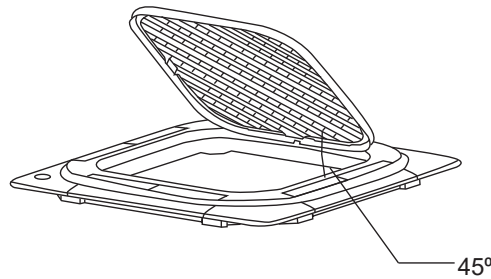

Step 2. The panel hook is pre-hung to the indoor unit flow guide ring, as shown

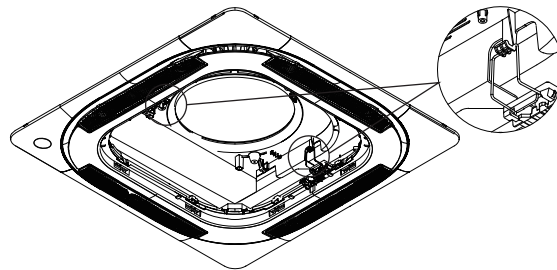

Step 3. Install the fascia with four screws (M5), as shown.

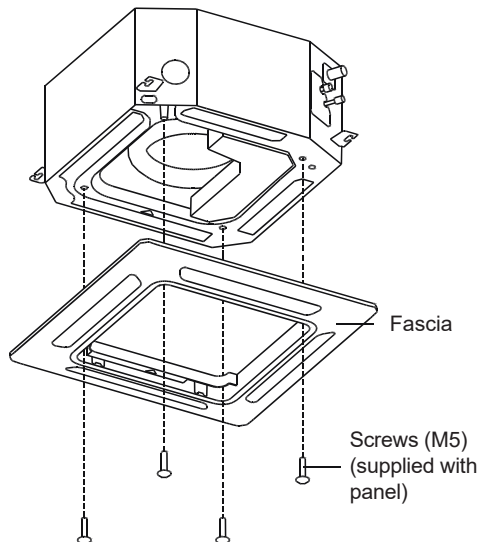

INDOOR CASSETTE INSTALLATION



Tighten the screws until the thickness of the sponge between the main body and the panel reduces to 4-6mm. The edge of the panel should be in contact with the ceiling securely.

Adjust the panel by turning it to the arrowed direction so that the ceiling opening is completely covered.

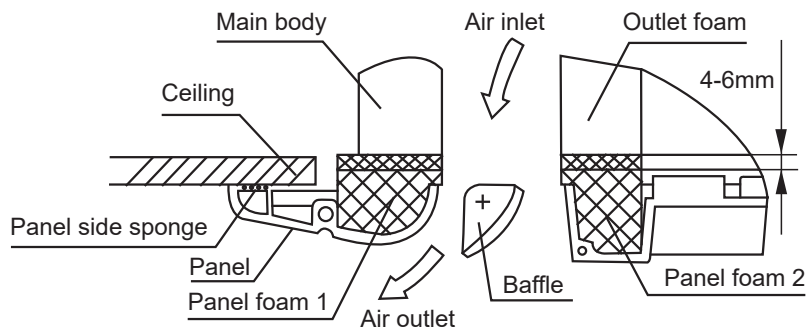
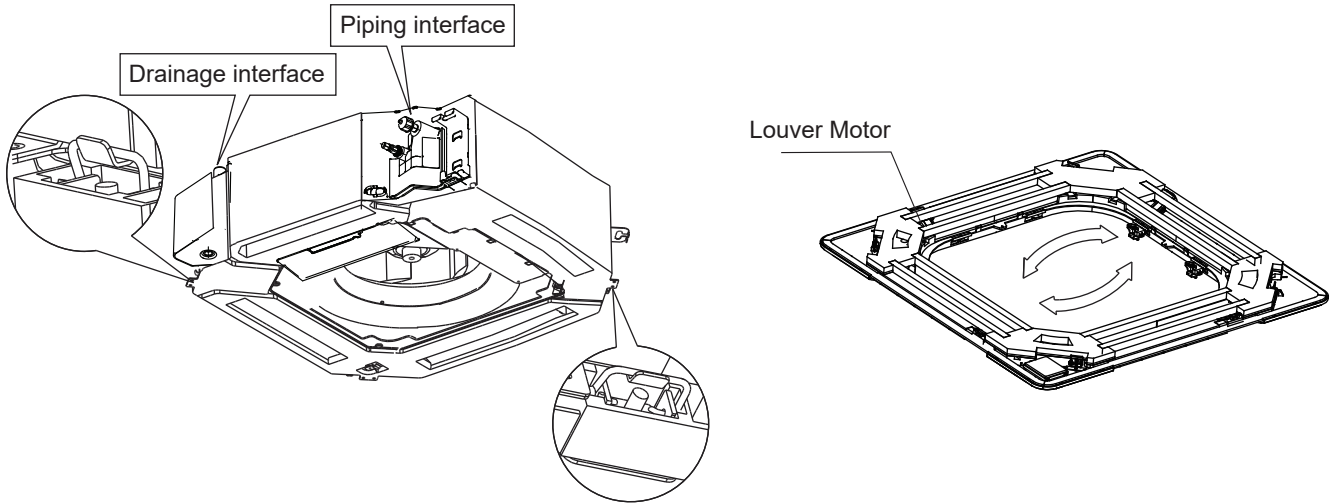

If the height of the indoor unit needs to be adjusted, you can do so through the openings at the panel's four corners. Make sure that the internal wiring and drainpipe are not affected by this adjustment.

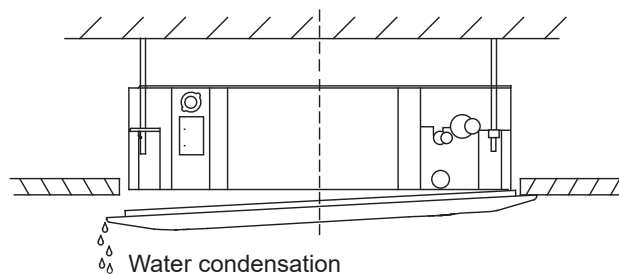

Failure to tighten screws can cause water leakage.

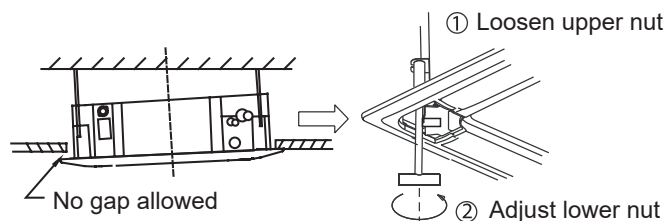



If the unit is not hung correctly and a gap exists, the unit's height must be adjusted to ensure proper function. The unit's height can be adjusted by loosening the upper nut, and adjusting the lower nut.

Hang the intake grille on the panel, and then connect the lead connectors of the louver motor and the control box on the panel to the corresponding connectors of the main body.

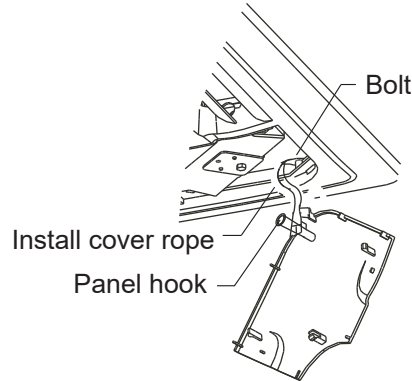

- Reinstall into the style grid.
- Reinstall the installation cover.
- Fix the installation cover plate rope to the pillar of the installation cover plate, and gently press the installation cover plate into the panel.

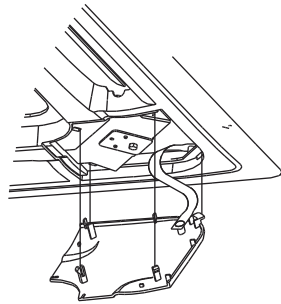

When installing the cover, slide the four slide fasteners into the corresponding slots on the panel.



After installation, the butt plugs of display, swing, water pump and other wire bodies must be placed in the electric control box.

INDOOR FLOOR CONSOLE INSTALLATION

INDOOR FLOOR CONSOLE INSTALLATION INSTRUCTIONS



Panel installation must be performed after piping and wiring have been completed.

Step 1. Select installation location

Before installing the indoor unit, you must choose an appropriate location. The indoor unit should be installed in a location that meets the following requirements.

Required installation locations

- There is enough room for installation and maintenance.
- There is enough room for the connecting pipe and drainpipe.
- The ceiling is horizontal and its structure can sustain the weight of the indoor unit.
- The air inlet and outlet are not impeded.
- The airflow can fill the entire room.
- There is no direct radiation from heaters.

DO NOT install the unit in the following locations

- In areas with oil drilling or fracking
- In coastal areas with high salt content in the air
- In areas with caustic gases in the air, such as near hot springs
- In areas with power fluctuations, such as factories
- In enclosed spaces, such as cabinets
- In kitchens that use natural gas
- In areas with strong electromagnetic waves
- In areas that store flammable materials or gas
- In rooms with high humidity, such as bathrooms or laundry rooms

Recommended clearance between the indoor unit and the ceiling

- The clearance for the mounted indoor unit should meet the following specifications (see figure below).

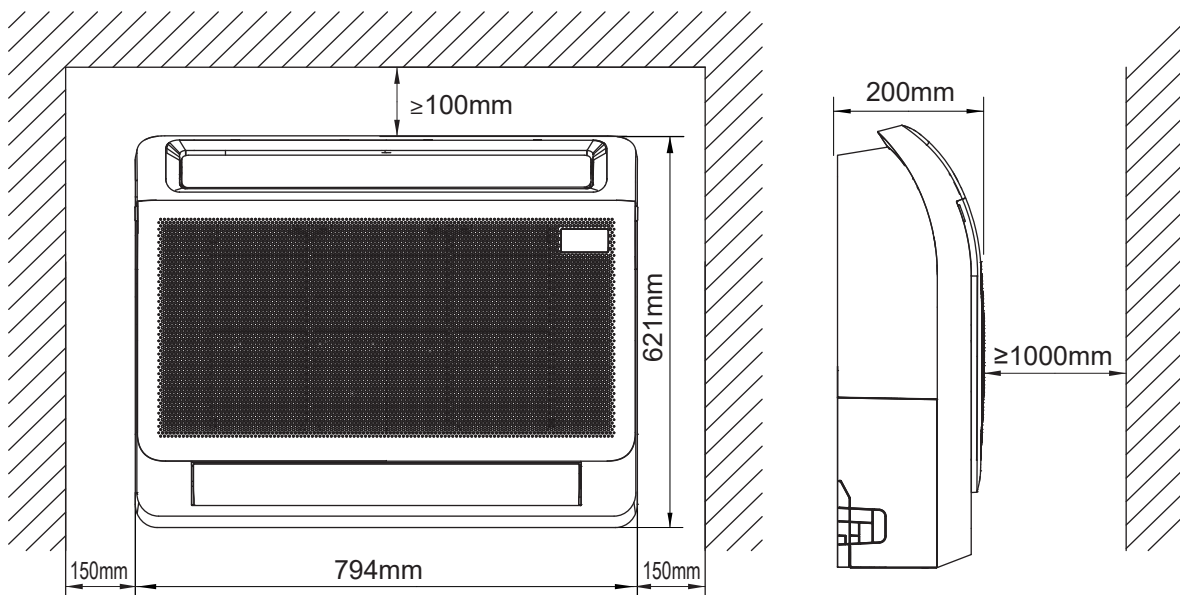

Step 2. Installing the main body of the indoor unit.

- After loosening the screws, remove the mounting plate from the unit.

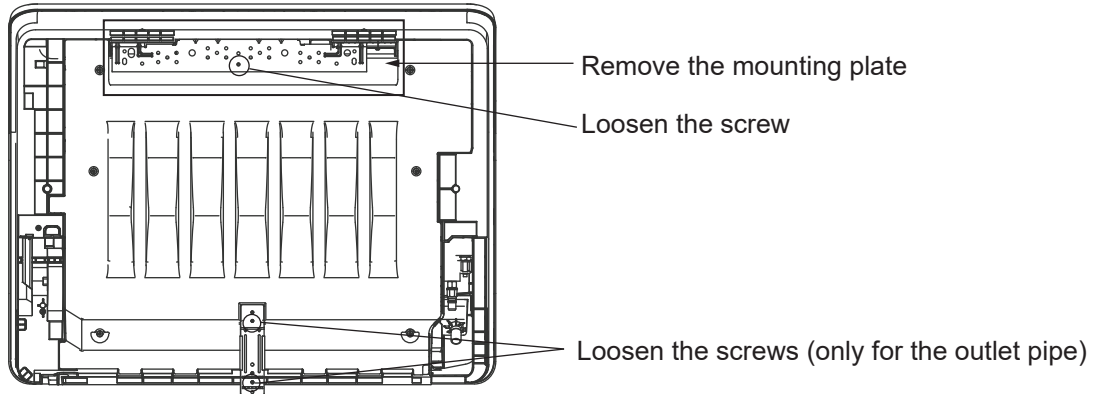

If the pipe comes out on the left, it is necessary to loosen the screws on the bottom mounting plate. If the pipe comes out in other directions, it is not necessary.

- Fix the mounting plate with a tapping screw onto the wall.



It is recommended to fix it on the wall according to the hanging hole indicated by the arrow on the mounting plate. Mounting plate must be installed horizontally.

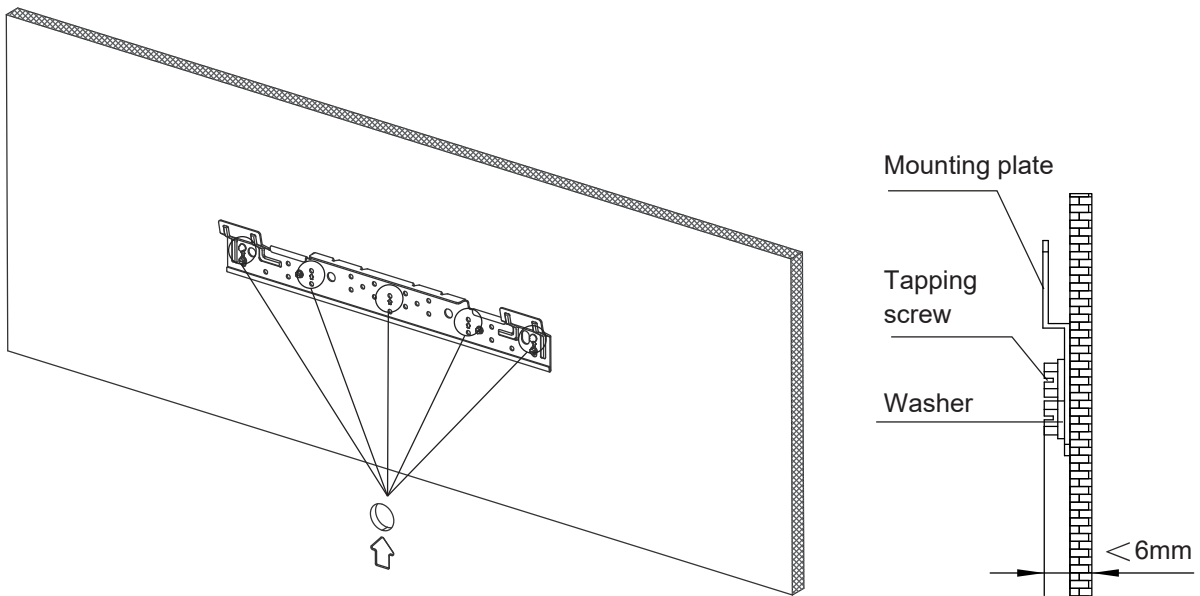

- Hang the indoor unit on the mounting plate. (The bottom of body can touch the floor or remain suspended, but the body must be installed vertically.)



After installation, the unit shall be kept horizontal without tilting.

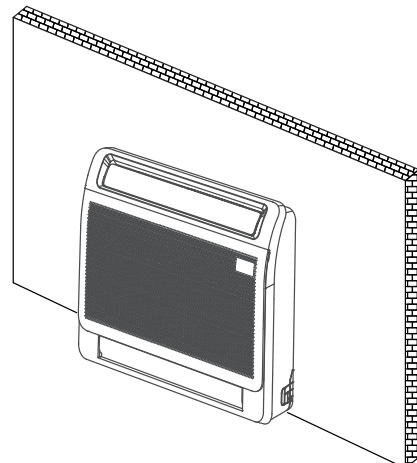

BOTTOM MOUNTING PLATE INSTALLATION

Installation without skirting

The bottom mounting plate is fixed directly to the wall.

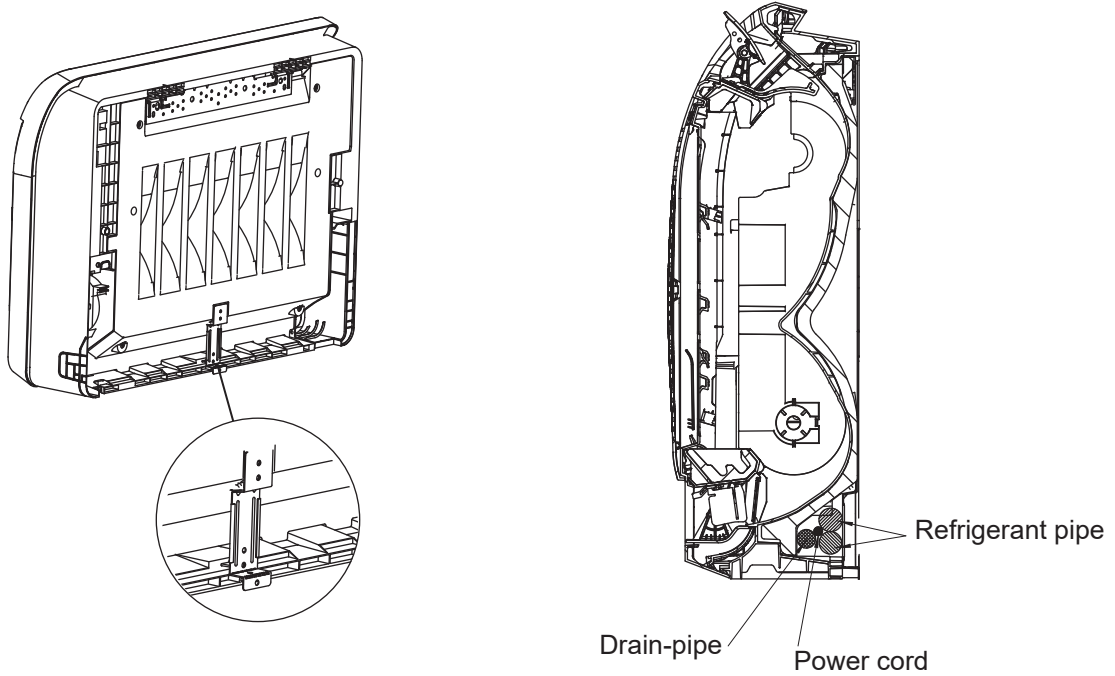

In order to drain smoothly, the position of the drain pipe must refer to the above figure when discharging the right pipe.

Installation with skirting line

Knock the bottom mounting plate straight with a tool and fix it on the skirting line.

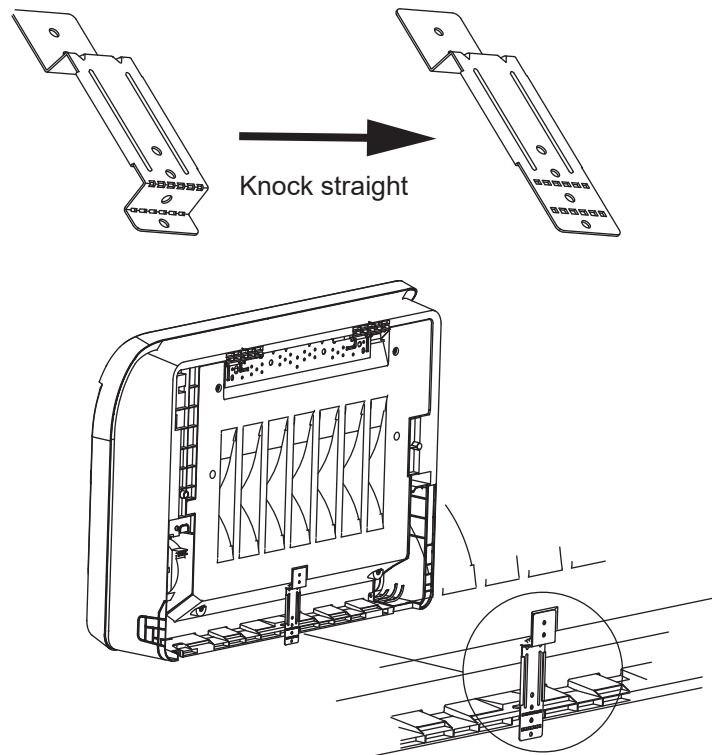

Step 3. Take the indoor unit apart to connect the pipes

1. Open the bottom piping cover plate.

Press and hold the bottom two buckles, and then rotate to open the piping cover plate.

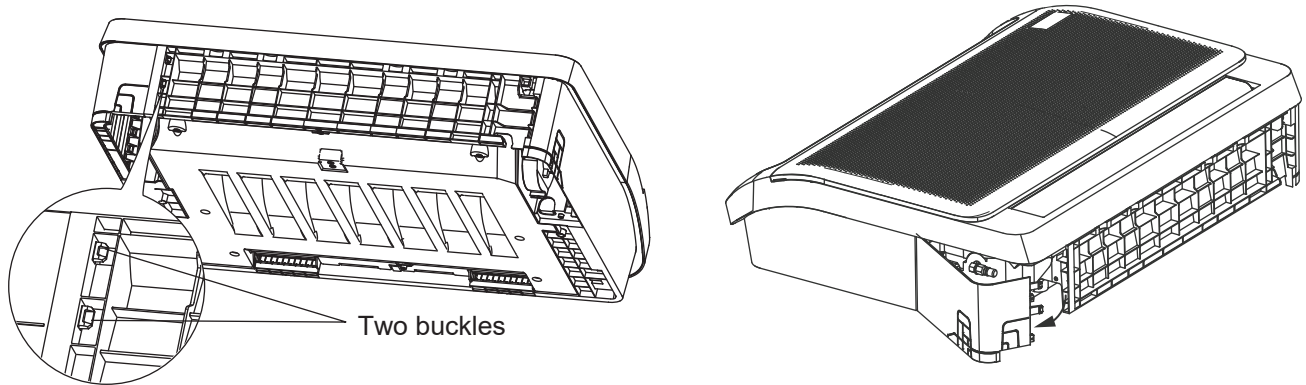

2. Remove the cover plate.

Remove the pipe cover plate and install the internal and external connecting pipes.

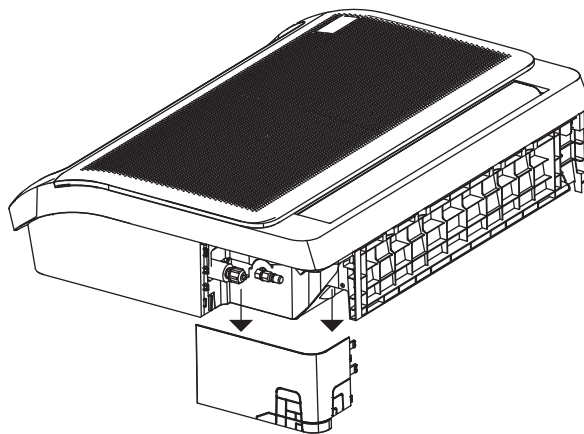

Install small-size piping first, and then large-size piping.



All the figures in this manual are for demonstration purposes only. The air conditioner you have purchased may be slightly different in design, though similar in shape.

Step 4. Network address set (some models)

(Only for the case of optional multi-function board with XYE interface.)

Every air-conditioner in network has only one network address to distinguish each other. Address code of air-conditioner in LAN is set by code switches F1 & ENC3 on the multifunction board of the indoor unit, and the set range is 0-63. (Optional multi-function board.)

Toggle switch set			Network address code
F1	ENC3		
		~	00~15
		~	16~31
		~	32~47
		~	48~63

Step 5. Drill wall hole for connective piping

1. Determine the location of the wall hole based on the location of the outdoor unit.
2. Using a 65mm or 90mm (depending on models) core drill, drill a hole in the wall. Make sure that the hole is drilled at a slight downward angle, so that the outdoor end of the hole is lower than the indoor end by about 12mm. This will ensure proper water drainage.
3. Place the protective wall cuff in the hole. This protects the edges of the hole and will help seal it when you finish the installation process.



When drilling the wall hole, make sure to avoid wires, plumbing, and other sensitive components.

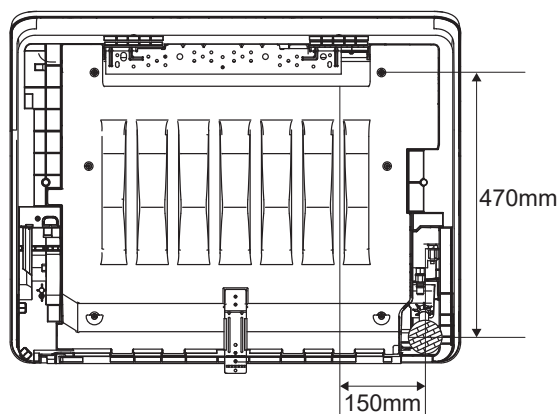
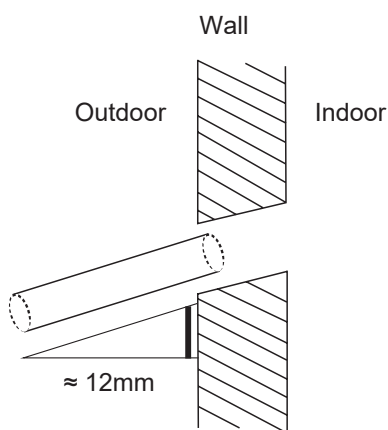

Recommended position and size of back outlet pipe through wall hole (refer to the diagram above).

Step 6. Connect drain hose

The drainpipe is used to drain water away from the unit. Improper installation may cause unit and property damage.



- Insulate all piping to prevent condensation, which could lead to water damage.
- If the drainpipe is bent or installed incorrectly, water may leak and cause a water-level switch malfunction.
- In HEAT mode, the outdoor unit will discharge water. Ensure that the drain hose is placed in an appropriate area to avoid water damage and slippage.
- **DO NOT** pull the drainpipe forcefully. This could disconnect it.



Purchasing pipes

Installation requires a polyethylene tube (exterior diameter= 3.7-3.9cm, interior diameter = 3.2cm), which can be obtained at your local hardware store or dealer.

1. Cover the drainpipe with heat insulation to prevent condensation and leakage.
2. Attach the mouth of the drain hose to the unit's outlet pipe. Sheath the mouth of the hose and clip it firmly with a pipe clasp.

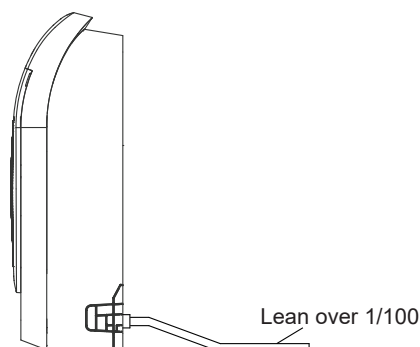
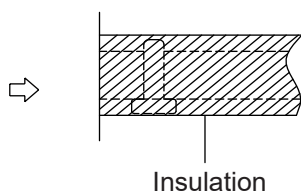
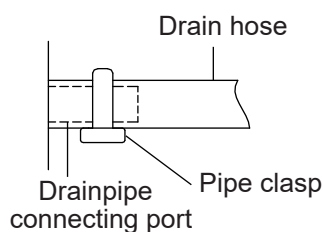



Drainpipe installation

- When using an extended drainpipe, tighten the indoor connection with an additional protection tube to prevent it from pulling loose.
- The drainpipe should slope downward at a gradient of at least 1/100 to prevent water from flowing back into the air conditioner.
- To prevent the pipe from sagging, space hanging wires every 1-1.5m.
- If the outlet of the drainpipe is higher than the body's pump joint, provide a lift pipe for the exhaust outlet of the indoor unit. The lift pipe must be installed no higher than 75cm from the ceiling board and the distance between the unit and the lift pipe must be less than 30cm (depending on models). Incorrect installation could cause water to flow back into the unit and flood.



When connecting multiple drainpipes, install the pipes as illustrated in the following figure.

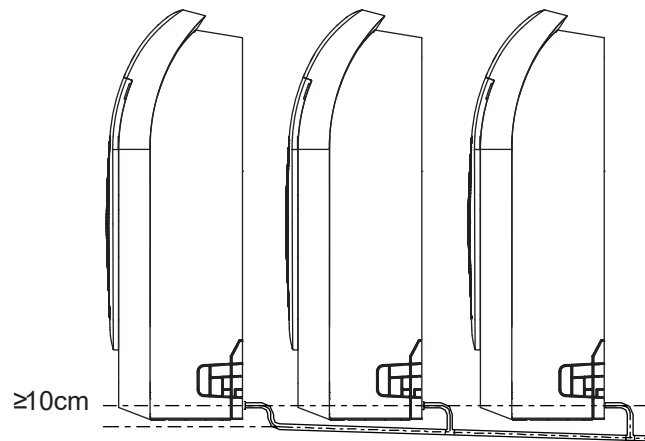

In order to ensure smooth drainage, the height difference between the wall outlet and the hanging plate must be greater than 470mm.

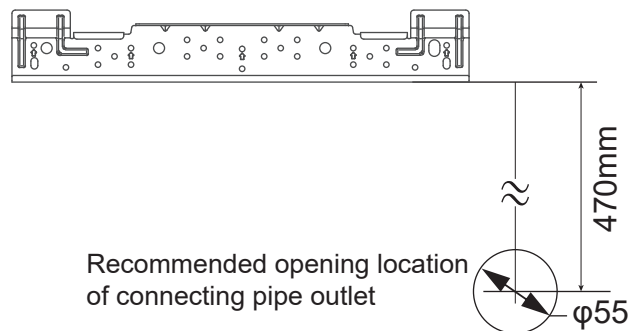

Drainage pipe fixing requirements



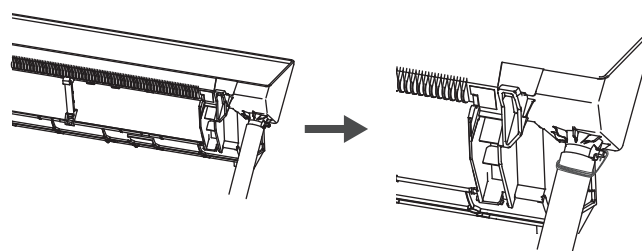

When installing the drainage pipe (not provided), please fix it with a tie or rope.

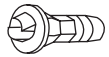

OUTDOOR UNIT INSTALLATION

OUTDOOR UNIT ACCESSORIES

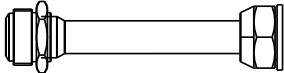
The air conditioning system comes with the following accessories. Use all of the installation parts and accessories to install the air conditioner. Improper installation may result in water leakage, electrical shock and fire, or cause the equipment to fail. The items are not included with the air conditioner must be purchased separately.

Name of Accessories	Qty (pc)	Shape	Name of Accessories	Qty (pc)	Shape		
Manual	2~4		Drain joint	1			
Installation plate (some models)	1		Seal ring (some models)	1			
Plastic expansion sheath (some models)	5-8 (depending on models)		Magnetic ring. Hitch it on the connective cable between indoor unit and outdoor unit after installation (some models).	Varies by model			
Self-Tapping Screw A (some models)							
Pipe Adapter NOTE: Pipe size may differ from appliance to appliance. To meet different pipe size requirements, sometimes the pipe connections need a transfer connector installed on the outdoor unit. Supplied adapters to suit most combinations. If other adapters required, they should be field supplied.			Cord protection rubber ring. If the cord clamp cannot fasten on a small cord, use the cord protection rubber ring (supplied with accessories) to wrap around the cord. Then fix it in place with the cord clamp (some models).	1			
		Model				Adaptor	Qty
	MON3H07B					Ø9.52 - Ø12.7	1
						Ø9.52 - Ø15.9	1
						Ø6.35 - Ø9.52	1
	MON4H09B					Ø12.7 - Ø9.52	1
						Ø12.7 - Ø15.9	1
						Ø9.52 - Ø6.35	1
	MON5H11B					Ø9.52 - Ø12.7	1
						Ø12.7 - Ø9.52	1
						Ø6.35 - Ø9.52	2
	MON5H13B					Ø12.7 - Ø9.52	2
						Ø12.7 - Ø15.9	2
						Ø6.35 - Ø9.52	2
	MON6H18B					Ø12.7 - Ø16.0	2
		Ø9.52 - Ø12.7	1				
		Ø12.7 - Ø9.52	2				

OPTIONAL ACCESSORIES

- There are two types of remote controls: wired and wireless. Select a remote controller based on customer preferences and requirements and install in an appropriate place. Refer to catalogues and technical literature for guidance on selecting a suitable remote controller.

Name	Shape	(mm)	Quantity (pc)
Connecting pipe assembly	Liquid side	Φ6.35	Parts you must purchase separately. Consult the dealer about the proper pipe size of the unit you purchased.
		Φ9.52	
	Gas side	Φ9.52	
		Φ12.7	
		Φ 16	

INSTALLATION SUMMARY

INSTALLATION ORDER

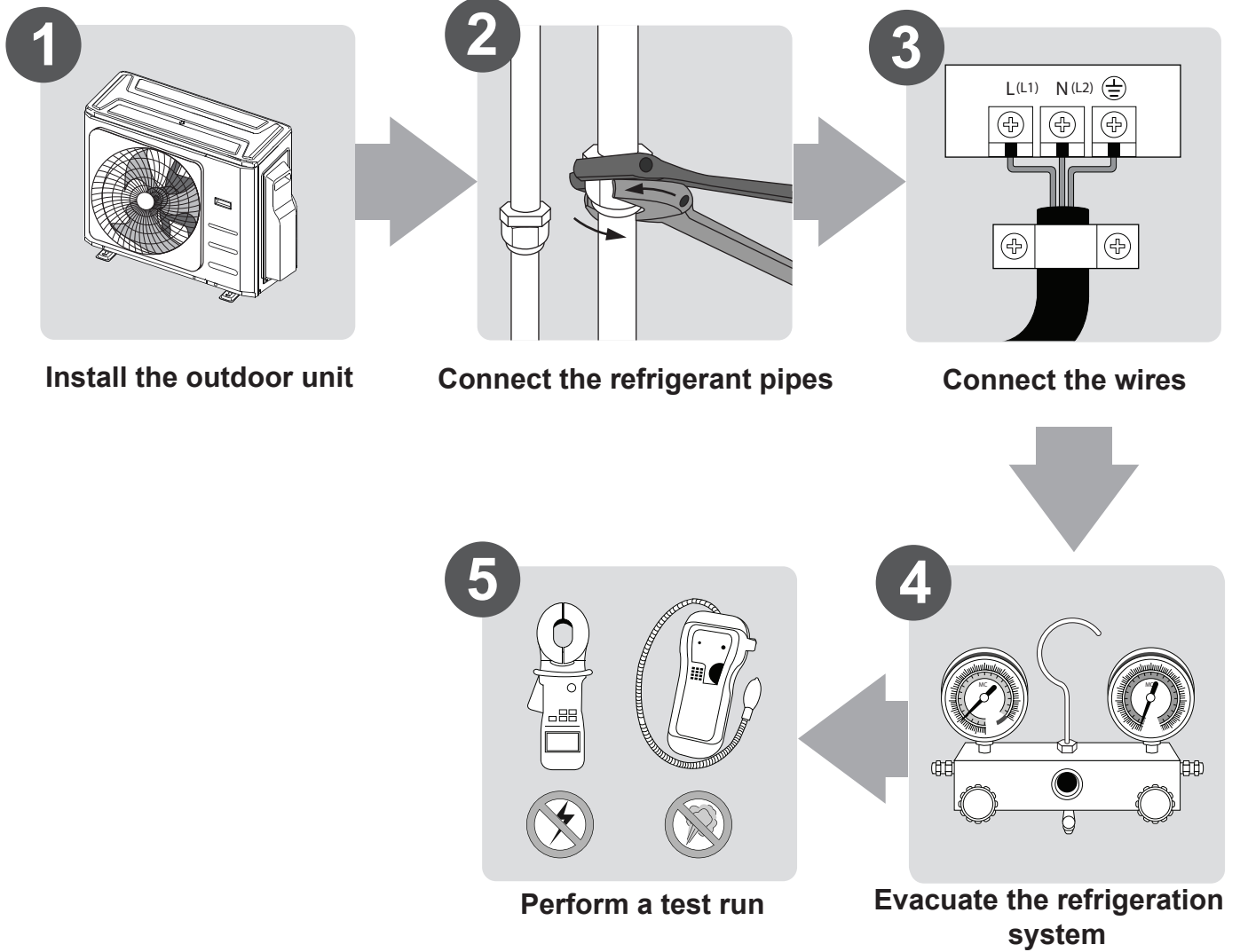

OUTDOOR INSTALLATION

Install the unit by following your Local Regulations and Municipal Building Codes. They may differ slightly between states.

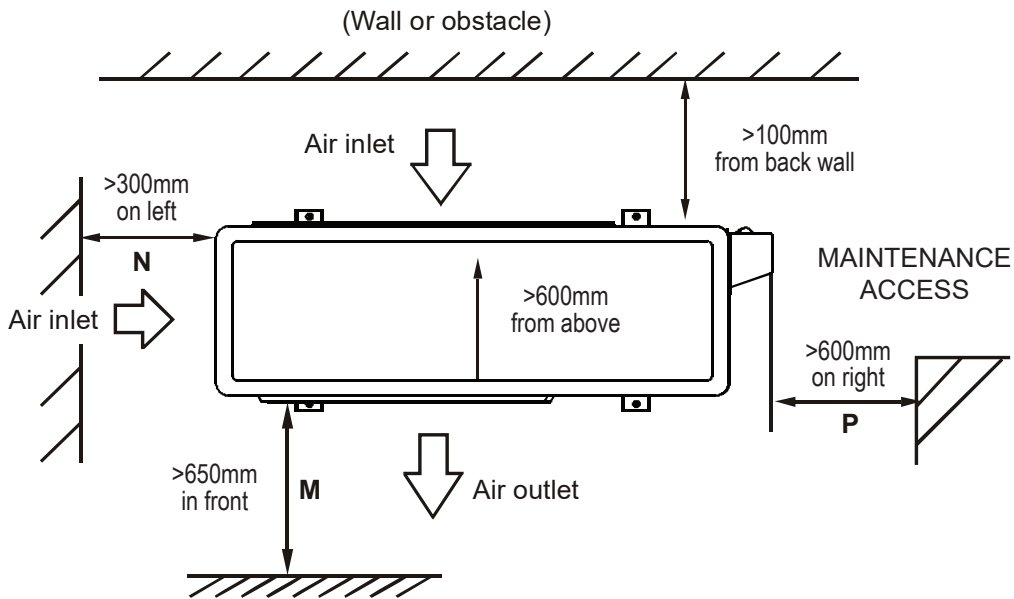

Figure 8.

INSTALLATION INSTRUCTIONS – OUTDOOR UNIT

Step 1. Installation position

The outdoor unit shall be installed in a location that satisfies the following requirements:

- There is sufficient room for installation and maintenance.
- The condenser air path is not blocked or impeded, and cannot be adversely affected by strong prevailing winds.
- It must be in a dry and well ventilated place.
- The supporting structure is flat, horizontal and can withstand the full operating weight of the outdoor unit. The base must be free of vibration.
- Positioned so as to prevent operating noise interference to others.
- Easy installation of interconnecting refrigerant pipes and wiring.
- Arrange condenser air discharge to be free, unimpeded, and not blocked or obstructed.
- Away from any potential fire risks, or flammable materials.
- The refrigerant pipe length or height difference between outdoor and indoor does not exceed the maximum allowable limits.
- For installations prone or exposed to strong prevailing winds or breezes such as coastal areas, please ensure that the unit is sited appropriately, by placing it lengthwise along the wall to reduce any negative impact on the condenser fans. Refer to "Figure 9." on page 49.
- If possible, do not install the unit where it is exposed to direct sunlight, this will negatively impact cooling performance.
- In heating mode, the outdoor unit will produce condensate water. This condensate needs to be properly drained to waste in accordance with all applicable local and national plumbing regulations.
- Select unit location where it will not be subject to the accumulation of snow, leaves or other seasonal debris. This may negatively impact the performance and longevity of the units.
- Locate the outdoor unit as close as possible to the indoor unit to reduce performance losses.

- If possible, please remove any obstacles nearby to prevent the system performance being negatively impacted by compromised condenser air circulation.
- The minimum distance between the outdoor unit and walls/obstacles described in the installation chart does not correlate directly to installations in enclosed spaces. In these cases at least two of the three sides should remain open (M, N, P). Refer to "Figure 8." on page 48

DO NOT install unit in the following locations:

- Near an obstacle that will block air inlets and outlets
- Near a public street, crowded areas, or where noise from the unit will disturb others
- Near animals or plants that will be harmed by hot air discharge
- Near any source of combustible gas
- In a location that is exposed to large amounts of dust
- In a location exposed to excessive amounts of salty air

SPECIAL CONSIDERATIONS FOR EXTREME WEATHER

If the unit is exposed to heavy wind

Install unit so that air outlet fan is at a 90° angle to the direction of the wind. If needed, build a barrier in front of the unit to protect it from extremely heavy winds. Refer to Figure 9 below.

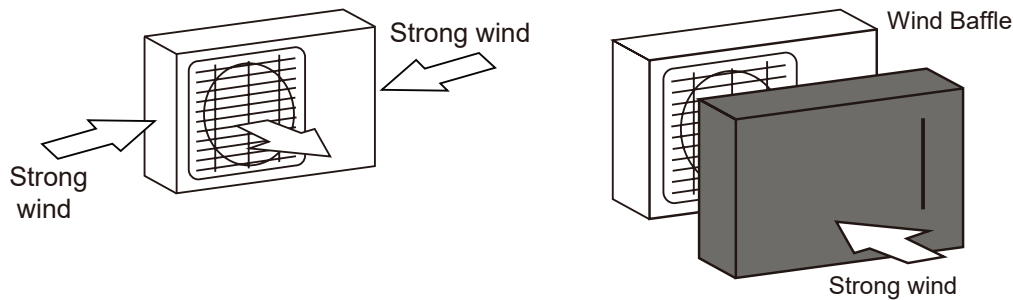

Figure 9.



If the unit is frequently exposed to heavy rain or snow:

- **Build a shelter above the unit to protect it from the rain or snow. Be careful not to obstruct air flow around the unit.**

If the unit is frequently exposed to salty air (seaside):

- **Use outdoor unit that is specially designed to resist corrosion.**

Step 2. Install drain joint (Heat pump unit only)

Before bolting the outdoor unit in place, you must install the drain joint at the bottom of the unit. Note that there are two different types of drain joints depending on the type of outdoor unit.

If the drain joint comes with a rubber seal (see Figure 10), do the following:

- Fit the rubber seal on the end of the drain joint that will connect to the outdoor unit.
- Insert the drain joint into the hole in the base pan of the unit.
- Rotate the drain joint 90° until it clicks in place facing the front of the unit.
- Connect a drain hose extension (not included) to the drain joint to redirect water from the unit during heating mode.

OUTDOOR INSTALLATION

If the drain joint doesn't come with a rubber seal (see Figure 11), do the following:

- Insert the drain joint into the hole in the base pan of the unit. The drain joint will click in place.
- Connect a drain hose extension (not included) to the drain joint to redirect water from the unit during heating mode.

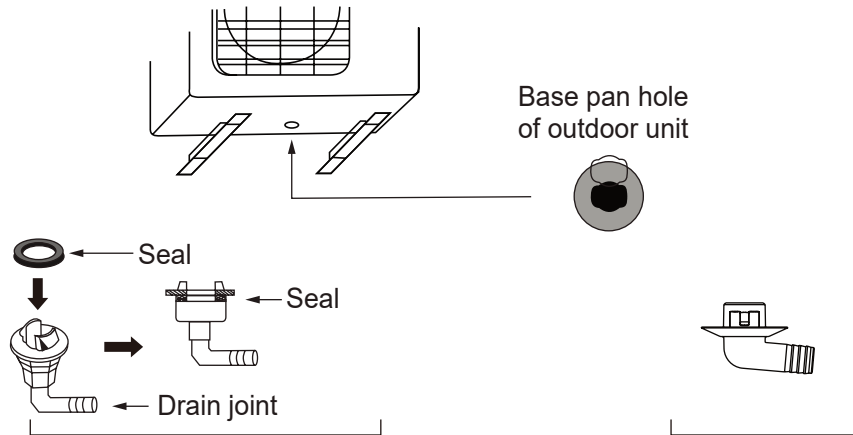

Figure 10.

Figure 11.



The condensate drain terminal point must comply with Local Regulations and Municipal Building codes or refer to AS/NZS 3500 Plumbing and Drainage.



IN COLD CLIMATES

Always turn off the power to your air conditioner system and isolate its power supply before you perform any cleaning or maintenance; otherwise it may cause electric shock.

In cold climates, make sure that the drain hose is as vertical as possible to ensure swift water drainage. If water drains too slowly, it can freeze in the hose and flood the unit. Insulating the drain hose in cold climates is recommended.

Step 3. Anchor outdoor unit

The outdoor unit can be anchored to the ground or to a wall-mounted bracket with bolt (M10). Prepare the installation base of the unit according to the dimensions on the following page.



To reduce the transmission of vibration and noise, waffle pad shall be installed beneath the unit at each anchor point.

UNIT MOUNTING DIMENSIONS

The following is a list of different outdoor unit sizes and the distance between their mounting feet. Prepare the installation base of the unit according to the dimensions below.

Size kW	Outdoor Unit Dimensions (mm) W x D x H	Mounting Dimensions (mm)	
		Distance A	Distance B
7	890 x 342 x 673	663	354
9 /11	946 x 410 x 810	673	403
13	980 x 415 x 975	616	397
18	952 x 1333 x 415	634	404

**Split Type Outdoor Unit
Types & Specifications**

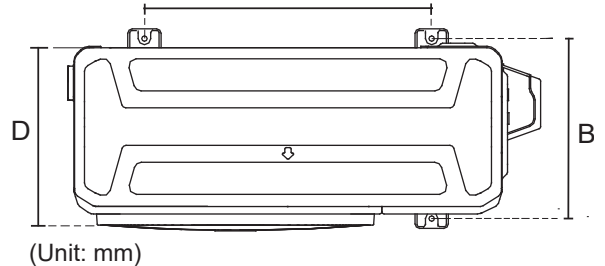
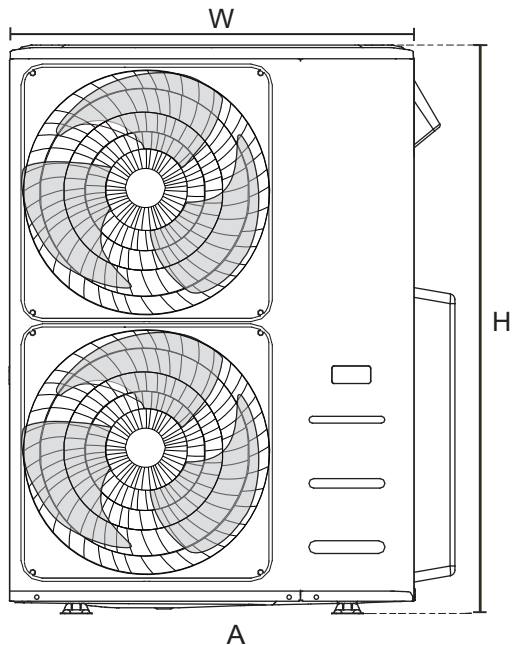
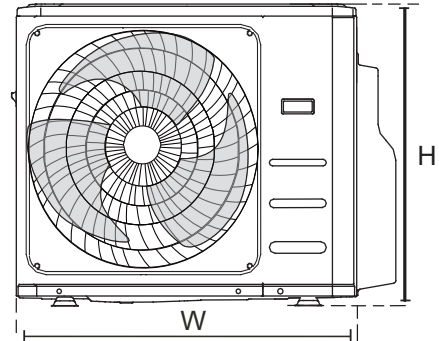

ROWS OF SERIES INSTALLATION

The relations between H, A and L are as follows:

	L	A
L ≤ H	L ≤ 1/2H	25 cm or more
	1/2H < L ≤ H	30 cm or more
L > H	Can not be installed	

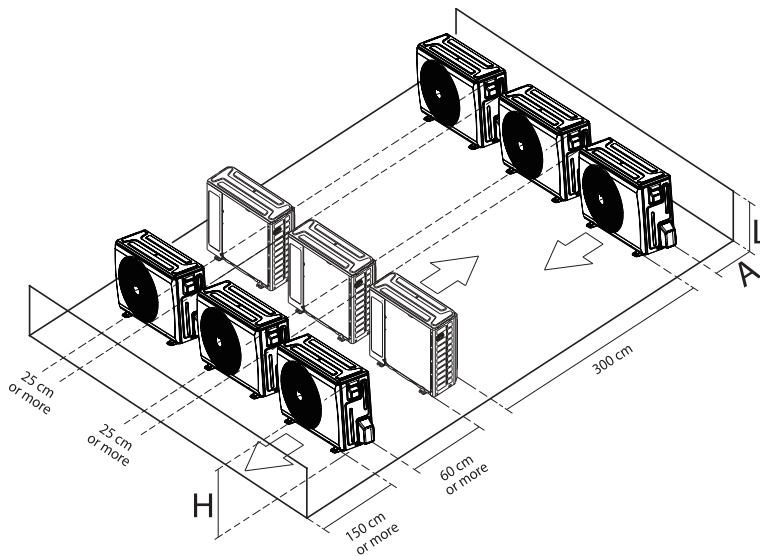

DRILLING HOLE IN WALL

You must drill a hole in the wall for the refrigerant piping, and the signal cable that will connect the indoor and outdoor units.

1. Determine the location of the wall hole based on the location of the outdoor unit.
2. Using a 65-mm core drill, drill a hole in the wall.
3. Place the protective wall cuff in the hole. This protects the edges of the hole and helps seal it when you finish the installation process.



When drilling the wall hole, make sure to avoid wires, plumbing, and other sensitive components.

WHEN SELECTING A 7.0KW & 8.0KW INDOOR UNIT

The 7.0kW & 8.0kW indoor unit can only be connected with an A circuit.

Connective pipe size of an A and B circuit

Indoor Unit capacity (kW)	(Unit mm)	
	Liquid	Gas
2.0 / 2.6 / 3.5	6.35	9.53
3.5 / 5.0 / 6.0	6.35	12.70
7.0 / 8.0	9.53	15.88

- If the outdoor unit is installed on roof structures or external walls, this may result in excessive noise and vibration, it may also be classed as a non serviceable installation, and void the manufacturers warranty.

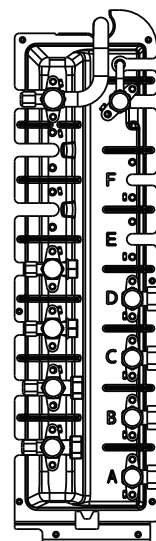

The largest system to be connected to Circuit A

REFRIGERANT PIPING CONNECTION



For quick-connect models, please refer to the Indoor Unit manual for the installation method of refrigerant piping connection. The Outdoor Unit manual does not repeat the instructions.

When connecting refrigerant piping, **DO NOT** let substances or gases other than the specified refrigerant enter the unit. The presence of other gases or substances will lower the unit's capacity, and can cause abnormally high pressure in the refrigeration cycle. This can cause explosion and injury.



The branching pipe must be installed horizontally. An angle of more than 10° may cause malfunction.

DO NOT install the connecting pipe until both indoor and outdoor units have been installed.

Insulate both the gas and liquid piping to prevent condensing.

Step 1. Cut pipes

When preparing refrigerant pipes, take extra care to cut and flare them properly. This will ensure efficient operation and minimise the need for future maintenance.

- Measure the distance between the indoor and outdoor units.
- Using a pipe cutter, cut the pipe a little longer than the measured distance.
- Make sure that the pipe is cut perfectly at a 90° angle.

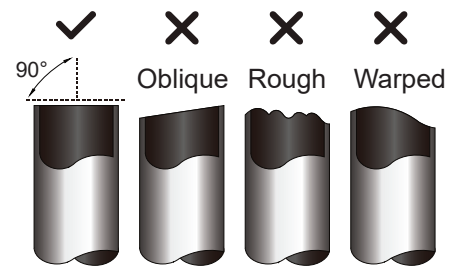

DO NOT DEFORM PIPE WHILE CUTTING.

Be extra careful not to damage, dent, or deform the pipe while cutting. This will drastically reduce the heating efficiency of the unit.

Step 2. Remove burrs

Burrs can affect the air-tight seal of refrigerant piping connection. They must be completely removed.

- Hold the pipe at a downward angle to prevent burrs from falling into the pipe.
- Using a reamer or deburring tool, remove all burrs from the cut section of the pipe.

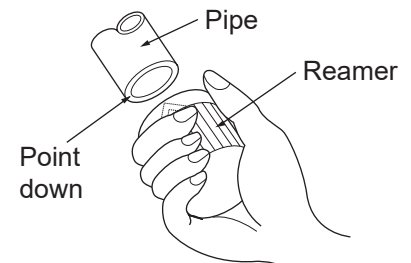

Step 3. Flare pipe ends

Proper flaring is essential to achieve an airtight seal.

- After removing burrs from cut pipe, seal the ends with PVC tape to prevent foreign materials from entering the pipe.
- Sheath the pipe with insulating material.
- Place flare nuts on both ends of pipe. Make sure they are facing in the right direction, because you can't put them on or change their direction after flaring.
- Remove PVC tape from ends of pipe when ready to perform flaring work.
- Clamp flare form on the end of the pipe. The end of the pipe must extend beyond the flare form.
- Place flaring tool onto the form.
- Turn the handle of the flaring tool clockwise until the pipe is fully flared. Flare the pipe in accordance with the dimensions.

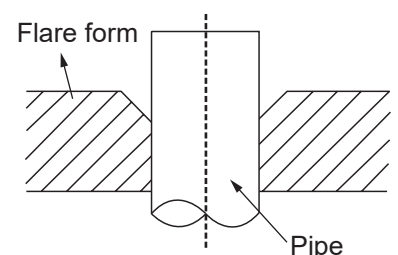
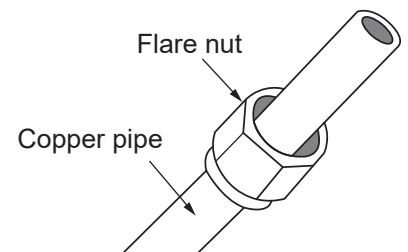

Piping Extension Beyond Flare Form

Pipe gauge	Tightening Torque	Flare dimensions (A) mm		Flare shape
		Min.	Max.	
Ø 6.4	18 - 20 N.m	8.4	8.7	
Ø 9.5	25 - 26 N.m	13.2	13.5	
Ø 12.7	35 - 36 N.m	16.2	16.5	
Ø 15.9	45 - 47 N.m	19.2	19.7	
Ø 19.1	65 - 67 N.m	23.2	23.7	
Ø 22	75 - 85 N.m	26.4	26.9	

- Remove the flaring tool and flare form, then inspect the end of the pipe for cracks and even flaring

Step 4. Connect pipes

Connect the copper pipes to the indoor unit first, then connect it to the outdoor unit. You should first connect the low-pressure pipe, then the high-pressure pipe.

- When connecting the flare nuts, apply a thin coat of compatible refrigeration oil to the flared ends of the pipes.
- Align the centre of the two pipes that you will connect.

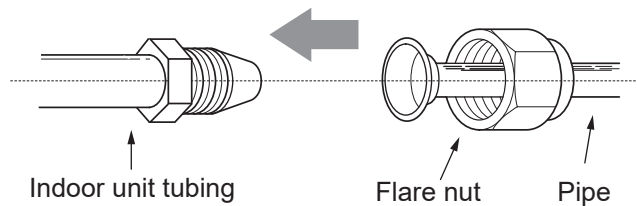

- Tighten the flare nut as tightly as possible by hand.
- Using a spanner, grip the nut on the unit tubing.
- While firmly gripping the nut, use a torque wrench to tighten the flare nut according to the torque values in the table above.

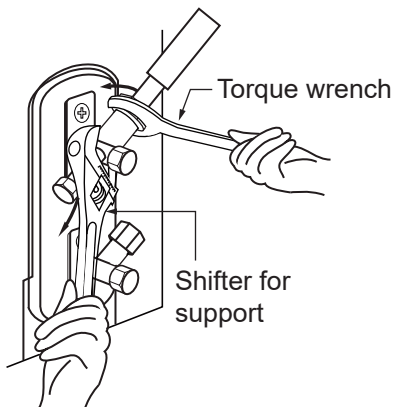

Use both a spanner and a torque wrench when connecting or disconnecting pipes to or from the unit.



Ensure to wrap insulation around the piping. Direct contact with the bare piping may result in burns or frostbite.

Make sure the pipe is connected correctly. Over tightening may damage the bell mouth and under tightening may lead to leakage.

**MINIMUM BEND RADIUS**

Carefully bend the tubing in the middle according to the diagram below. **DO NOT** bend the tubing more than 90° or more than 3 times.

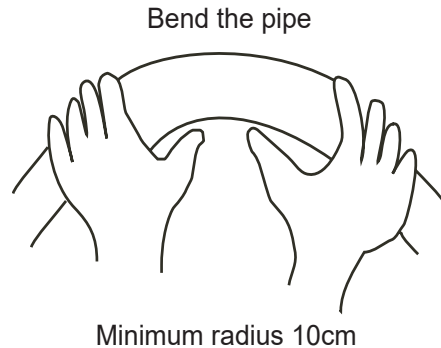

Hands shown are for representation purpose only.

After connecting the copper pipes to the indoor unit, wrap the power cable, signal cable and the piping together with the binding signal tape.



DO NOT intertwine or cross the signal cable with other wires, while bundling these items together.

- Pipe run must be supported every 2m
- R32 flammable refrigerant labels must be placed on the pipe run every 2m
- Thread this pipeline through the wall and connect it to the outdoor unit.
- Insulate all the piping, including the valves of the outdoor unit.
- Open the stop valves of the outdoor unit to start the flow of the refrigerant between the indoor and outdoor unit.



Check to make sure there is no refrigerant leak after completing the installation work. If there is a refrigerant leak, ventilate the area immediately and evacuate the system (refer to the "Air Evacuation" on page 44 of this manual).

WIRING



BEFORE PERFORMING ANY ELECTRICAL WORK, READ THESE REGULATIONS

- All wiring **MUST** comply with local and national electrical codes, regulations and **MUST** be installed by a licensed electrician.
- All electrical connections **MUST** be made according to the Electrical Connection Diagram located on the panels of the indoor and outdoor units.
- If there is a serious safety issue with the power supply, stop work immediately. Explain your reasoning to the client, and refuse to install the unit until the safety issue is properly resolved.
- Power voltage should be within 90-110% of rated voltage. Insufficient power supply can cause malfunction, electrical shock, or fire.
- If connecting power to fixed wiring, a surge protector and main power switch should be installed.
- If connecting power to fixed wiring, a switch or circuit breaker that disconnects all poles and has a contact separation of at least 1 /Bin (3mm) must be incorporated in the fixed wiring. The qualified technician must use an approved circuit breaker or switch.
- Only connect the unit to an individual branch circuit outlet. **DO NOT** connect another appliance to that outlet.
- Make sure to correctly earth the air conditioner.
- Every wire **MUST** be firmly connected. Loose wiring can cause the terminal to overheat, resulting in product malfunction and possible fire.
- **DO NOT** let wires touch or rest against refrigerant tubing, the compressor, or any moving parts within the unit.
- If the unit has an auxiliary electric heater, it **MUST** be installed at least 1 metre (40in) away from any combustible materials.
- To avoid getting an electric shock, **NEVER** touch the electrical components soon after the power supply has been turned off. After turning off the power, always wait 10 minutes or more before you touch the electrical components.
- Make sure that you **DO NOT** cross your electrical wiring with your signal wiring. This may cause distortion and interference.
- The unit **MUST** be connected to the main outlet. Normally, the power supply must have a impedance of 32 ohms.
- No other equipment should be connected to the same power circuit.
- Connect the outdoor wires before connecting the indoor wires.



BEFORE PERFORMING ANY ELECTRICAL OR WIRING WORK, TURN OFF THE MAIN POWER TO THE SYSTEM.



The diagrams and schematics are for explanation purpose only. Your machine may be slightly different. The actual shape shall prevail.

Wiring Appliance

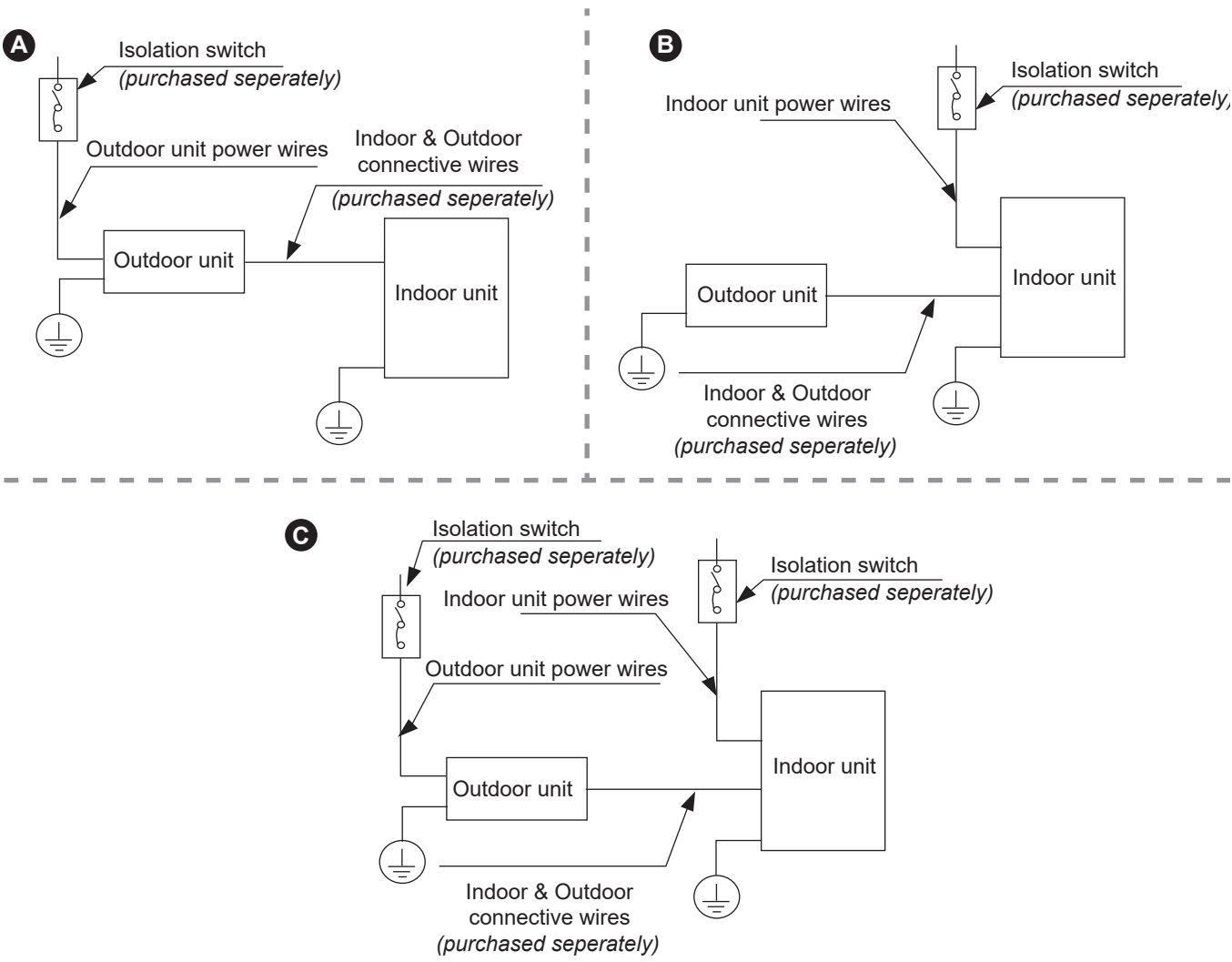

Choose the cable type according to the local electrical codes and regulations.

OUTDOOR UNIT WIRING

1. Prepare the cable for connection following current electrical standards AS/NZS 3000.

Minimum Cross-Sectional Area of Power and Signal Cables (for reference)

Rated Current of Appliance (A)	Nominal Cross-Sectional Area (mm ²)
> 3 and ≤ 6	0.75
> 6 and ≤ 10	1
> 10 and ≤ 16	1.5
> 16 and ≤ 25	2.5
> 25 and ≤ 32	4
> 32 and ≤ 40	6

Choose the right cable size

The size of the power supply cable, signal cable, fuse, and switch needed is determined by the maximum current of the unit. The maximum current is indicated on the nameplate located on the side panel of the unit. Refer to this nameplate to choose the right cable, fuse, or switch.

WIRING

- Using wire strippers, strip the rubber jacket from both ends of the signal cable to reveal approximately 15cm of wire.
- Strip the insulation from the ends.
- Using a wire crimper, crimp u-lugs on the ends.



When connecting the wires, strictly follow the wiring diagram found inside the electrical box cover.

2. Remove the electric cover of the outdoor unit. If there is no cover on the outdoor unit, take off the bolts from the maintenance board and remove the protection board (see figure below of outdoor unit).

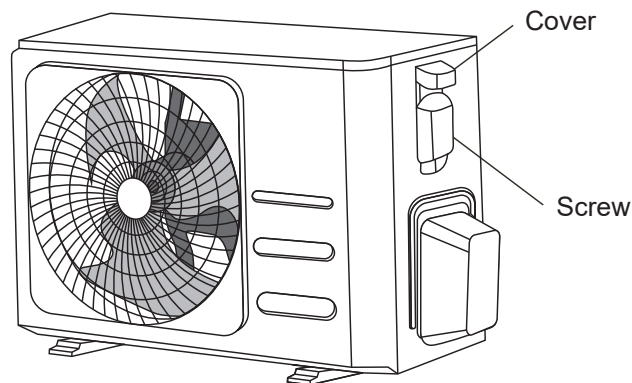

3. Connect the u-lugs to the terminals. Match the wire colours/labels with the labels on the terminal block. Firmly screw the u-lug of each wire to its corresponding terminal.
4. Clamp down the cable with the cable clamp.
5. Insulate unused wires with electrical tape. Keep them away from any electrical or metal parts.
6. Reinstall the cover of the electric control box.

OUTDOOR UNIT WIRING DIAGRAM



Please refer to the following diagrams for the wiring connections for the various models. Please run the main power cord through the lower line-outlet of the cord clamp.

ONE OUTDOOR - THREE INDOOR UNITS

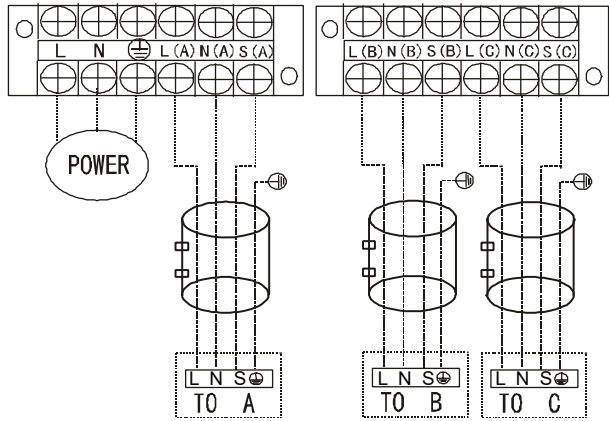

ONE OUTDOOR - FOUR INDOOR UNITS

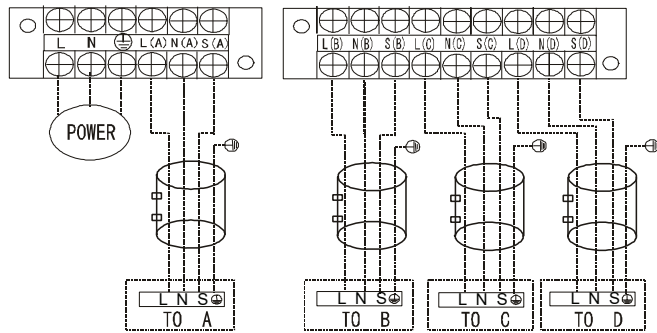

ONE OUTDOOR - FIVE INDOOR UNITS

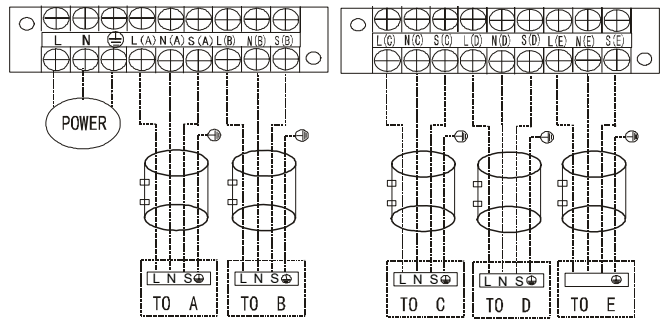

CAUTION

- 1) An individual power circuit must be used for this system. Wiring shall be conducted in accordance with the unit circuit diagram & these instructions.
- 2) The screws which fasten the wiring within the electrical switchboard may come loose from vibration in transportation. Please ensure that all electrical connections within the unit are sufficiently tightened. Loose connections may cause overheating at the terminals, leading to an electrical failure or malfunction.
- 3) Confirm the suitability of the power source.
- 4) Confirm that electrical capacity is sufficient for the operating current of the system.
- 5) Ensure that the starting voltage is maintained at more than 90 percent of the rated voltage marked as marked on the name plate.
- 6) Confirm that the cable thickness is suitable for the power source specification.
- 7) Always use an adequately sized circuit breaker.
- 8) The issues which may cause voltage drop are for example: vibration/chattering of contractors which will damage the contact points or blown fuses breaking, overload and/or malfunction of the system.
- 9) Before accessing the electrical terminals, disconnect all power from the system.

Compressor / Power Supply Information

Compressor start/stop	Stop time	Min 3 minutes
Power supply voltage	Voltage variance	Within +/- 10% of supply voltage
	Voltage drop	Within +/- 15% of supply voltage
	Voltage imbalance	Within +/- 3% of supply voltage



To satisfy the EMC compulsory regulations, which is required by the international standard CISP 14-1:2005/A2:2011 or AS/NZS 61000.6.3 in specific countries or districts, please make sure you apply the correct magnetic rings on your equipment according to the wiring diagram that adheres to your equipment. Please contact your distributor or installer to get further information and purchase magnetic rings (The supplier of magnetic ring is TDK (model ZCAT3035-1330) or similar).

PRESSURE & LEAK TEST

DRY NITROGEN PRESSURE TEST

- Using dry nitrogen, pressure test interconnecting pipework from outdoor unit inclusive of fan coil unit, to the 'Maximum Allowable Pressure' as indicated on the product label of the outdoor unit. For more information, refer to AS/NZS 5149.2.

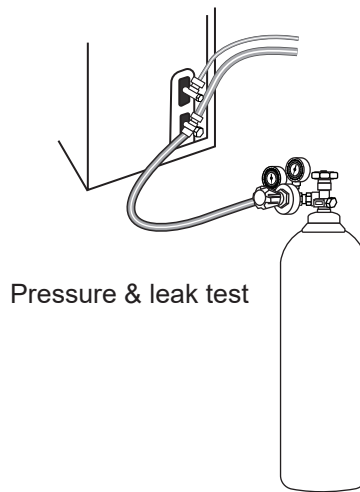

Air, Oxygen, Acetylene or refrigerants shall not be used for pressure testing purposes.

LEAK TESTING INSTRUCTIONS

- Outdoor unit service ports shall be closed or front seated before commencing.
- Connect Dry Nitrogen bottle with gauge set to the suction line access point and ensure all fittings are tight.
- Open the Dry Nitrogen bottle valves and set test pressure to 'Maximum Allowable Pressure' as indicated on the outdoor specification label, **do not exceed**.
- Use an approved 'Bubble Leak Detector' to assess all joints for leaks, from the outdoor service valves to the connections at the indoor unit.
- If no leaks are detected close the Dry Nitrogen valves.
- With care, safely and slowly commence removal of the pressure supply line from the Dry Nitrogen bottle using the bleed to release technique.
- Once the system pressure has been removed safely you may remove the connecting line from service valve on the appliance..



DO NOT exceed the 'Maximum Allowable Pressure' as this may damage system components which is not covered under warranty.



Wear the correct PPE at all times when working with refrigerants and conducting high pressure tests.

AIR EVACUATION

PREPARATIONS AND PRECAUTIONS

Air and foreign matter in the refrigerant circuit can cause abnormal rises in pressure, which can damage the air conditioner, reduce its efficiency, and cause injury. Use a vacuum pump and manifold gauge to evacuate the refrigerant circuit, removing any non-condensable gas and moisture from the system.

Evacuation **MUST** be performed upon initial installation and when unit is relocated.

Before Performing Evacuation

- Check to make sure the connective pipes between the indoor and outdoor units are connected correctly.
- Check to make sure all wiring is connected correctly.

EVACUATION INSTRUCTIONS

Before using a manifold gauge and a vacuum pump, read their operation manuals to make sure you know how to use them properly.

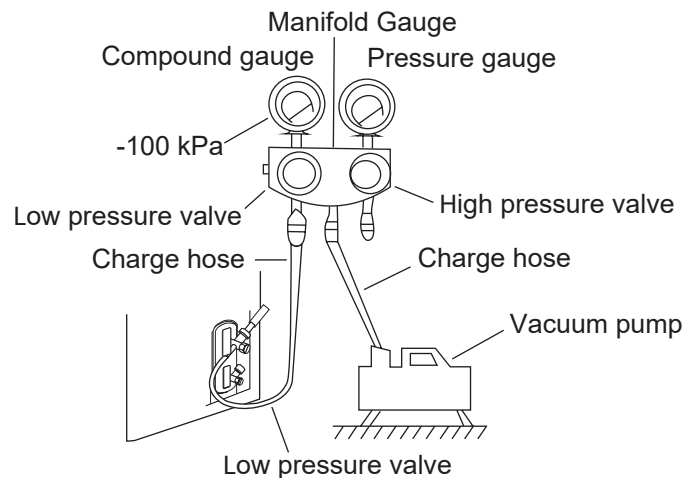

1. Connect the manifold gauge's charge hose to the service port on the outdoor unit's low pressure valve.
2. Connect the manifold gauge's charge hose from the to the vacuum pump.
3. Open the Low Pressure side of the manifold gauge. Keep the High Pressure side closed.
4. Turn on the vacuum pump to evacuate the system.
5. Run the vacuum for at least 30 minutes, or until the Compound Meter reads -100 kPa.
6. Close the manifold gauge's Low Pressure valve and turn off the vacuum pump.
7. Wait for 5 minutes, then check that there has been no change in system pressure..



If there is no change in system pressure, unscrew the cap from the packed valve (high pressure valve). If there is a change in system pressure, there may be a gas leak.

8. Insert hexagonal wrench into the packed valve (high pressure valve) and open the valve by turning the wrench 1/4 counter-clockwise. Listen for gas to exit the system, then close the valve after 5 seconds.

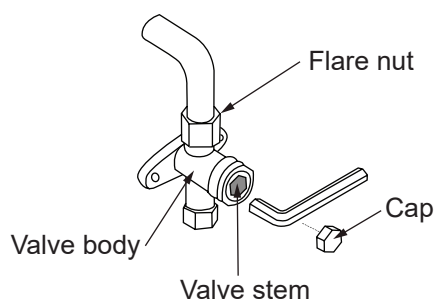

9. Watch the Pressure Gauge for one minute to make sure that there is no change in pressure. It should read slightly higher than the atmospheric pressure.

10. Remove the charge hose from the service port.
11. Using hexagonal wrench, fully open both the high pressure and low pressure valves.



OPEN VALVE STEMS GENTLY

When opening valve stems, turn the hexagonal wrench anti-clockwise until it hits against the back stop. **DO NOT** try to force the valve to open further.



Check to make sure there is no refrigerant leak after completing the installation work. If there is a refrigerant leak, ventilate the area immediately and evacuate the system.

12. After opening up the service valve stems to allow the refrigerant to flow throughout the system please apply leak search solution to ensure the service valve spindles are not leaking. If service valve spindles are leaking front and back seat them several times to readjust the seal behind the valve stem. Apply Nylog leak lock onto the threaded fittings before service valve caps are placed onto the service valves.
13. Tighten valve caps by hand, then tighten it using the proper tool.
14. If the outdoor unit uses all vacuum valves, and the vacuum position is at the main valve, the system is not connected with the indoor unit. The valve must be tightened with a screw nut. Check for gas leaks before operation to prevent leakage.
15. After removing your refrigeration gauges of the system, please apply leak search solution to ensure the schrader valve cores are not leaking. Apply Nylog leak lock onto the threaded fittings before schrader valve caps are placed onto the service valves ports.

ADDING REFRIGERANT



Refrigerant charging must be performed after wiring, vacuuming, and the leak testing.

DO NOT exceed the maximum allowable quantity of refrigerant or overcharge the system. Doing so can damage the unit or impact it's functioning.

Charging with unsuitable substances may cause explosions or accidents. Ensure that the appropriate refrigerant is used.

Refrigerant containers must be opened slowly. Always use protective gear when charging the system.

DO NOT mix refrigerant types.

For R32 refrigerant model, make sure the conditions within the area have been made safe by control of flammable material when the refrigerant added into the air conditioner

N=3 (3 Head models), N=4 (4 Head models), N=5 (5 Head models).

Depending on the length of connective piping or the pressure of the evacuated system, you may need to add refrigerant. Refer to the table below for refrigerant amounts to be added.

Additional Refrigerant per pipe length

Connective Pipe Length (m)	Air Purging Method	Additional Refrigerant (R32)	
Less than Standard pipe length x N	Vacuum Pump	N/A	
More than Standard pipe length x N	Vacuum Pump	Liquid Side: Ø 6.35 (mm) (Total pipe length - pre-charge pipe length x N) x15g/m	Liquid Side: Ø 9.52 (mm) (Total pipe length - pre-charge pipe length x N) x30g/m

Make sure to remove the additional refrigerant charge according to the rated volume (5mrefrigerant piping) when doing market or government verification test.



The standard pipe length is 10m.

SAFETY AND LEAKAGE CHECK

Electrical safety check

Perform the electrical safety check after completing installation. Covering the following areas:

1. **Insulated resistance**
The insulated resistance must be more than 2 Ohm.
2. **Earthing work**
After finishing earthing work, measure the earthing resistance by visual detection and using the earthing resistance tester.
Make sure the earthing resistance is less than 4 Ohm.
3. **Electrical leakage check** (performing during test while unit is on).
During a test operation after completed installation, the use the electro-probe and multimeter to perform an electrical leakage check. Turn off the unit immediately if leakage happens. Try and evacuate different solutions until the unit operates properly.

Gas leak check

1. **Soap water method**
Apply a soap-water solution or a liquid neutral detergent on the indoor unit connection or outdoor unit connections with a soft brush to check for leakage of the connecting points of the piping. If bubbles emerge, the pipes are experiencing leakage.
2. **Leak detector**
Use the leak detector to check for leakage.

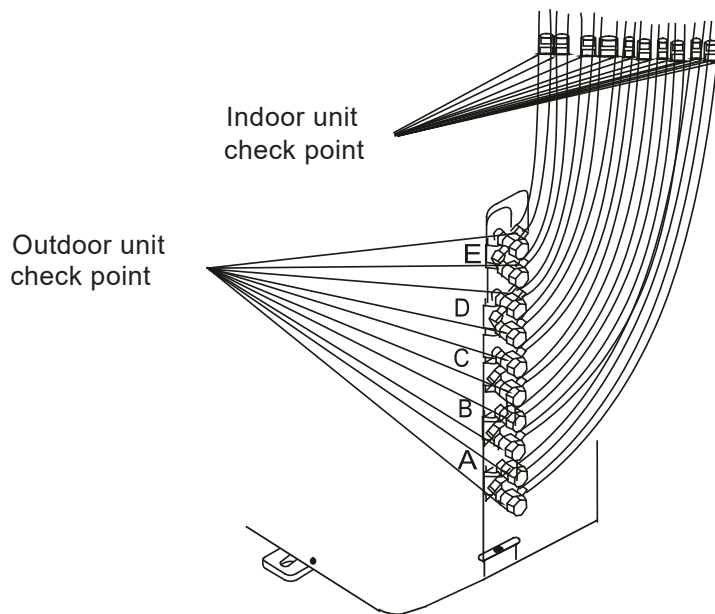

A, B, C, D are points for the 4 head model
A, B, C, D and E are points for the 5 head model



The illustration is an example only. The actual order of A, B, C, D, and E on the model may be slightly different from the unit you purchased but the general shape will remain the same.

BEFORE TEST RUN

A test run must be performed after the entire system has been completely installed. Confirm the following points before performing the test:

- a) Indoor and outdoor units are properly installed.
- b) Piping and wiring are properly connected.
- c) No obstacles near the inlet and outlet of the unit that might cause poor performance or product malfunction.
- d) Refrigeration system does not leak.
- e) Drainage system is unimpeded and draining to a safe location.
- f) Heating insulation is properly installed.
- g) Earthing wires are properly connected.
- h) Length of the piping and additional refrigerant stow capacity have been recorded.
- i) Power voltage is the correct voltage for the air conditioner.



Failure to perform the test run may result in unit damage, property damage, or personal injury.

TEST RUN INSTRUCTIONS

1. Ensure both the liquid and gas stop valves are open.
2. Turn on the main power switch and allow the unit to warm up.
3. Set the air conditioner to COOL mode.
4. **For the Indoor Unit**
 - a) Ensure the remote controller buttons work properly.
 - b) Ensure the louvers move properly and can be changed using the remote control.
 - c) Double check to see if the room temperature is being registered correctly.
 - d) Ensure the indicators on the remote controller and the display panel on the indoor unit work properly.
 - e) Ensure the manual buttons on the indoor unit works properly.
 - f) Check to see that the drainage system is unimpeded and draining smoothly.
 - g) Ensure there is no vibration or abnormal noise during operation.
5. **For the Outdoor Unit**
 - a) Check to see if the refrigeration system is leaking.
 - b) Make sure there is no vibration or abnormal noise during operation.
 - c) Ensure the wind, noise, and water generated by the unit do not disturb your neighbours or pose a safety hazard.



If the unit malfunctions or does not operate according to your expectations, please refer to the Troubleshooting section of the Owner's Manual before calling customer service.

AUTOMATIC CORRECTION FUNCTION

AUTOMATIC WIRING/PIPING CORRECTION FUNCTION

More recent models now feature automatic correction of wiring/piping errors. Press the “check switch” on the outdoor unit PCB board for 5 seconds until the LED displays “CE”, indicating that this function is working. Approximately 5-10 minutes after the switch is pressed, the “CE” disappears, meaning that the wiring/piping error is corrected and all wiring/piping is properly connected.

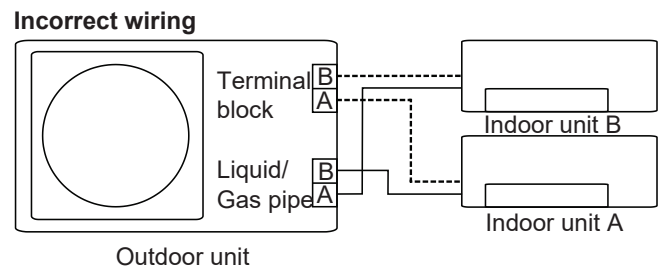
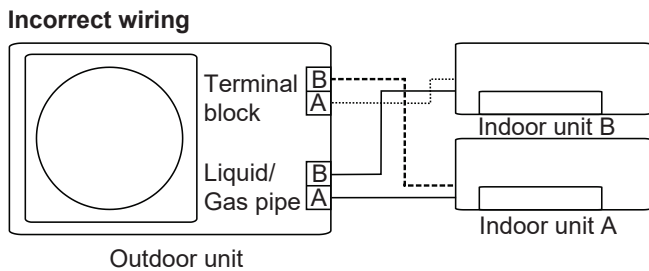
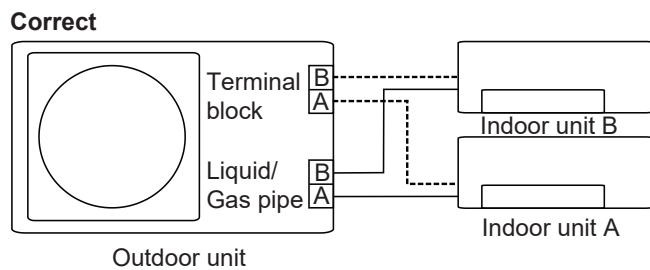
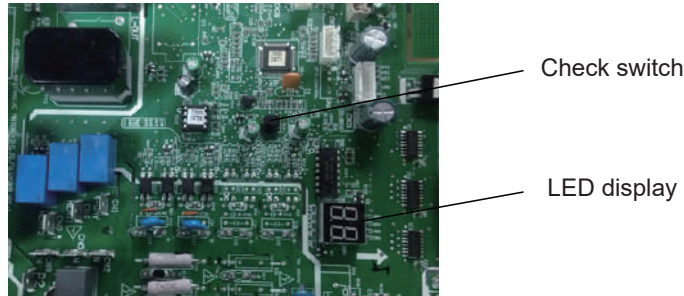

How To Activate This Function

1. Check that outside temperature is above 5°C.
(This function does not work when outside temperature is not above 5°C)
2. Check that the stop valves of the liquid pipe and gas pipe are open.
3. Turn on the breaker and wait at least 2 minutes.
4. Press the check switch on the outdoor PCB board unit LED display “CE”.

COMMISSIONING

COMMISSIONING CHECKLIST

Installer to please complete all sections of this form.

System Information

Model (Outdoor Unit)		Serial No. (Outdoor Unit)	
Model (Indoor Unit)		Serial No. (Indoor Unit)	
Model		Serial No.	
Installed by / Date			

Pre Start-Up

(Please tick boxes below as each item is completed).

<input type="checkbox"/>	Verify that all packaging materials have been removed from the unit.
<input type="checkbox"/>	Remove all shipping hold down bolts and brackets, as per installation instructions.
<input type="checkbox"/>	Check that condensate connection is installed, as per installation instructions.
<input type="checkbox"/>	Check all electrical connections and terminals for tightness.
<input type="checkbox"/>	Check that indoor return air filter is clean and in place.
<input type="checkbox"/>	Verify that unit installation is level.
<input type="checkbox"/>	Check fans for alignment and noise

Operation Characteristics

(Please record the following data after at least 20 minutes running time).

Suction Pressure		kPa
Suction Line Temperature		°C
Discharge Pressure		kPa
Liquid Line Temperature		°C
Superheat		K
Sub-Cooling		K
Compressor Amps (L1)		A
Compressor Amps (L2 for 3 phase)		A
Compressor Amps (L3 for 3 phase)		A
Indoor Coil Air On (Return) Temperature		°C DB
Indoor Coil Air On (Supply) Temperature		°C DB
Outdoor Air Temperature (Ambient)		°C DB
Length of Liquid Line		m
Length of Suction Line		m
Liquid Line Diameter		mm
Suction Line Diameter		mm
Extra refrigerant quantity charged (if any)		kg
Supply Voltage		V
Actual Voltage		V

Rinnai Australia Pty Ltd

ABN 74 005 138 769 | AU45204

100 Atlantic Drive, Keysborough, Victoria 3173
P.O. Box 460, Braeside, Victoria 3195
Tel: (03) 9271 6625

National Help Line

Tel: 1300 555 545*

Monday to Friday, 8.00 am to 5.00 pm EST.

**Cost of a local call may be higher from a mobile phone.
(National calls from public phones in Australia are free.)*

For further information visit **www.rinnai.com.au**
or email **enquiry@rinnai.com.au**

Rinnai has a Service and Spare Parts network with personnel who are fully trained and equipped to give the best service on your Rinnai appliance. If your appliance requires service, please call our National Help Line. Rinnai recommends that this appliance be serviced once a year.

With our policy of continuous improvement, we reserve the right to change, or discontinue at any time, specifications or designs without notice.