

CONTACT RINNAI COMMERCIAL FOR CIRCULATION DESIGN

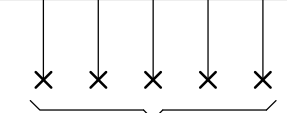

SINGLE & DUAL CIRCULATION PUMPS OPTIONAL (NOT INCLUDED) GPO'S REQUIRED

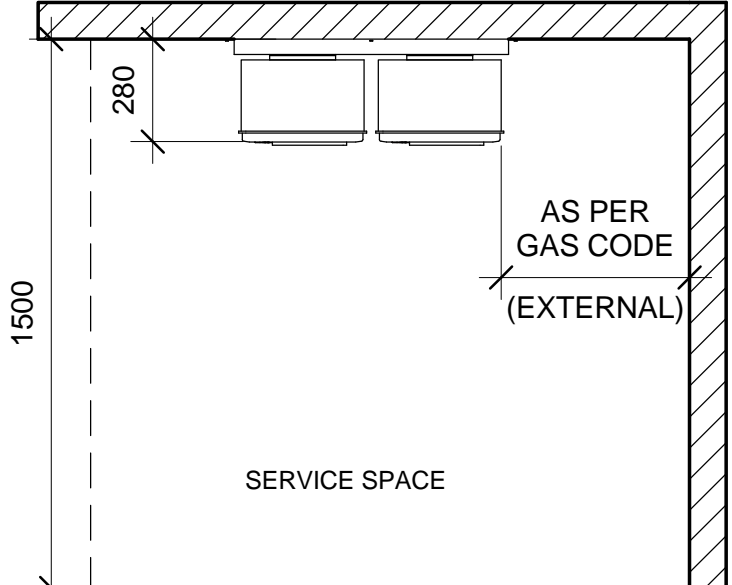
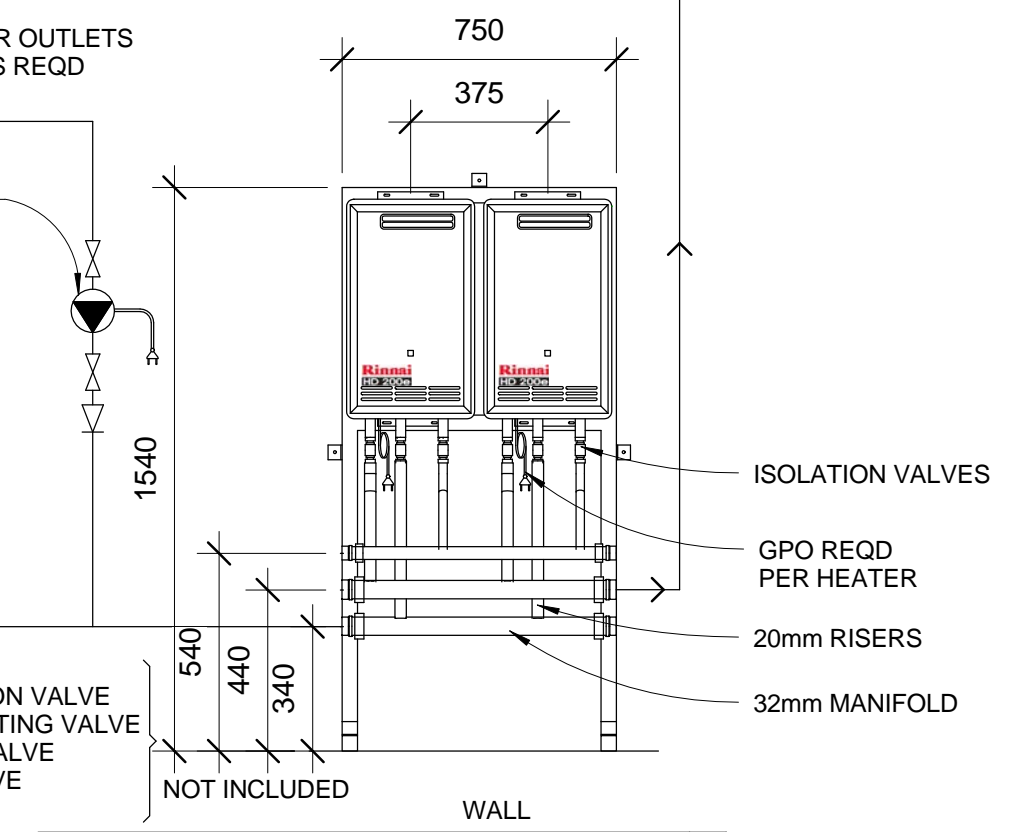
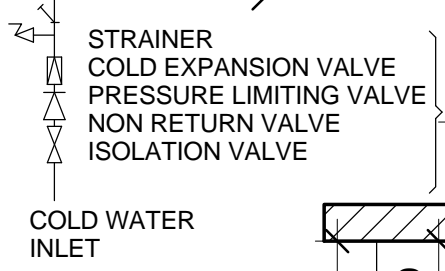

* COLD EXPANSION VALVE & NON RETURN VALVE NOT REQUIRED ON NON CIRCULATING SYSTEMS.

DRAWING CHANGES					
REV	ECN NO	DESCRIPTION	BY	CKD	DATE

WEIGHT:

MP2 - 60 kg

HD200 HEATERS:

GAS LOAD EACH 200MJ
 - NG 1.13 - 2.75 kPa
 - LPG 2.75 kPa
 FAN ASSISTED , BALANCED FLUE

ELECTRICAL:

240 V 10 AMP GPO
 PER HD HEATER

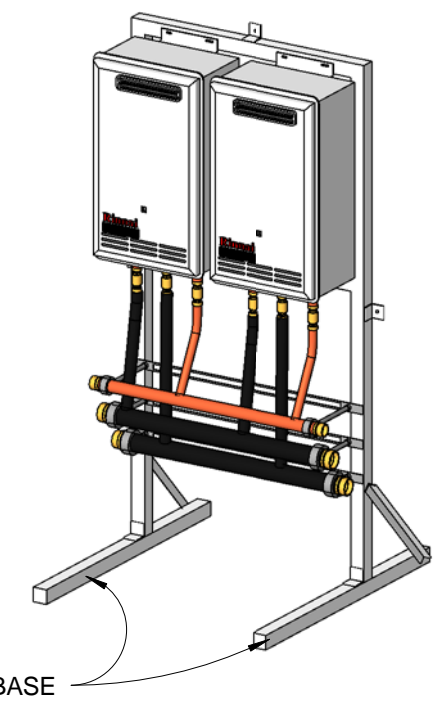

MATERIAL	DRAWN	DAP
TOLERANCE - UNLESS STATED	DATE	21/05/12
0.±1.0 0.0 ±0.5	CHECKED	SVL
0.00 ±0.1 Angular ±1	APPROVED	
FINISH:	DO NOT SCALE DRAWING	

Rinnai Australia Pty Ltd

**DEMAND DUO-MP220OE
 MANIFOLD PACK**

Weight	Drawing Number(PART NO)	Revision
	RA-21-05-12-017	