

Split Solar Hot Water Systems

Operation & Installation Manual

Rinnai

Congratulations on the purchase of your Rinnai Solar Hot Water System. We trust you will have many years of comfort and enjoyment from your appliance.



BEFORE USING THIS APPLIANCE

Before proceeding with the operation or installation read this manual and any other manuals supplied with the system thoroughly and gain a full understanding of the system, to ensure safe and correct use.

This manual covers the installation of the split solar hot water system, excluding the roof installation of the flat plate or evacuated tube collector(s). Full information on the collector installation can be found in the manual provided with the collector installation kit, or on the Rinnai website. www.rinnai.com.au.

Information on the installation and operation of the solar controller is in the separate solar controller manual, or on the Rinnai website. www.rinnai.com.au.

All information and warnings in the relevant collector installation manual are applicable to this installation.

This appliance must be installed in accordance with:

- Manufacturer's Installation Instructions
- Current AS/NZS 3000, AS/NZS 3500 & AS/NZS 5601
- Plumbing Code of Australia (PCA)
- Local Regulations and Municipal Building Codes including local OH&S requirements

These products comply with the lead-free requirements of the National Construction Code – Volume 3.

The solar hot and cold pipes between the solar storage tank and the solar collector(s) must be suited to the high water temperatures and pressures that may occur. Fittings used to join these pipes must use metallic materials to achieve sealing. Plastic pipe and fittings must not be used as they are not suitable for the high temperatures and pressures that may occur.

Failure of plastic pipe and/or fittings can lead to the release of high temperature water and cause severe flooding and water damage.

This appliance must be installed, maintained and removed by an Authorised Person.

For continued safety of this appliance it must be installed and maintained in accordance with the manufacturer's instructions.

Not suitable as a pool or spa heater.



The Australian Gas Association
All Rinnai gas products sold in Australia are A.G.A. certified.



This Appliance complies with current AS 3498 LIC. W169



This Appliance complies with current AS 3498 LIC. W208



AS/NZS 2712 Lic No. 1849

TABLE OF CONTENTS

Warnings and Important Information	5
Regulatory Information	5
Safety	6
Operation Principle	7
System Location	7
Safety Devices	8
Gas Boosters	9
Hydrogen Gas	9
Water Temperature	9
Turning the Water Heating System Off and On	9
Water Quality	10
Maintenance and Regular Care	10
Servicing and Repair	10
Save a Service Call	11
Specifications	14
System	14
Solar Collectors	14
Storage Cylinders	15
Gas Boosters	19
Installation	20
Regulations and Occupation Health and Safety (OH&S)	20
Location	20
Gas Supply	21
Electric Supply	21
Hot Water Temperature	21
Water Pipes, Fittings and Insulation	22
Water Supply	23
Frost Protection Mode	23
Valves and Fittings	23
Components and Installation Diagrams	28
Installation Procedure	38
Filling the System	40
Solar Pump Operation	41
Pre Solar Heating Checks	41
Connect to Electrical Supply	43
Finishing the Installation	45
Draining Instructions	45
Contacts	48

WARNINGS AND IMPORTANT INFORMATION



READ ALL INSTRUCTIONS BEFORE OPERATING THE SYSTEM.

Always comply with the following precautions to avoid dangerous situations and to ensure optimum performance.

Failure to carefully read and follow all instructions in this manual can result in equipment malfunction, property damage, personal injury and/or death. Your Rinnai solar hot water system has been certified by the relevant plumbing and electrical authorities and the details are shown on the data plate.

DANGER: Indicates an imminently hazardous situation which, if not avoided, will result in personal injury or death.

WARNINGS: Indicates a potentially hazardous situation which, if not avoided, could result in personal injury or death.

CAUTIONS: Indicates a potentially hazardous situation which, if not avoided, could result in minor or moderate injury or damage to the appliance. It may also be used to alert against unsafe practices.



REGULATORY INFORMATION

This system shall be installed in accordance with these instructions and all regulatory requirements which exist in your area including those in relation to manual lifting, working at heights and on roofs. Applicable publications and regulations may include:

- AS/NZS 3500 National Plumbing and Drainage
- AS/NZS 3000 Wiring rules
- Plumbing Code of Australia (PCA)
- Building Codes of Australia (BCA)
- Local Occupational Health and Safety (OH&S) regulations
- Local Regulations and Municipal Building Codes

DO NOT operate this system before reading the manufacturers instructions.

This appliance must be installed, commissioned and serviced by an authorised person in accordance with all applicable local rules and regulations.

For continued safety of this appliance it must be installed, operated and maintained in accordance with the manufacturer's instructions.

This system is heavy, use 2 or more people or mechanical lifting device. Improper lifting may result in serious injury.

Take care when opening or unpacking this appliance. Failure to do so may result in serious injury or product failure.

DO NOT modify the electrical wiring of this appliance. If the control power wiring is damaged or deteriorated then it must be replaced by an authorised person. Failure to do so may result in electric shock, fire, serious injury or product failure.

Removal of the access covers of water heating system will expose 240V wiring and **MUST ONLY** be removed by an authorised person.

This appliance is not suitable for use as a domestic spa pool or swimming pool heater.

Please keep this instruction booklet in a safe place for future reference. All dimensions referred to in these instructions are in millimetres, unless otherwise specified.



Notice to Victorian Consumers

This appliance must be installed by a person licensed with the Victorian Building Authority.

Only a licensed person will have insurance protecting their workmanship.

So make sure you use a licensed person to install this appliance and ask for your Compliance Certificate. For further information contact the Victorian Building Authority on 1300 815 127.



SAFETY

This appliance is **NOT** intended for use by persons (including children) with reduced physical, sensory or mental capabilities, or lack of experience and knowledge unless they have been given supervision or instruction concerning use of the appliance by a person responsible for their safety.

Children should be supervised to ensure that they **DO NOT** play with the appliance.

If the power supply cord of any water heating components is damaged, it **MUST** be replaced by an authorised person in order to avoid a hazard, using genuine replacement parts available from Rinnai. Take care not to touch the power plugs with wet hands.

Care should be taken not to touch the pipe work as it may be **HOT!** The pipes between the solar collectors and storage cylinder **MUST** be copper or alternative material pipes that may be supplied by Rinnai. Plastic pipe is **NOT** suited to the water temperatures and pressures that may occur in the system. Components used to join pipes must use metallic materials to achieve sealing.

DO NOT place articles on or against any system components.

DO NOT store chemicals or flammable materials near any system components.

DO NOT operate with covers removed from any system components.

DO NOT activate pump unless cylinder is full of water.

NEVER use a flammable spray such as hair spray, lacquer, paint, etc near this unit as this may cause a fire.



Warning About Hot Water

Hot water can cause scalding. Those most at risk are children and disabled, elderly and infirm persons. (65°C water can severely burn a child in half a second).

Installing tempering valves or thermostatic mixing valves which reduce the hot water temperature delivered to the taps. Your local plumbing authority may already require that these be fitted. Contact your installer or local plumbing authority if in doubt.

ALWAYS test the water temperature before use, such as when filling a bath or basin or entering a shower, to ensure it is suitable for the application and will not cause scald injury.

ALWAYS supervise children whenever they are in the bathroom or near other sources of hot water. Ensure any hot water taps are closed firmly after use.



MANDATORY INSPECTION PRIOR TO INSTALLATION

Immediately report any damage or discrepancies to the Supplier of the appliance. This appliance was inspected and tested at the time of manufacture and packaging, and released for transportation without known damage. Upon receipt, inspect the exterior for evidence of rough handling in shipment. Ensure that the appliance is labelled correctly for the gas and electrical supply, and/or other services it is intended to be connected to.

For safety and warranty purposes, appliances that may be damaged or incorrect **MUST NOT** be installed or operated under any circumstances. Installation of damaged or incorrect appliances may contravene local government regulations. Rinnai disclaims any liability or responsibility whatsoever in relation to the installation or operation of damaged or incorrect appliances.

OPERATION PRINCIPLE

Split solar hot water systems are designed to have the solar collectors (either flat plate or evacuated tubes) on the roof and the storage cylinder installed at ground or floor level.

The system comprises a hot water storage cylinder, solar collectors, pump, controller and temperature sensors, and either gas or electric boosting.

Water is pumped from the storage tank to the solar collectors when there is enough heat available from the sun. The solar controller utilises information from the temperature sensors to manage this process.

Supplementary heating is utilised if insufficient heat is available from the sun (such as during cloudy or rainy weather or during winter months) either via an electric heating element(s) located inside the storage cylinder or via an in-line gas booster located external to the storage cylinder.

Further detail on the system operation is included in the manual supplied with the controller.

The following diagrams illustrate the operation of the system as with both electric and gas boosting.

 **These diagrams are intended to give an overview of the operation principle of a split solar hot water system. They are not intended as an installation guide. Connections on the tank may vary from those shown. The installation diagrams shown later in this manual must be followed.**

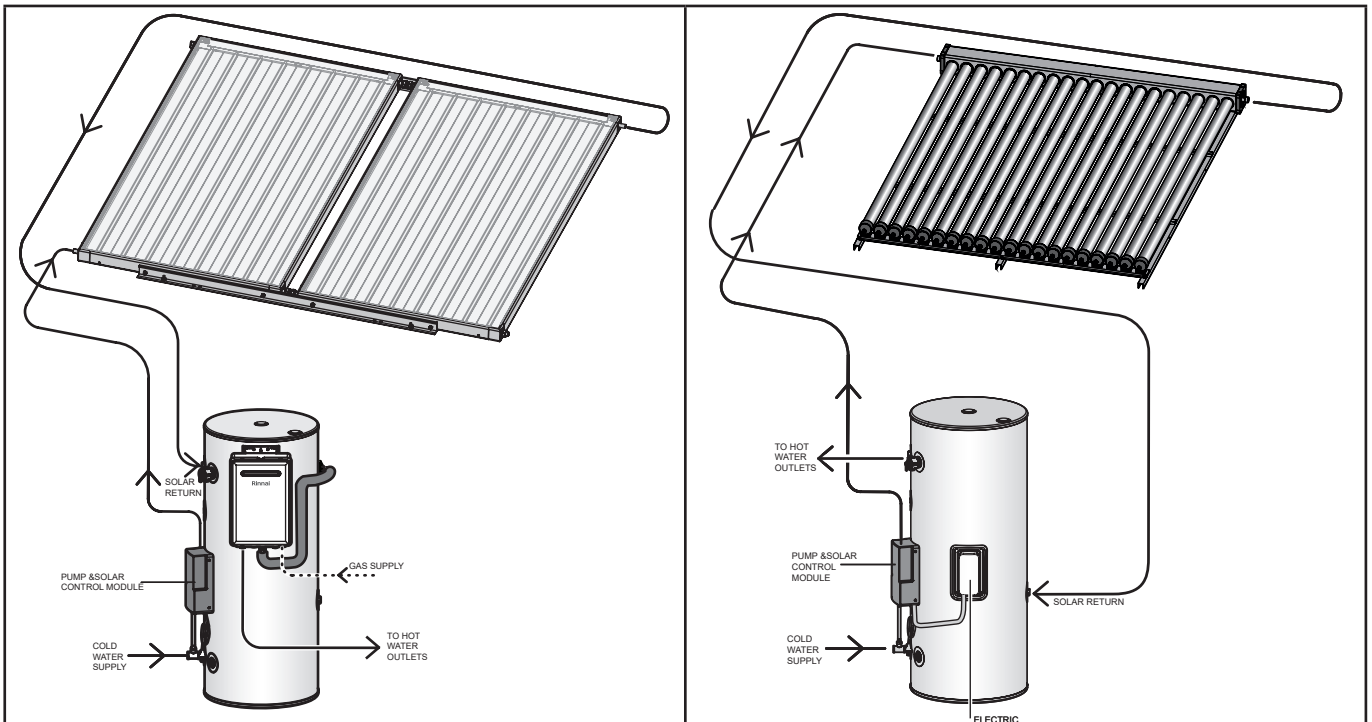

SYSTEM LOCATION

The location of all system components must comply with both local regulatory and Rinnai requirements. In particular solar collectors need to be positioned on roofs in accordance with the instructions in the solar collector installation manual, that is provided with the collector installation kit.

SAFETY DEVICES

The water heating system is supplied with various safety devices including temperature sensors, overheat sensors and switches and a Pressure & Temperature Relief (PTR) valve. These devices must not be tampered with or removed. The water heating system must not be operated unless each of these devices is fitted and is in working order.



DO NOT tamper with or remove safety devices.

DO NOT operate the water heater unless all safety devices are fitted and in working order.

DO NOT block or seal the PTR Valve and drain pipe.

Pressure & Temperature Relief (PTR) Valve

This valve is located near the top of the water heater and is essential for safe operation. It is normal for the valve to release a small quantity of water through the drain line during heating.

However, continuous leakage of water from the valve and its drain line may indicate a problem with the water heater.

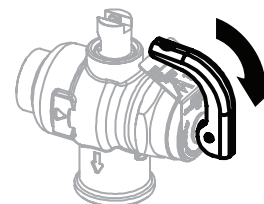

Lift lever until water flows from drain line (Lower lever gently!)



Never block the outlet of the PTR valve or its drain line for any reason. The easing gear must be operated at least every 6 months to remove lime deposits and verify that it is not blocked. Failure to do this may result in the water heater failing.

If the valve does not discharge water when the easing gear lever is opened, or does not seal again when the easing gear is closed, attendance by an authorised person must be arranged without delay. The PTR valve is not serviceable.

EXCESSIVE DISCHARGE FROM SAFETY DEVICES

Pressure & Temperature Relief (PTR) Valve

It is normal and desirable that this valve allows a small quantity of water to be discharged during the heating cycle. If it discharges more than approximately 5 litres of water during a 24 hour period or discharges continuously there may be another problem.

If the valve dribbles continuously, try easing the valve gear for a few seconds as described above. This may dislodge any foreign matter and alleviate the problem.

If the valve discharges at high flows, especially at night, it may be as a result of the water pressure exceeding the design pressure of the water heater. Ask your installer to fit a Pressure Limiting Valve (PLV).



NEVER replace the PTR valve with one which has a higher pressure rating than is specified for your water heater.

Expansion Control Valve (ECV) - if required

It is normal that this valve allows a small quantity of water to be discharged during the heating cycle. If it discharges more than a bucket of water during a 24 hour period or discharges continuously there may be another problem.

If the valve leaks continuously, try easing the valve gear for a few seconds. This may dislodge any foreign matter and alleviate the problem. If this does not alleviate the problem contact Rinnai.

Operate the easing gear regularly to remove any lime deposits and to verify that it is not blocked.

GAS BOOSTERS

Do not touch the flue outlet or do not insert any objects into the flue outlet.

- Keep flammable materials, spray cans, fuel containers, trees, shrubs and pool chemicals etc, well clear of the flue outlet.
- Do not use the gas types other than those designated on the data plate. For example, do not use Propane/ Butane gas mixtures on appliances marked Propane Gas.
- Do not use Propane Gas on appliances marked as Natural Gas and vice versa.

HYDROGEN GAS

In the case of systems using a vitreous enamel lined cylinder, if the hot water unit is not used for two weeks or more, a quantity of hydrogen gas, which is highly flammable, may accumulate in the water heater. To dissipate this safely, it is recommended that a non electrically operated hot tap be turned on for two minutes at a sink, basin, or bath, but not a dishwasher or other appliance. During this procedure there must be no smoking, open flame or any electrical appliance operating nearby. If hydrogen is discharged through the tap, it will probably make a sound like air escaping.

WATER TEMPERATURE

The solar control unit and pump ensure water circulates between the solar collectors and storage cylinder until the water at the base of the cylinder reaches approximately 65°C. Under these conditions water at the hot outlet may exceed 85°C. During periods of low solar gain supplementary heating can occur. The gas booster will heat any water from the solar tank that is less than 55°C to 70°C. Electric boosting temperatures will depend on the solar controller used. However the thermostat on the tank must be set to 60°C to meet Australian regulatory requirements.



To meet Australian regulatory requirements, supplementary heating must be operational.

**TURNING THE WATER HEATING SYSTEM OFF AND ON
Off***

If it is necessary to switch off the water heater, do so as outlined below:

**Refer to the note at the bottom of the page for important information regarding the effects of powering off the system.*

Electric Boosted Systems

- Switch off the electrical supply to the supplementary heating element. The switch is usually marked and located in the electricity meter box of the dwelling.
- Switch off the electric supply to the solar controller and pump.

Gas Boosted systems

- Switch off the electric supply to the gas booster.
- Switch off the electric supply to the solar controller and pump.



Turning off power to the solar controller will prevent operation of the pumped water circulation used in Pumped Frost Protection mode. This may be required for warranty on the solar collectors. Refer to the supplied warranty booklet.

On

Electric Boosted system

- Switch on the electric supply to the supplementary heating element(s). The switch is usually marked and located in the electricity meter box of the dwelling.
- Switch on the electrical supply to the solar controller pump.
- Electric and solar water heating will now occur as required. It may take a number of hours before hot water is available.

Gas Boosted systems

- Switch on the electrical supply to the gas booster.
- Switch on the electrical supply to the solar controller and pump. Solar water heating will now occur.
- Hot water is available immediately from the gas booster when hot water tap is opened, irrespective of solar heat gain.

WATER QUALITY

The water quality of most public supplies is suitable for the water heating system. The water quality from bore wells is generally unsuitable for the water heating system. Refer to the warranty booklet for water quality parameters and how they affect the warranty conditions. If in doubt about the water quality, have it checked against the parameters listed in the warranty conditions. The system is not suitable as a pool or spa heater.

Draining and Filling the Water Heating System

Draining or filling normally occur only during installation or servicing and must be carried out by an authorised person.

MAINTENANCE AND REGULAR CARE

Operate the easing gear of the PTR as described in the section 'Safety Devices' on page 8.

The overflow tray (supplied by installer) and drain underneath the storage cylinder (if fitted) should be periodically checked to ensure there are no blockages.

SERVICING AND REPAIR

Our Servicing network personnel are fully trained and equipped to give the best service on your appliance. If your appliance needs service, ring the service contact numbers on the back of this booklet.

It is recommended that the system be serviced at least every 3 years.

The pressure and temperature relief valve and expansion control valve must be checked for performance or replaced by an authorised person at intervals not exceeding 5 years or more frequently in areas where the water is classified as scaling water (refer to the supplied warranty booklet).

It is recommended that the sacrificial anode fitted to vitreous enamel lined cylinders be inspected every 5 years or more frequently in areas where there is a high incidence of water deposits. This does not apply to stainless steel cylinders. Anodes suited to hard and soft water, are available from Rinnai.

If the electric conduit, power supply cord or plug to the water heater is damaged, they must be replaced by an authorised person in order to avoid a hazard.

SAVE A SERVICE CALL

Before contacting Rinnai for service, please follow the fault finding guide. If the problem persists or this information doesn't answer your questions, contact Rinnai on the phone number on the back of this manual

Service call outs attending to any condition or fault that is not related to Rinnai product or components may be chargeable.

INSUFFICIENT OR NO HOT WATER	
Excessive hot water consumption	<p>Electric Boosted Systems:</p> <p>Often people are surprised at the amount of hot water used, especially when showering. If the amount of hot water used during the day exceeds the storage capacity of the cylinder, it is likely that there will be insufficient hot water.</p>
	<p>Gas Boosted Systems:</p> <p>Insufficient flow may occur if multiple outlets are in use at the same time and exceed the rated flow capacity of the gas booster. If so, reduce the number of outlets in use.</p> <p>Consider discussing with your installer, fitting water saving fixtures and/or flow control or pressure limiting valves to reduce consumption.</p>
Incorrect solar system size	The system may not have been adequately sized to suit the household.
Temperature and pressure relief valve / expansion control valve discharging water continuously	<p>PTR Valves & ECV Valves (if fitted)</p> <p>It is normal and desirable that this valve allows a small quantity of water to be discharged during the heating cycle. If it discharges more than approximately 5 litres of water during a 24 hour period or discharges continuously there may be another problem.</p> <p>If water continuously dribbles from the valve, try easing the valve gear for a few seconds as described in the section 'Maintenance and Regular Care' on page 10. This may dislodge any foreign matter and alleviate the problem.</p> <p>If the valve discharges at high flows, contact your installer or Rinnai to discuss.</p>
Booster heating not operating or insufficient gas supply for gas boosted heating system	<p>Electric Boosted Systems:</p> <p>Check to ensure the electric isolating switch(es) at the switchboard (usually marked "hot water" or "water heater") is switched 'ON'.</p> <p>Check to ensure that the electric fuses for hot water at the switchboard are intact.</p> <p>On systems using a deluxe controller, ensure the time is set correctly and that the mid tank sensor (white lead) is in place. (See controller manual for information about electric element operation.</p>
	<p>Gas Boosted Systems:</p> <p>Check to ensure the power cord of the gas booster is plugged in and switched 'on'.</p> <p>Check gas is available and the isolation valve is opened.</p> <p>Close the hot tap and wait for 10 seconds and open it again. The hot tap must be opened enough to ensure that the flow rate is sufficient to light the gas booster.</p> <p>Check if there is gas supply to other appliances in the rest of the house.</p>
Booster thermostat settings	<p>Electric Boosted Systems:</p> <p>Check the temperature of hot water delivered with a thermometer placed under the closest outlet (usually the kitchen sink) on a non-tempered hot water line.</p> <p>This test should be done early in the morning after overnight electrical boosting before any hot water is used. The temperature of the water delivered should be at least 55°C (allowing for heat losses in pipe work).</p> <p>If this is not the case, the temperature may need to be increased. Contact your installer or Rinnai to discuss adjusting the thermostat.</p>

HIGH ELECTRICITY OR GAS BILL	
<p>Hot water usage patterns</p>	<p>Electric Boosted Systems - Standard Solar Controller:</p> <p>If using an off peak (overnight) boosted electrical system with a Standard Solar Controller, the time of use of the water may affect whether heating is done by electric element or solar energy. This is because both solar heated water and electrically heated water are stored in the same cylinder. (This is not a problem with gas boosted systems, and is less of an issue with mid element storage cylinders as the electric element only heat the top half of the tank, leaving half the tank for solar energy).</p> <p>If the bulk of hot water is used in the morning, there will be cold water in the cylinder for the sun to heat during the day leading to lower electricity usage.</p> <p>If the bulk of the hot water is used in the evening, the electric element will reheat the water overnight. In the morning there will be no cold water in the storage cylinder for the sun to heat.</p> <p>Consider changing your usage pattern to optimise solar energy usage.</p> <p>Electric Boosted Systems - Deluxe Solar Controller:</p> <p>If using the Deluxe Solar Controller, the time of use of the water may affect whether heating is done by electric element or solar energy. This is because both solar heated water and electrically heated water are stored in the same cylinder.</p> <p>If insufficient hot water remains for use, the controller will turn the electric element on to heat a small quantity of water. If this occurs often, the electricity bill may be higher than expected.</p> <p>Consider changing your usage pattern to optimise solar energy usage.</p>
<p>High electricity cost</p>	<p>Electric Boosted Systems:</p> <p>The electricity tariff will determine the running costs of the system. Contact the electricity supplier to confirm what these tariffs are.</p> <p>When using a deluxe controller, a daily sterilisation boost can occur between 2 am and 6 am. Ensure that the time is correctly set on the controller and that this boosting time matches any lower price electricity tariffs.</p>
<p>Solar control unit switched off</p>	<p>If a standard solar controller is switched off there will be no solar pre-heating of water, resulting in the water being heated entirely by electricity or gas boosting.</p> <p>If a deluxe solar controller is switched off, there will be no solar preheating and no electric boosting.</p> <p>Check the power outlet for the solar control unit is switched on</p>
<p>Mid Sensor not in place (Deluxe Controller only)</p>	<p>If the mid sensor is not installed properly, it may be detecting a lower than the actual temperature and turning the element on more than required.</p> <p>See controller manual for more details.</p>
<p>Temperature and pressure relief valve / expansion control valve discharging water continuously</p>	<p>See entry under 'Insufficient or No Hot Water'</p>
<p>Lack of solar gain</p>	<p>Reduced sunlight due to overcast weather in summer or low solar contribution in winter will result in an increased dependence on electricity or gas boosting. Higher electricity or gas bills under these conditions, especially in winter, are normal.</p> <p>If the solar collectors are shaded by trees or other objects, or the glass is dirty, the effectiveness of the collectors is greatly reduced. Arrange for trimming of trees or relocation of the solar collectors if the obstruction is permanent. Arrange for cleaning of the collector glass</p> <p>Solar collectors incorrectly positioned will also severely affect the solar gain. Check that positioning and alignment of solar collectors is in accordance with the section 'System Orientation and Inclination' in the solar collector installation manual.</p>

NO WATER FROM THE HOT TAP	
Restriction in the hot tap or failure of the cold water supply to the heater	Check for water flow at the other hot taps and that the cold water isolation valve is fully open.
BROKEN OR DAMAGED EVACUATED TUBE COLLECTORS	
Broken or Damaged Flat Plate Collectors	<p>If any of the evacuated tubes have a clear or white bottom this may indicate that the vacuum in the glass tube has gone, and the tube will not be performing properly. The tubes are normally a silver colour.</p> <p>If the vacuum in the tubes is gone or the tube is obviously broken, the system can still be used. The remaining tubes will be fully operational. However the system performance will be reduced.</p> <p>If a tube is broken or damaged it should be replaced. Contact Rinnai to discuss.</p>
CONDENSATION IN COLLECTORS	
Condensation in flat plate solar collectors	There is a small amount of ventilation between atmosphere and the internals of the solar collector to ensure efficient operation. Under certain weather conditions, water vapour naturally present in the air may condense on the inside surface of the collector glass. This does not affect the performance of the system. If you are concerned contact Rinnai to discuss.
NOISY SOLAR COLLECTORS	
Noise from solar collectors	<p>Occasionally on days of high solar gain, the water temperature in the collector may become very high. The noise may be similar to a boiling kettle, or an expanding contracting metallic sound. The collector is designed to withstand these conditions, and no action is needed, unless it is extreme. Contact Rinnai to discuss if you have any concerns.</p> <p>Noise can also occur due to low water supply pressures, especially systems installed on tanks. In such cases the pressure setting on the pump may need adjustment. Contact Rinnai to discuss any concerns.</p>
SOLAR PUMP CONTINUOUSLY OPERATING	
Temperature sensor leads not in place	The system will not operate correctly if the temperature sensor leads are not correctly positioned (dry well on storage cylinder and on the solar collector outlet). Contact your installer or Rinnai to discuss.
WATER HAMMER	
Hot and cold water plumbing in the premises	Contact your installer or a plumber to discuss checking the clipping of hot and cold water pipe work and install a pressure limiting valve or water hammer arrestor as required
WATER COMING FROM COLLECTORS ON ROOF	
Frost valve(s) operating (flat plate collectors)	In conditions where the water in the solar collector could freeze and damage the collector, the frost valve(s) will release a small quantity of water to prevent the build up of pressure.

SPECIFICATIONS

SYSTEM

Specifications for the various components are shown below.

System Type	Glass Lined Cylinders SG175, SG175A, SG215A, SG270A, SG320A, SE250AB, SE250AM SE315AB, SE315AM	All Stainless Steel Cylinders 160,250,315
Solar flow and return connection:	Rp ¾	Rp ¾
PTR valve connection:	Rp ½	Rp ¾
Cold inlet connection:	Rp ¾	Rp ¾
Hot outlet connection:	Rp ¾	Rp ¾
PTR valve setting	1000 kPa	850 kPa
Rating of PTR Valve supplied	10 kW	10 kW
Expansion Control Valve (ECV) setting	850 kPa	700 kPa
Max supply pressure with ECV	680 kPa	550 kPa
Max supply pressure without ECV	800 kPa	700 kPa
Pressure limiting valve rating (supplied by installer if required)	500 kPa	500 kPa

Flow Control

A variable speed pump controls the water flow rate through the collectors and storage cylinder to optimise the performance of the system.

Solar Controller

There are two types of Rinnai solar controller available for residential solar hot water systems:

- The Standard Controller is used with all gas boosted systems and electric boosted systems with an independently controlled element. It should not be used with an electric tank with a mid sensor port.
- The Deluxe controller is used for systems with an electric element tank that has a mid sensor port.

Both controllers operate of the pump to optimize solar energy collection and stop energy collection when the cylinder is full of hot water. They both also have the option of Pumped Frost Protection.

The Deluxe controller has the additional functionality of controlling the operation of the electric element for tank sterilisation and for optimal performance.

For full details see the solar controller manual.

SOLAR COLLECTORS

Full specifications for the solar collectors can be found in the installation manual provided in the collector installation kit. The following information is provided to assist in completing the installation

	ENDURO & EXCELSIOR	ENDURO XL	Evacuated Tubes
Potential Solar Output at PTR relief conditions	1.25 kW	1.40 kW	20 tubes - 1.30 kW 25 tubes - 1.63 kW 30 tubes - 1.96 kW
Frost Protection	FOR MORE INFORMATION ON FROST PROTECTION REFER TO WARRANTY BOOKLET		Power must be on at the pump and the solar controller must be in Pumped Frost Protection Mode. See the solar controller manual for more details. FOR MORE INFORMATION ON FROST PROTECTION REFER TO WARRANTY BOOKLET

STORAGE CYLINDERS
Glass Lined Gas Boosted Cylinders

	SG175	SG175A	SG215A	SG270A	SG320A
Cylinder height	1530	1610	1575	1470	1760
Gas booster flue outlet	1400	1485	1455	1345	1645
Solar Return and PTR	1310	1435	1380	1250	1540
Gas supply and hot water out	940	995	960	855	1150
Flow line to collectors	665	665	690	715	715
Cold water inlet	225	160	185	210	210
Cylinder diameter	515	500	540	610	641
System depth	710	700	740	810	810
Weight empty (kg)	66	66	88	91	107

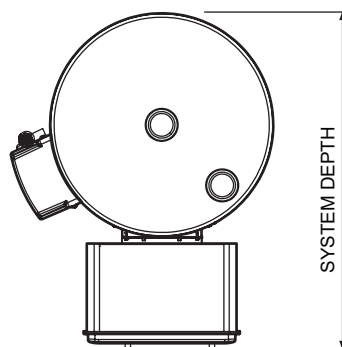
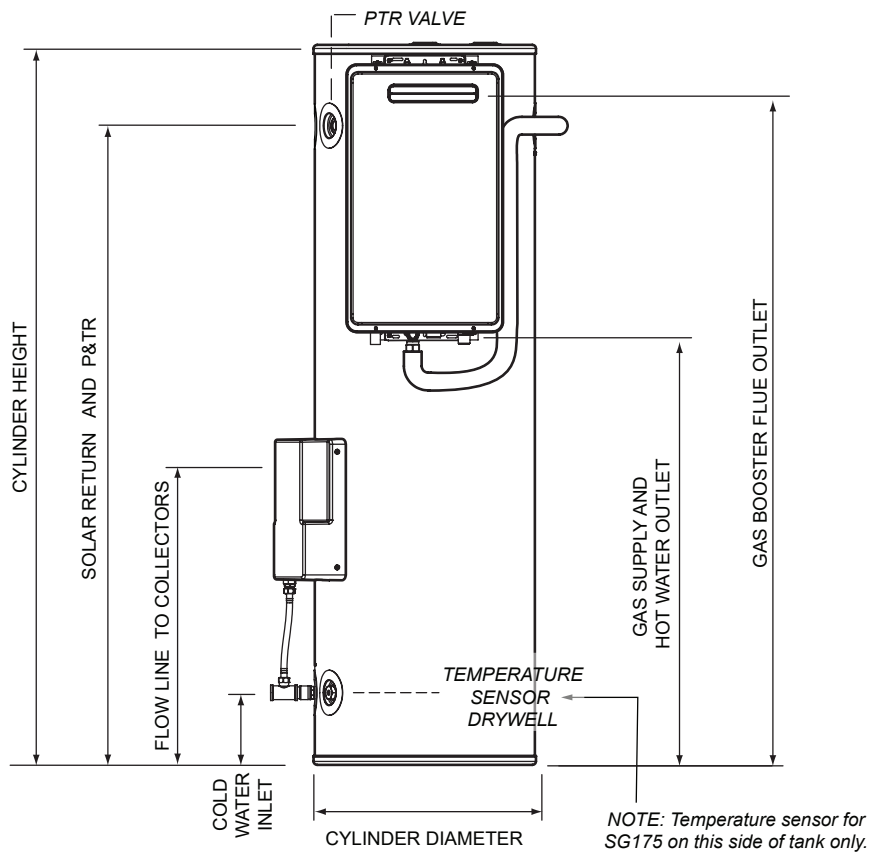

SPECIFICATIONS

Glass Lined Electric Boosted Cylinders

	SE200AB	SE250AB & SE250AM	SE315AB & SE315AM
Cylinder height	1575	1470	1760
PTR / hot water outlet	1375	1250	1540
Flow line to collectors	690	715	715
Solar return	550	515	620
Cold water inlet	185	210	210
Cylinder diameter	540	610	610
System depth	575	645	645
Weight empty (kg)	90	93	109

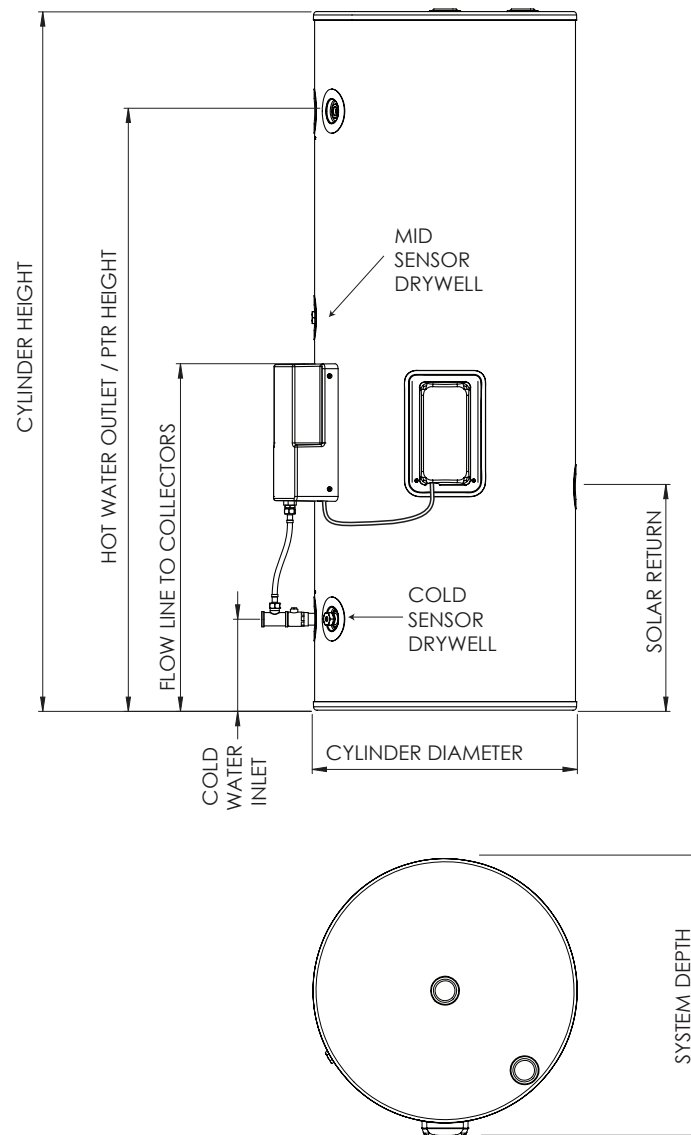

Stainless Steel Gas Boosted Cylinders

	250	315
Cylinder height	1700	2090
PTR / hot water to booster	1490	1880
Gas booster flue outlet	1345	1735
Gas supply and hot water outlet	880	1270
Flow line to collectors	650	650
Solar return	300	300
Cold water inlet	210	210
Cylinder diameter	600	600
System depth	795	795
Weight empty (kg)	56	68

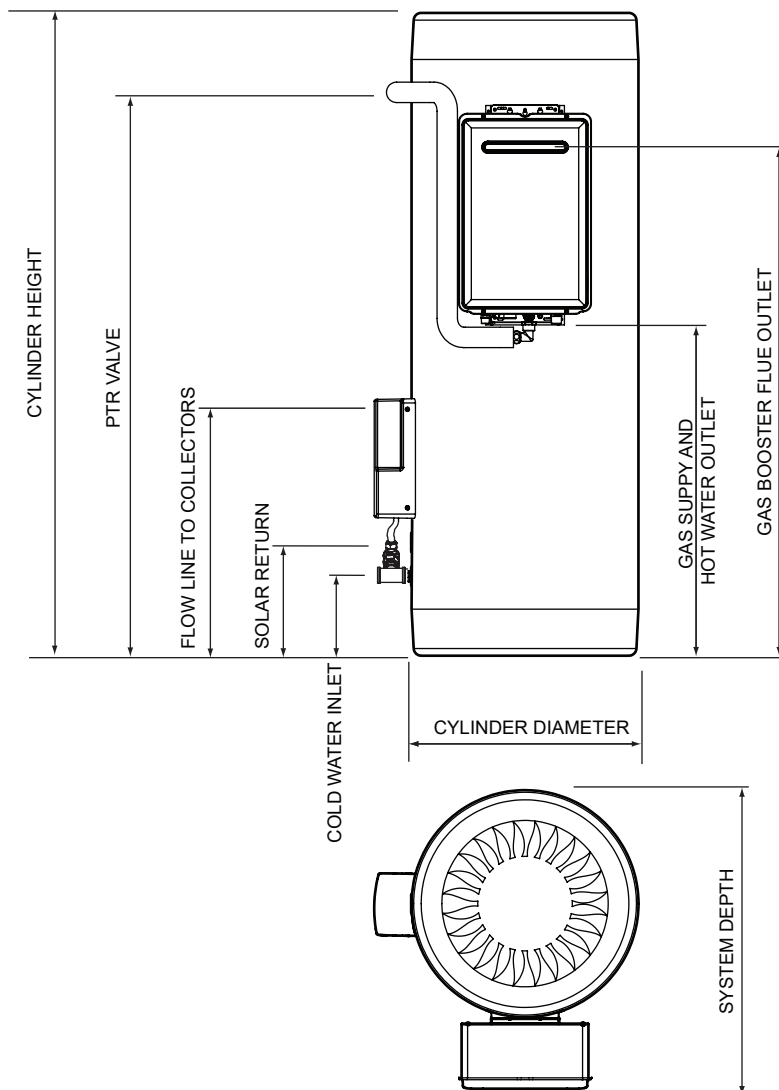

SPECIFICATIONS

Stainless Steel Electric Boosted Cylinders

	160	250	315
Cylinder height	1205	1700	2090
PTR / hot outlet	995	1490	1880
Flow line to collectors	650	650	650
Solar return	300	300	300
Cold water inlet	210	210	210
Cylinder diameter	600	600	600
System depth	635	635	635
Weight empty (kg)	46	56	68

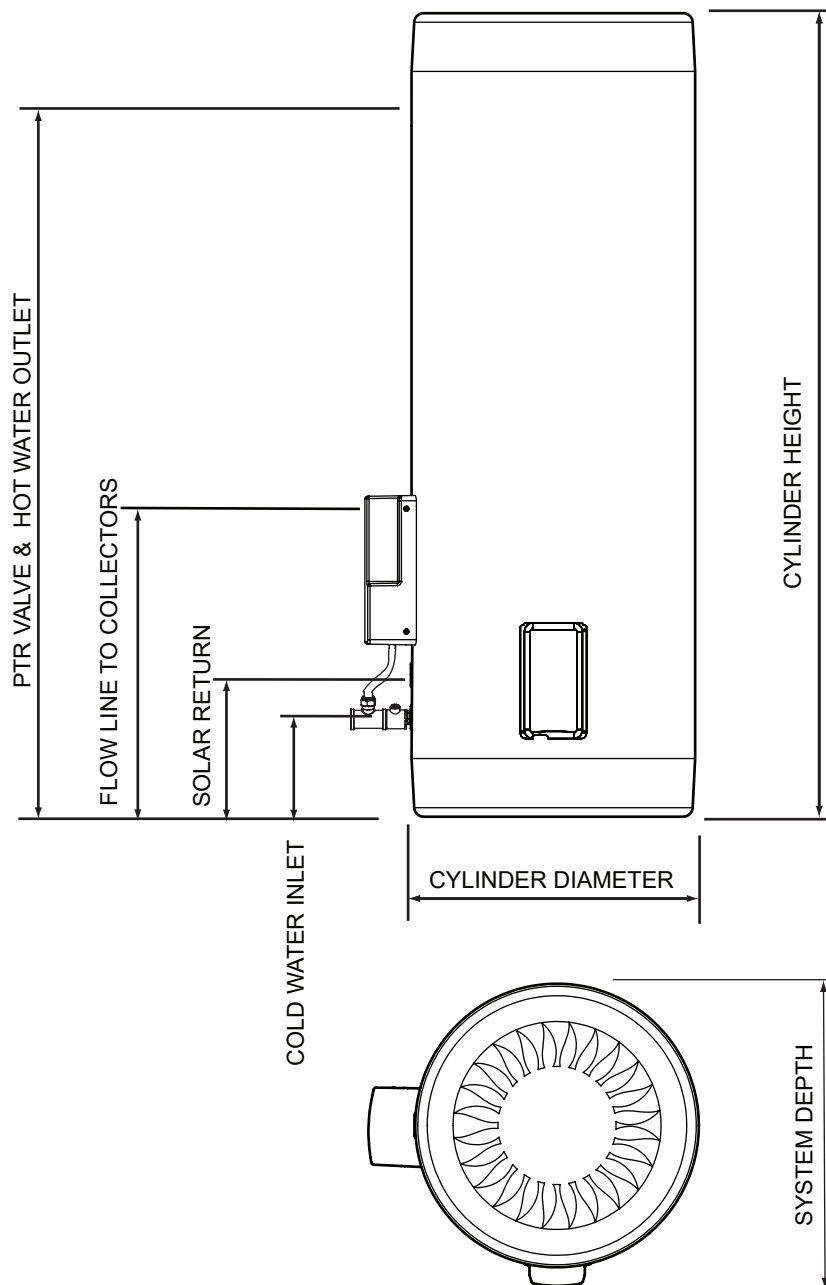

GAS BOOSTERS

Model Name	S20	S26	S28i *	S32 *
Boost capacity at 20°C rise (l/min)	20	26	37	37
Boost capacity at 25°C rise (l/min)	16	26	28	32
Maximum rated flow (l/min)	20	26	37	37
Minimum water supply pressure for maximum rated flow (kPa) ¹	120	200	140	180
Frost protection	Yes			
Gas consumption maximum (MJ/h)	124	199	210	250
Gas consumption minimum (MJ/h)	16	16	11	21
Hot water delivery temperature (°C) ²	55-70			
Dimensions - height x width x depth (mm)	530 x 350 x 195		583 x 357 x 245	600 x 470 x 244
Weight (kg)	13	15	21	29

1 Units will operate at lower pressures but the rated flow will not be achieved.

2 Gas boosters for Solar hot water applications will be set by Rinnai to deliver a minimum temperature of 70°C when the incoming water temperature is below 55°C. When the incoming water temperature is above 55°C due to solar heating, the burners of the gas booster will not operate.

Solar Gas boosters will be marked as Solar.

Units not marked 'Solar' MUST NOT be used.

* These models are made to order.

Due to ongoing product improvement the specifications of the gas booster may vary.

Refer to the documentation supplied with the gas booster for up to date specifications.



Gas Boosters other than models designated "S20", "S26", "S28i", "S32" or "Solar" must not be used. Gas Boosters marked with the text: "THIS APPLIANCE DELIVERS WATER NOT EXCEEDING 50°C IN ACCORDANCE WITH AS 3498" are incompatible with solar hot water systems and must not be used.

INSTALLATION

REGULATIONS AND OCCUPATION HEALTH AND SAFETY (OH&S)



Installation and commissioning must only be performed by authorised persons.

Solar systems must be installed in accordance with these instructions and all regulatory requirements which exist in your area including those in relation to manual lifting, working at heights and on roofs. Applicable publications and regulations may include:

- AS/NZS 5601 Gas Installations
- AS/NZS 3500 National Plumbing and Drainage
- AS/NZS 3000 Wiring rules
- Plumbing Code of Australia (PCA)
- Building Codes of Australia (BCA)
- Local Occupational Health and Safety (OH&S) regulations

This appliance is not suitable for use as a domestic spa pool or swimming pool heater.

Solar collectors are heavy and bulky items and are usually positioned on the roofs of buildings. Australian State and Territories have a principal Occupational Health and Safety (OH&S) Act which contains requirements relating to the handling of large, bulky or awkward items and the prevention of falls from elevated surfaces. Persons installing solar collectors must be aware of their responsibilities and be adequately trained and qualified, in accordance with local OH&S requirements.

LOCATION

General Information

All system components must be in an accessible location. The storage cylinder must be accessible without the use of a ladder or scaffold. Sufficient clearances shall allow access to, and removal of, all serviceable parts. Ensure the PTR valve, pump kit, drain lines and thermostat and elements for electric systems have sufficient clearances and are accessible for service and removal. The information on any data plates must also be readable. In the case of vitreous enamel lined cylinders, leave a clearance of the height of one storage cylinder above the cylinder being installed so the sacrificial anode can be inspected and replaced. This does not apply to stainless steel cylinders.

Select suitable areas of roof on which to install the solar collectors as close as practicable to the cylinder. Ensure that the area is even and without cracked or damaged tiles. Collectors should be positioned for optimum solar benefit, and to minimise wind loading. Refer to the installation manual supplied with the collector installation kit for more information.

The solar pump kit and gas booster heater require an AC 240V power supply. A weatherproof 240V, 10A earthed power point must therefore be provided adjacent to these.

All electrically boosted solar hot water heating elements must be connected to an independent, fused, AC 240V 50 Hz power supply with an isolating switch installed at the switch board.

Storage Cylinder

The storage cylinder should be placed as close as practicable to the most frequently used hot water outlet point or points to minimise the delay time for hot water delivery. This will usually be the kitchen tap.

The solar storage cylinders have an ingress protection rating of IPX4 making them suitable for internal or external installation.

Storage cylinders must be installed in free-standing mode on a level and stable base. For external installations, storage cylinders should be mounted on a concrete base at least 50mm thick or on well seasoned, evenly spread hardwood slats with a thickness of at least 25mm. Where property damage can occur, storage cylinders should be installed with an approved safe tray (overflow tray).

Ensure the cylinder does not stand on wet surfaces.

Gas Booster

Unless specifically designated as a internal model, the gas booster is designed for outdoor installation only. As such, it must be located in an above ground open air situation with natural ventilation, without stagnant areas, where gas leakage and products of combustion are rapidly dispersed by wind and natural convection. The location must comply with the clearances specified in AS/NZS 5601. See page 26.

The gas booster must be mounted on a vertical structure with the water and gas connections on the underside pointing downwards. In most installations the gas booster is mounted directly on the storage cylinder using two custom made mounting brackets (supplied). In all cases the heated outlet of the cylinder is connected to cold water inlet of the gas booster.

GAS SUPPLY

The maximum gas consumption of the gas booster and the required gas pressure are shown on the appliance data plate. If the gas pipe sizing is insufficient the customer will not get the full performance benefit. Gas pipe sizing must consider the gas input to the gas booster as well as all the other gas appliances on the premises. The gas meter and regulator must be specified for this gas rate. An approved sizing chart such as the one in AS/NZS 5601 should be used. An approved full flow isolation valve and disconnection union must be fitted to the gas supply inlet of the gas booster. Isolation valves must not be fitted directly to the booster.

ELECTRIC SUPPLY



Electrical connection must only be carried out by a qualified person and in accordance with AS/NZS 3000 'Wiring Rules' and local authority requirements.

For electrically boosted systems with the standard controller, the electrically boosted solar hot water heating elements must be connected to an independent, fused, AC 240V 50 Hz power supply with an isolating switch installed at the switch board. Ensure the household wiring to the system is capable of withstanding the system electrical load (refer to specifications for electrical load details). Twin element models are factory wired for 'non simultaneous' operation.

For electrically boosted systems with the deluxe controller, the connection box within the solar controller must be connected to an independent, fused, AC 240V, 15A, 50 Hz power supply with an isolating switch installed at the switch board. Ensure the household wiring to the system is capable of withstanding the system electrical load (refer to specifications and the controller manual for electrical load details).

The solar pump kit requires an AC 240V power supply from a 10A earthed power point adjacent to the storage cylinder. For outdoor installations this power point must be weatherproof. This power supply is only used for operating the controller and the pump. It must be independent from the power supply to any heating elements.

HOT WATER TEMPERATURE

Gas Boosted Systems

Gas boosters for use in solar hot water systems are preset to deliver a temperature of 70°C when the incoming water temperature is below 55°C, and not to heat when the incoming water temperature is above 55°C, in accordance with plumbing regulations. In addition, they contain the warning stating "Rinnai Water Controllers are NOT compatible with solar hot water installations and MUST NOT BE USED in the vicinity of the temperature controller connections inside the appliance."

Electric Boosted Systems

To comply with Australian Standards the storage cylinder thermostat set point must be at least 60°C.

Hot Water Delivery Temperature

Local regulations and/or the requirements of AS/NZS 3500.4 must be considered regarding the temperature limitations of hot water supplied to areas used primarily for personal hygiene. The temperature of water to these areas is limited to 45°C for early childhood centres, primary and secondary schools and nursing homes or similar facilities for young, aged, sick or people with disabilities and 50°C for all other buildings. To comply with these requirements, a temperature limiting device, such as a thermostatic mixing or tempering valve, will be required on all solar hot water systems.

WATER PIPES, FITTINGS AND INSULATION



The solar hot and solar cold pipes between the solar storage tank and the solar collectors must be suited to the high water temperatures and pressures that may occur. As such, plastic pipe must not be used. Components used to join pipes must use metallic materials to achieve sealing. The collector flow and return pipes should be at least 15 mm copper tube.



AS/NZS 3000 specifies the requirements for the separation of distributed gas and water piping from low voltage wiring systems. As such, the 5V DC sensor leads shall maintain a separation of not less than 25 mm from any above-ground gas or water piping, or as otherwise revised in AS/NZS 3000.

Insulation

All hot water pipework should be insulated with sealed polyethylene foamed or equivalent insulation to optimise performance and energy efficiency, and to protect against frost damage. Such insulation may also be mandatory under local regulations.

Rinnai recommend insulation to achieve at least the R value shown in the following table.

Location of Installation	Pipes on Roof Flat Plate Collectors	Pipes on Roof Evacuated Tube Collectors	Pipe between tank and gas booster
<ul style="list-style-type: none"> CER Zone 4 Areas defined as Evacuated Tube Only in the latest version of the Rinnai Solar Hot Water Warranty Booklet. Any other area prone to frost conditions. 	R = 1.0K.m ² /W	R = 1.0K.m ² /W	R = 0.6 K.m ² /W
<ul style="list-style-type: none"> All other areas 	R = 0.6 K.m ² /W	R = 1.0K.m ² /W	R = 0.6 K.m ² /W

All supplied insulation materials must be fitted as shown to minimise heat losses. In frost prone areas this insulation will also protect against frost damage.

Pipe Sizing

With the exception of solar collector flow and return pipes, water pipe sizing should be performed in accordance with AS/NZS 3500. All external pipework **MUST** be insulated to prevent frost damage.

The maximum combined lengths of the solar flow and return pipes are as follows:

Pipe Size	1 Flat Plate Collector EVT20A or EVT25A	2 Flat Plate Collectors EVT30A or 2 x EVT20A	3 Collectors
DN 15	40 metres	40 metres	30 metres
DN 20	60 metres	60 metres	40 metres

WATER SUPPLY

The maximum water pressures for the various systems are listed on page 14. Approved pressure limiting valves may be required if the maximum rated water supply pressures are exceeded. For gas boosted systems to achieve the rated flow through the outlet of the continuous flow water heater, the minimum water supply pressures must be supplied. The systems will operate at lower pressures but the rated flow will not be achieved.

Water chemistry and impurity limits are detailed in the warranty booklet. Most metropolitan water supplies fall within these requirements. If you are unsure about water quality, contact your water authority. If sludge or foreign matter is present in the water supply, a suitable filter should be incorporated in the water supply to the storage cylinder.

FROST PROTECTION MODE

Information on pumped frost protection is provided in the separate controller manual.

VALVES AND FITTINGS

The following valves and fittings are supplied with your solar hot water system:

- A combined pressure and temperature (PTR) relief valve, capacity 10 kW. Relief valve pressure settings vary with models. This valve is fitted at the top of the storage cylinder. The PTR valve is a safety device and it is mandatory that it is fitted by the installer in all installations.
- A non return valve fitted on the solar pump outlet to prevent backflow through the pump from the solar collectors. This valve is factory connected.
- Air bleed valve to assist in eliminating air from the system during commissioning.
- Fittings as shown on pages 28 to 37.

The following valves & fittings are to be supplied by the installer:

- A cold water expansion control valve (ECV). An ECV must be fitted in Western Australia and South Australia to the cold water supply to the storage cylinder to comply with local regulations. An ECV is recommended in all other geographical areas where the water supply has a tendency to cause scaling. This will reduce hot water discharge from the pressure and temperature relief (PTR) valve which minimises wear on this valve.
- A stop cock, non return valve and line strainer. Combination valves incorporating two or more of these functions (such as 'Trio' valves) are suitable. These are fitted to the cold water supply to the storage cylinder by the installer.
- Cold water supply and hot water discharge pipework to and from the storage cylinder.
- Solar collector flow and return pipes and storage cylinder connections.
- An isolating valve and connection union for the gas supply to the gas booster.
- An approved pressure limiting valve (supplied with some systems) is required if the maximum rated water supply pressure on page 14 is exceeded.
- Tempering valve(s) or thermostatic mixing valve

The diagrams on the following page show two variations of how the plumbing may be set out. All installations must comply with the requirements of AS/NZS 3500.

Typical Installation Option 1

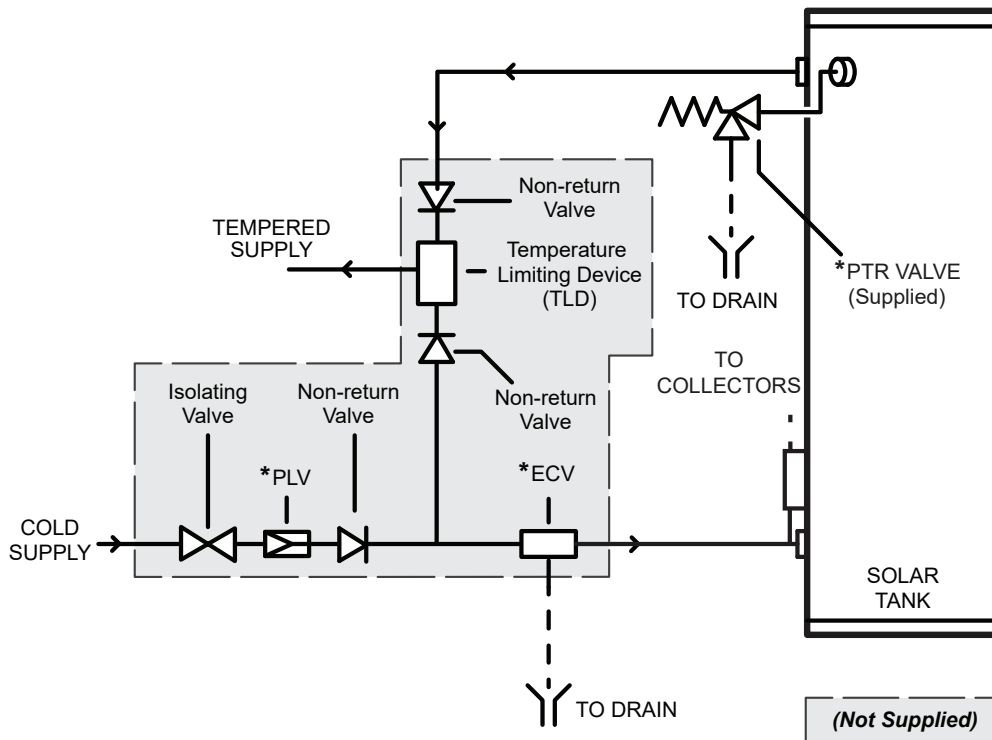

Typical Installation Option 2

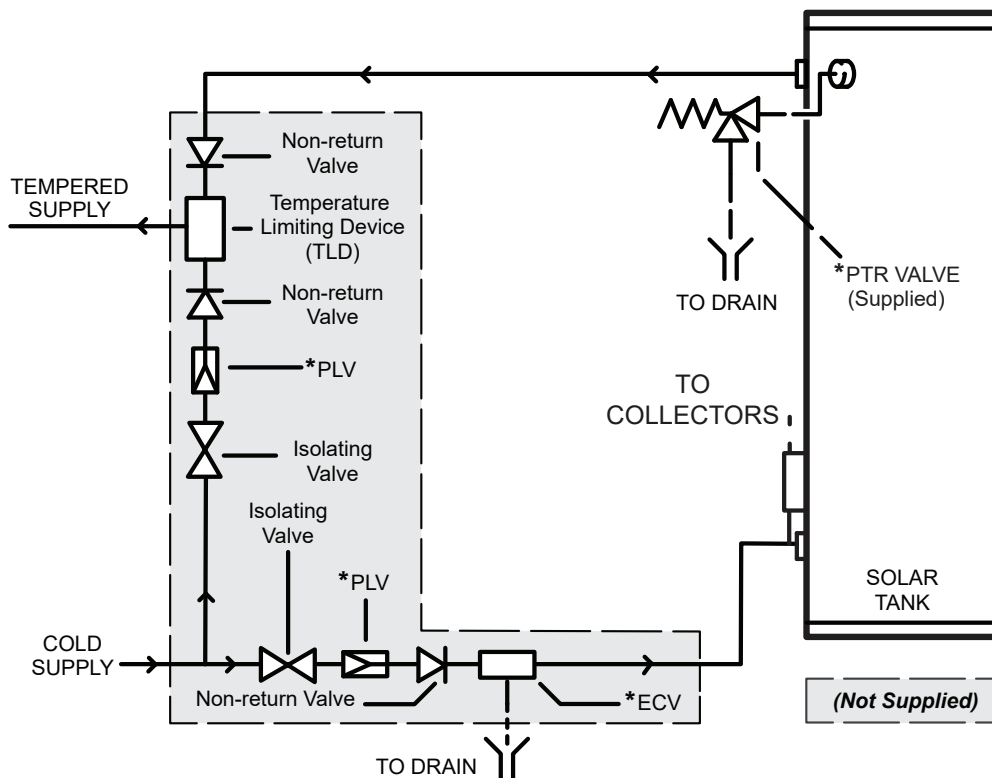

Valves with pressure ratings other than specified are unsuitable and MUST NOT be used.

*Where required. For ratings see the table on page 14.

It may be a requirement that the hot and cold water supply pressures to a Temperature Limiting Device (TLD) are equal. If this is the case, a PLV with the same pressure rating as the PLV for the hot water is required for the TLD as shown.

Gas Booster Information

Rinnai Smartstart

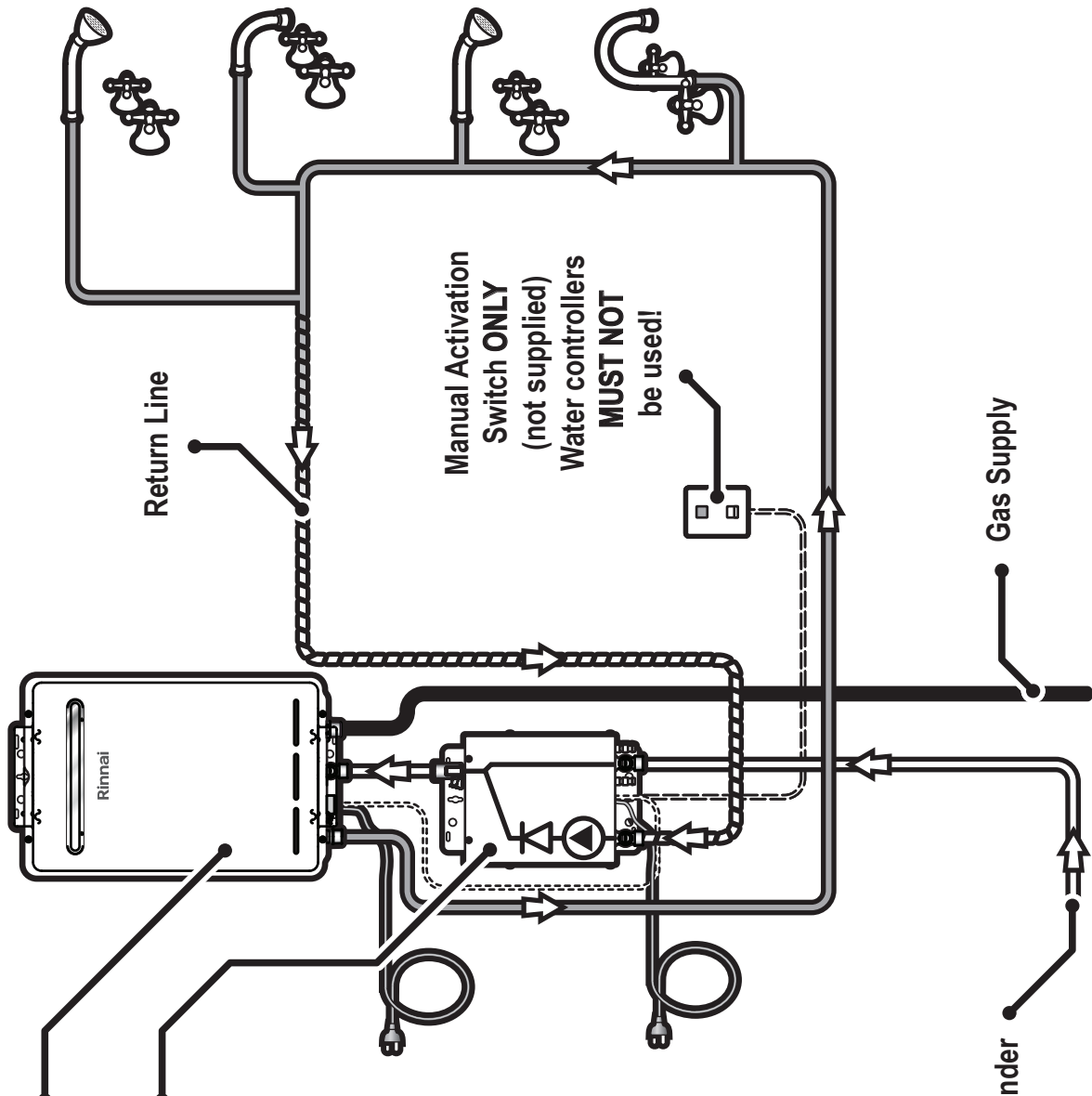

Rinnai Continuous Flow Water Heater - Gas Booster

Rinnai Smartstart Unit

! IMPORTANT

Outlets to Personal Hygiene areas to be tempered to 50°C as per AS/NZS 3500.4

Refer to Rinnai manuals supplied with appliances for important installation information.

Installations **MUST** conform to local regulations.

Gas Supply

Supply from solar storage cylinder

Manual Activation Switch **ONLY** (not supplied) **MUST NOT** be used!

Gas Booster Clearances

Figure 6.2 from AS/NZS5601 is reproduced below. It was current at the time of printing, but may have been superseded. It is the installer’s responsibility to ensure that current requirements are met.

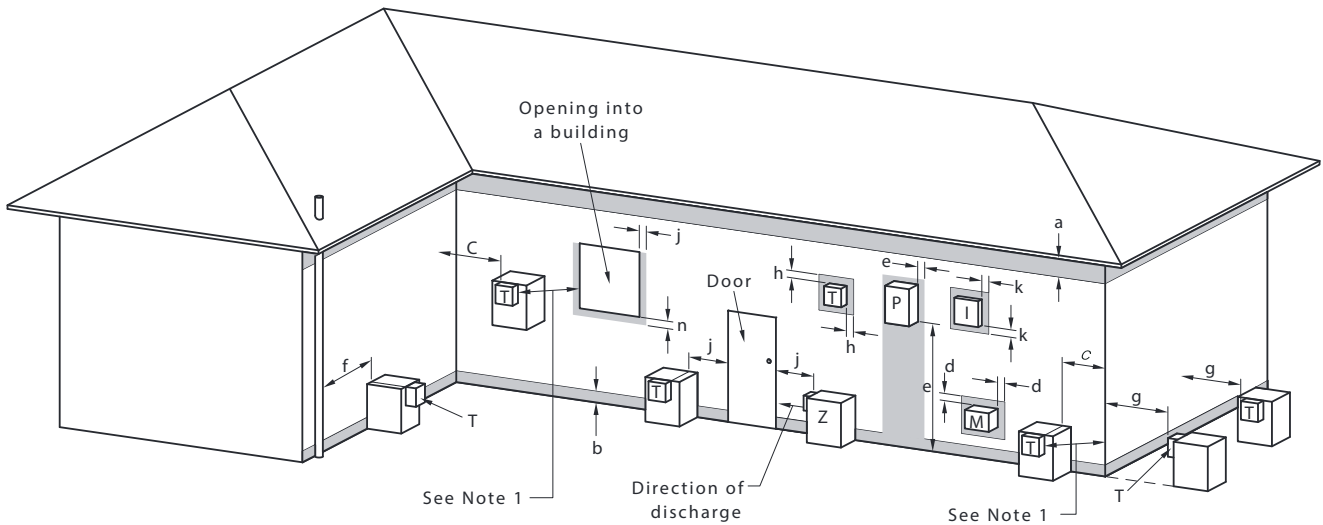

I = Mechanical air inlet M = Gas meter P = Electricity meter or fuse box T = Flue terminal Z = Fan-assisted appliance only

■ Shading indicates prohibited area for flue terminals

Ref.	Item	Min. clearances (mm)
		Fan assisted
	Below eaves, balconies and other projections:	
a	• Appliances up to 50 MJ/h input	200
	• Appliances over 50 MJ/h input	300
b	From the ground, above a balcony or other surface *	300
c	From a return wall or external corner *	300
d	From a gas meter (M) (see Note 5) (see Clauses 5.11.5.9 for vent terminal location of regulator) (See Table 6.7 for New Zealand requirements)	1000
e	From an electricity meter or fuse box (P) † (see Note 5)	500
f	From a drain pipe or soil pipe	75
g	Horizontally from any building structure* or obstruction facing a terminal	500
h	From any other flue terminal, cowl, or combustion air intake *	300
	Horizontally from an openable window, door, non-mechanical air inlet, or any other opening into a building with the exception of sub-floor ventilation:	
j	• Appliances up to 150 MJ/h input *	300
	• Appliances over 150 MJ/h input up to 200 MJ/h input *	300
	• Appliances over 200 MJ/h input up to 250 MJ/h input *	500
	• Appliances over 250 MJ/h input *	1500
	• All fan-assisted flue appliances, in the direction of discharge	1500
k	From a mechanical air inlet, including a spa blower	1000
	Vertically below an openable window, non-mechanical air inlet, or any other opening into a building with the exception of sub-floor ventilation:	
n	• Space heaters up to 50 MJ/h input	150
	• Other appliances up to 50 MJ/h input	500
	• Appliances over 50 MJ/h input and up to 150 MJ/h input	1000
	• Appliances over 150 MJ/h input	1500

* - unless appliance is certified for closer installation.

† - Prohibited area below electricity meter or fuse box extends to ground level.

NOTES:

- 1 Where dimensions c, j or k cannot be achieved an equivalent horizontal distance measured diagonally from the nearest discharge point of the terminal to the opening may be deemed by the *Technical Regulator* to comply.
- 2 See Clause 6.9.4 for restrictions on a flue terminal under a covered area.
- 3 See Figure J3 for clearances required from a flue terminal to an LP Gas cylinder. A flue terminal is considered to be a source of ignition.
- 4 For appliance s not addressed above acceptance should be obtained from the Technical Regulator.
- 5 Minimum clearances d and e also apply to any combustion air intake openings of appliances.

FIGURE 6.2 (in-part) LOCATION OF FLUE TERMINALS OF BALANCED FLUE, ROOM SEALED, FAN-ASSISTED OR OUTDOOR APPLIANCES

Gas Booster Mounting

Step 1. For stainless steel tanks, attach upper mounting bracket* using the template provided. Vitreous enamel tanks have the upper bracket pre-fitted.

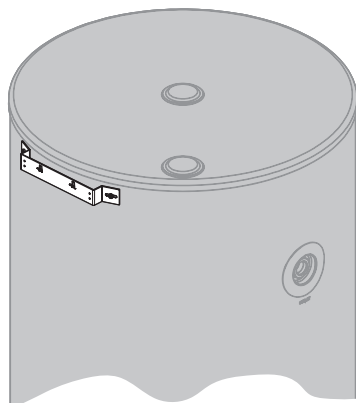

Step 2. Fix lower mounting bracket* to booster using screws provided.

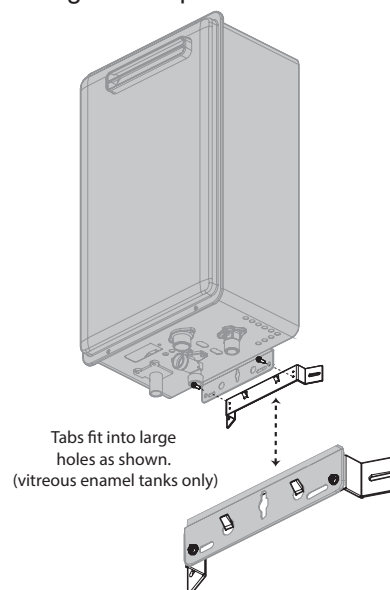

Step 3. Hang booster on bracket and secure with screws provided.

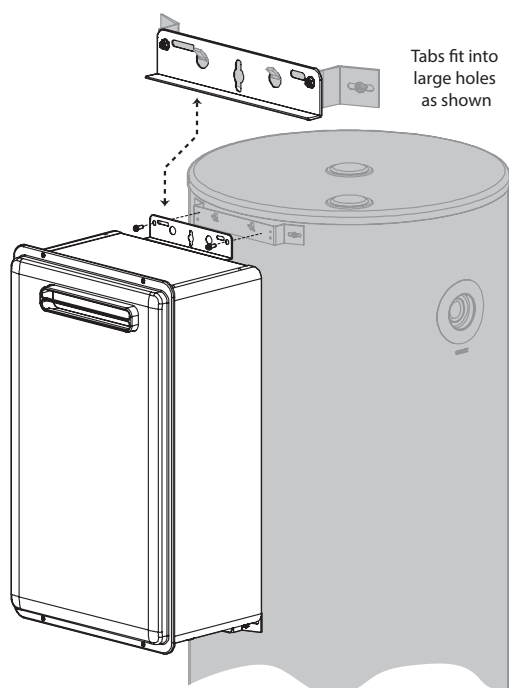

Step 4. Secure lower mounting bracket to cylinder using screws provided.

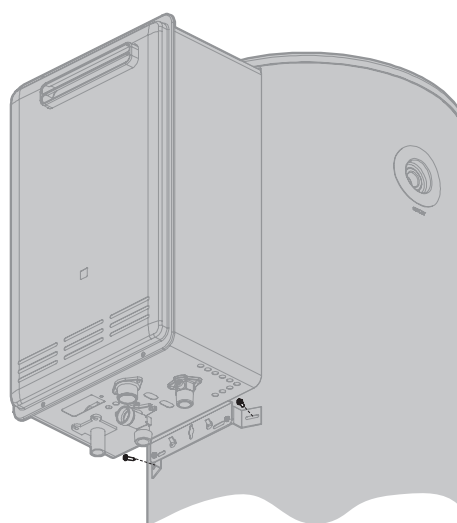

* Depending on the version of the installation kit, either one or both of the brackets may have the tabs bent out. If both of the tabs are bent out, follow instructions as shown above. If only one bracket has tabs bent out, fit it to the upper tank. The lower bracket is then mounted as shown above, without the tabs going through the holes.







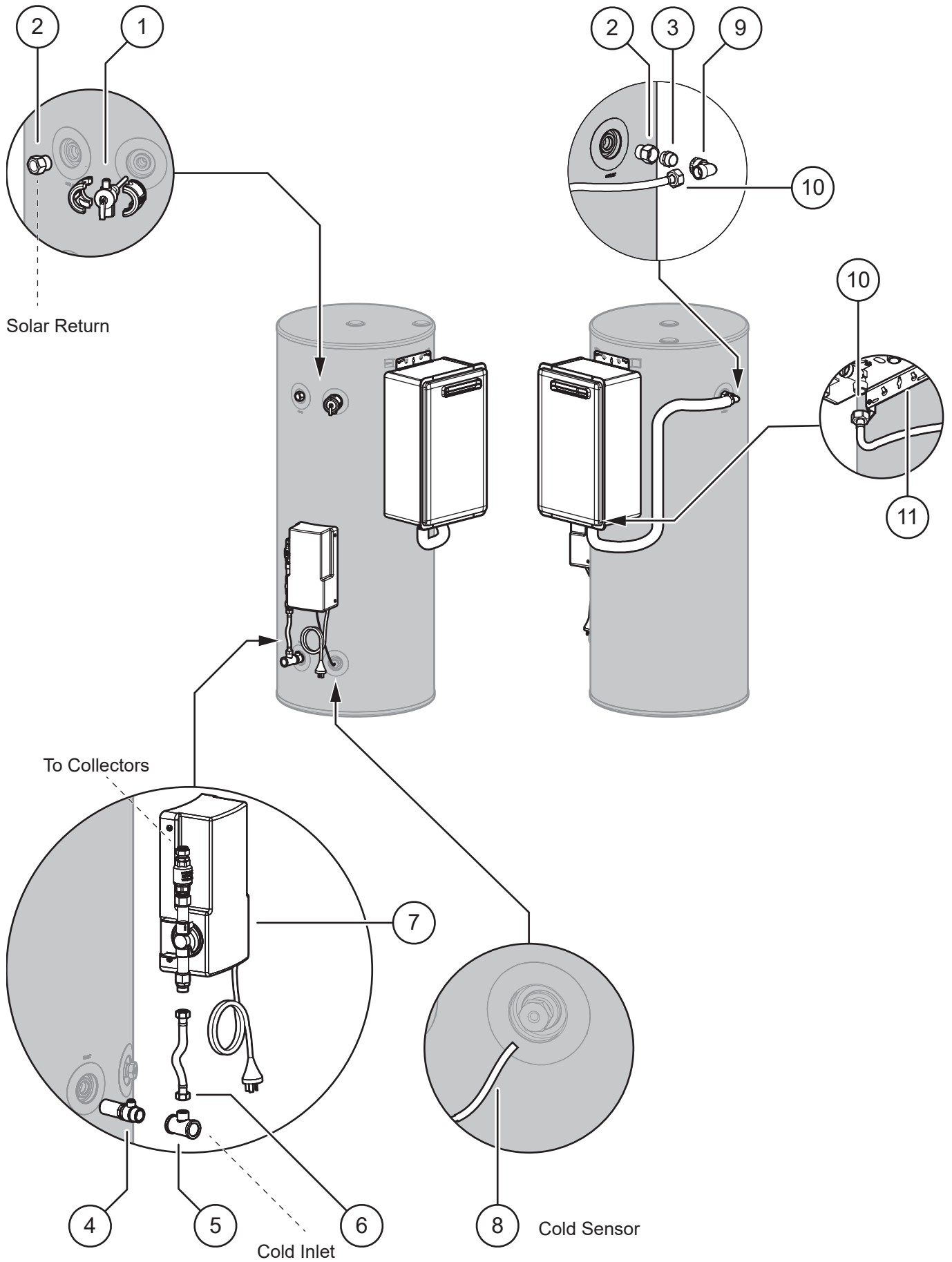



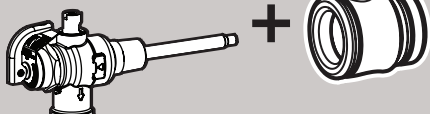

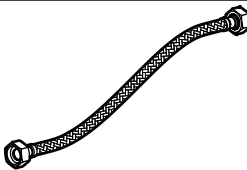
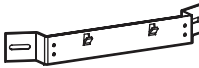
If the gas booster is not mounted on the storage cylinder, ensure that the wall or structure on which it is to be mounted is capable of supporting the weight of the appliance and associated pipe work. Refer to the table on page 19 for individual gas booster weights. For gas boosters installed on elevated structures or under floors specific requirements apply, refer to AS/NZS 5601 for details. Location of gas booster flue terminal must be in accordance with AS/NZS 5601. Refer page 26.

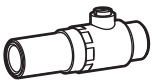
COMPONENTS AND INSTALLATION DIAGRAMS

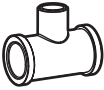
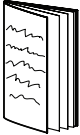
Glass Lined SG175A, SG215A, SG270A or SG320A with SGPKIT2C

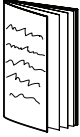
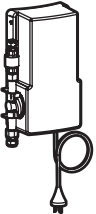







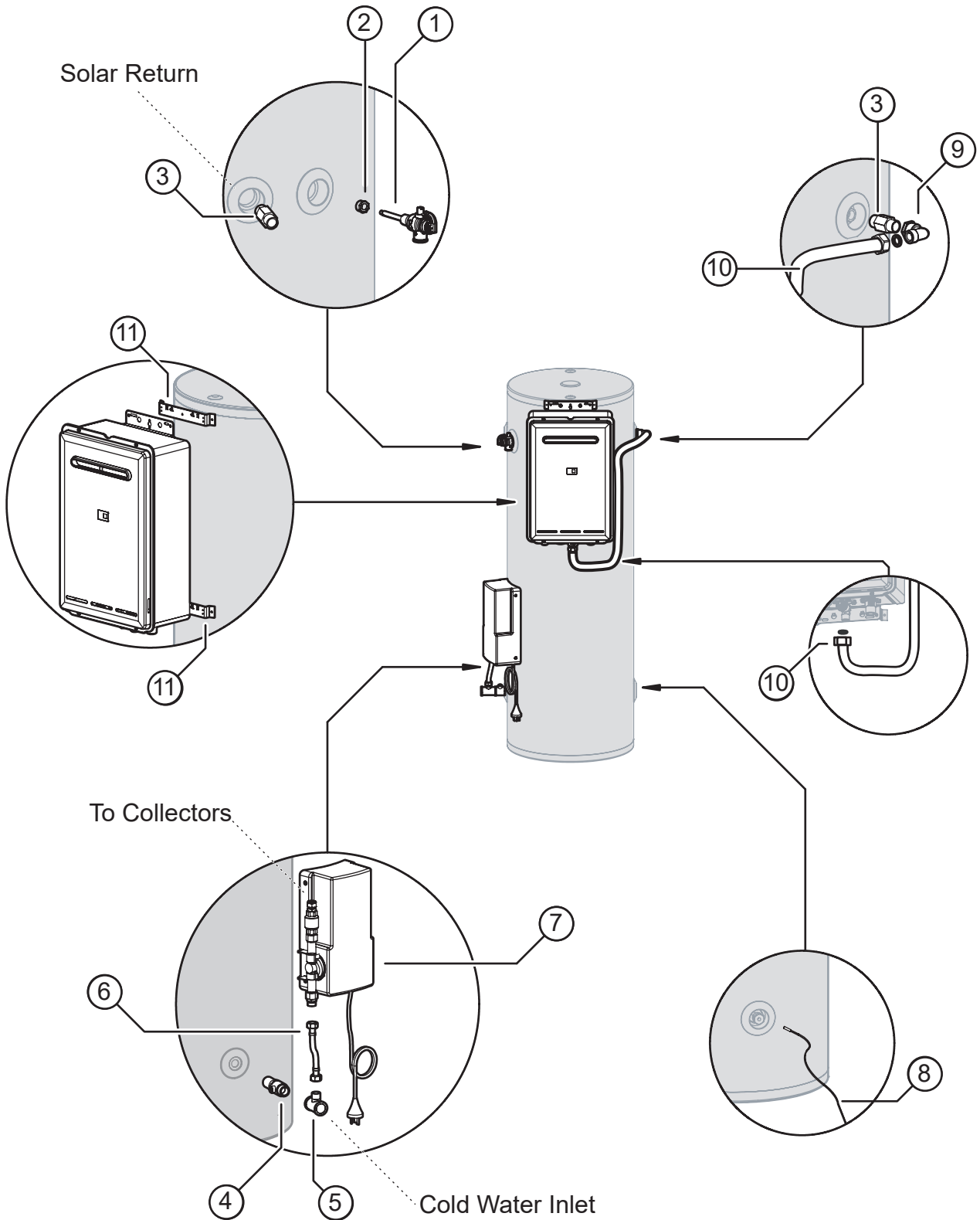

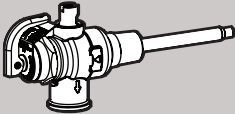

Glass Lined SG175A, SG215A, SG270A or SG320A with SGPKIT2C

Items Supplied with Cylinder				Items Supplied with KITS (cont)			
①	1		95110048	SGPKIT2C	1		21201074
②	2		95110858	⑨	1		20001020
Items Supplied with KITS				⑩	1		95110695
③	1		17201005	⑪	1		26601098 26601096
④	1		95111090	-	12		22601048
⑤	1		95111091	-	1		15401021
⑥	1		95111092	-	1		95111415
⑦	1		95111487	-	1		15401041
		Includes: • Non return valve 27801713 • Temperature sensor lead (5V DC) 31002710 • Pump 30001755 • Standard Controller 95111226		-	1		15401023
⑧	1		31002710	-	-		15401034
		Part of Pump and Controller Assembly, but shown separately for clarity in diagrams					

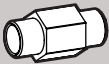
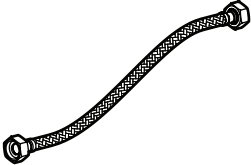
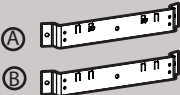
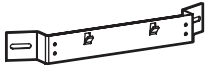
Glass Lined SG175 with SGPKIT2C

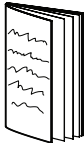
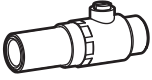
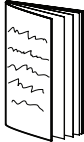

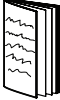
Glass Lined SG175 with SGPKIT2C

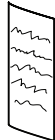
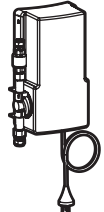
Items Supplied with Cylinder				Items Supplied with SGPKIT2C (cont)			
1	1		PTR Valve (1000 kPa) and insulation 95110048	8	1		Temperature Sensor with 2 m lead Part of Pump and Controller Assembly, but shown separately for clarity in diagrams 31002710
2	2		Adaptor R 3/4 x Rp 1/2	9	1		Elbow 3/4 Rp x 3/4 R 21201074
3	3 (1 not used)		Nipple R 3/4	10	1		Braided Flexi Pipe (inc washers) 20001020
11			Gas Booster Mounting Brackets 1 x tabs bent (A) 1 x tabs unbent (B) 26601098 26601096	-	1 (not used)		Gas Booster Mounting Bracket 95110695
Items Supplied with SGPKIT2C				-	12		Screws 22601048
-	1 (not used)		R 3/4 Nipple 17201005	-	1		Operation and Installation Manual 15401021
4	1		Valve Bleed 3/4 R 95111090	-	1		Solar Controller Manual 95111415
5	1		Tee Brass 3/4G x 1/2G 95111091	-	1		Warranty booklet 15401041
6	1		Braided Flexihose 225 mm 95111092	-	1		STC form 15401023
7	1		Standard Pump & Controller Assembly 95111487 Includes: • Non return valve 27801713 • Temperature sensor lead 31002710 • Pump 30001755 • Standard Controller 95111226	-	1		

Stainless Steel Gas Boost with USKIT1C

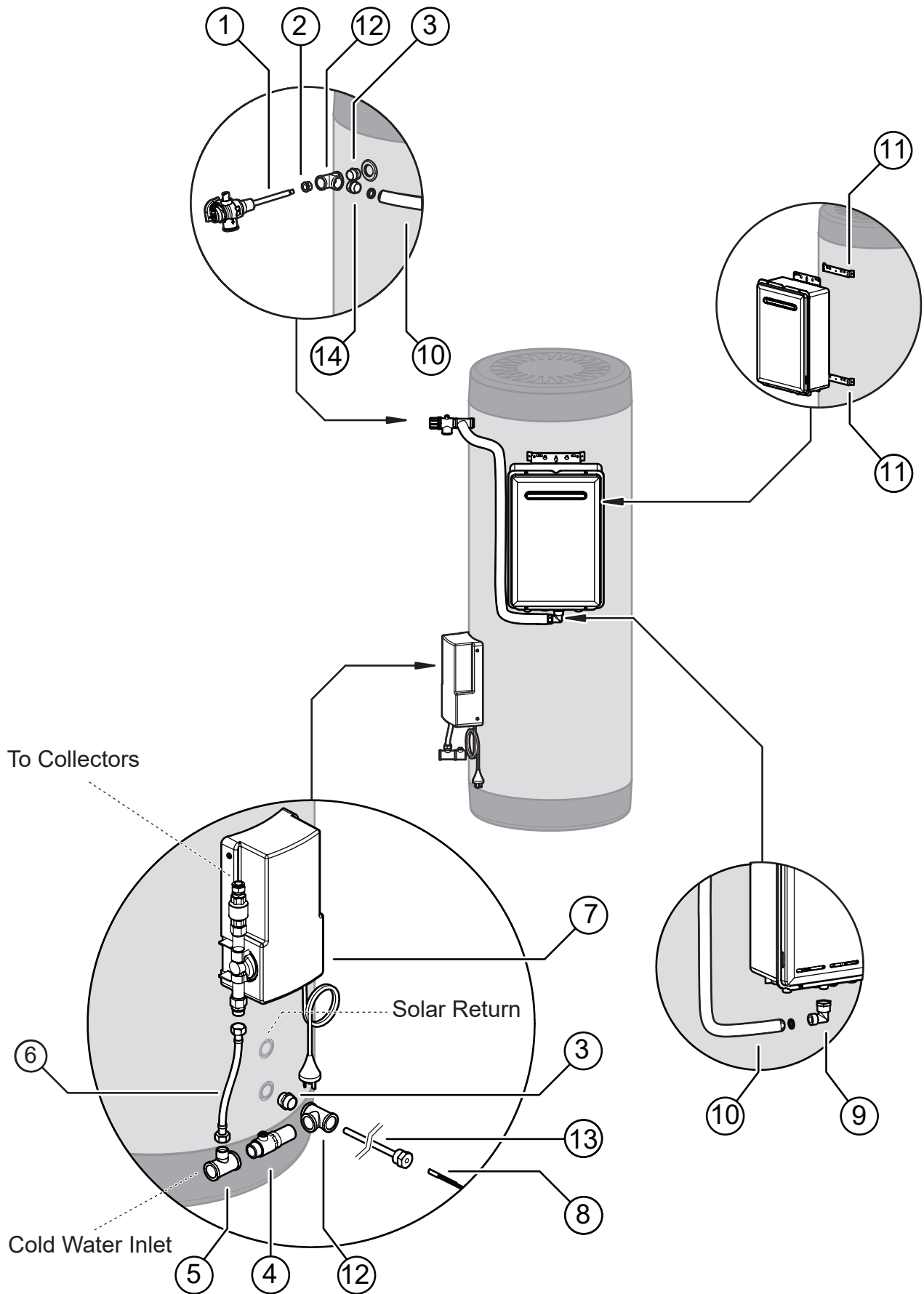







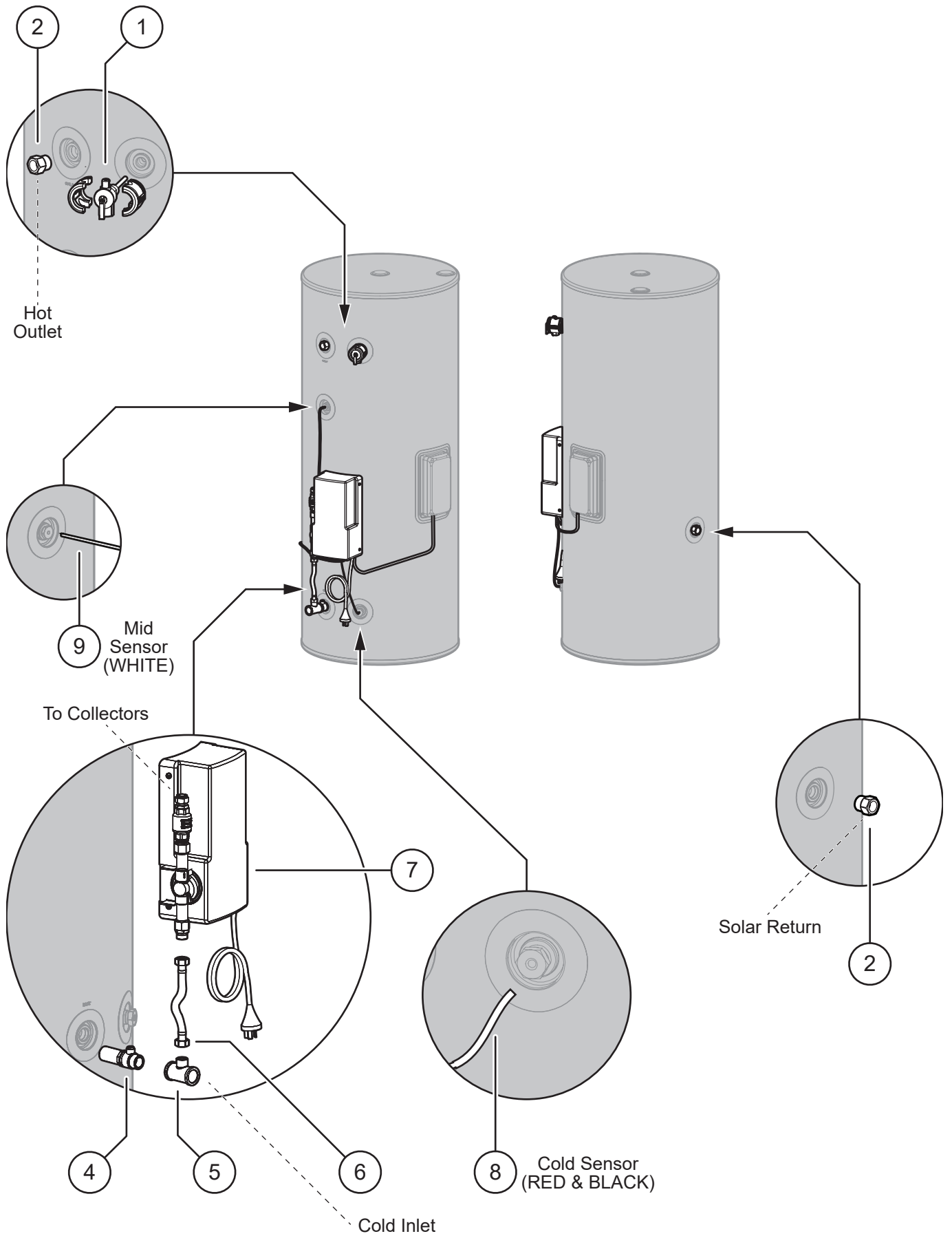

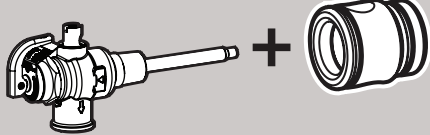

Stainless Steel Gas Boosted with USKIT1C

Items Supplied with Cylinder				Items Supplied in USKIT1C			
1	1	PTR Valve (850 kPa) 95112186	4	1	Valve Bleed 3/4 R 95111090		
2	1	Adaptor R 3/4 x Rp 1/2 19801004	5	1	Tee Brass 3/4G x 1/2G 95111091		
3	2	R3/4 Nipple 17201005	6	1	Braided Flexihose 225 mm 95111092		
9	1	Elbow 3/4 Rp x 3/4 R 21201074	7	1	Std Pump & Controller Assembly 95111487 Includes: • Non return valve 27801713 • Temperature sensor lead 31002710 • Pump 30001755 • Standard Controller 95111226		
10	1	Braided Flexi Pipe (inc washers) 20001020	8	1	Temperature Sensor (5V DC) with 2 m lead Part of Pump and Controller Assembly, but shown separately for clarity in diagrams 31002710		
11	2	Gas Booster Mounting Brackets 1 x tabs bent (A) 26601098 1 x tabs unbent (B) 26601096	-	6	Screws 22601048		
12	2	T 3/4 Rp 19001011	-	1	Operation and Installation Manual 15401021		
13	1	Temperature Sensor Sheath 250 mm 10204721	-	1	Solar Controller Manual 95111415		
14	1	Adaptor R3/4 to G3/4 (flexi) 17201006	-	1	Warranty booklet 15401041		
-	8	Screws 22601048	-	1	STC form 15401023		
-	1	Gas Booster Mounting Template 15401040					

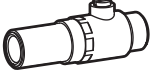
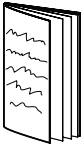
Glass Lined Electric Boosted Systems with SEPKITC

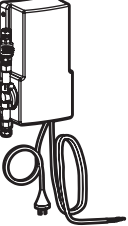
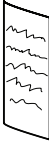

Glass Lined Electric Boosted Systems with SEPKITC

Items Supplied with Cylinder			Items Supplied in SEPKITC		
1	1	 <p>PTR Valve (1000 kPa) and insulation 95110048</p>	8	1	 <p>Cold temperature sensor (5V DC) with 2m Red & Black lead Part of Deluxe pump and controller assembly, but shown separately for clarity in diagrams 31002710</p>
2	2	 <p>Adaptor R$\frac{3}{4}$ x Rp$\frac{3}{4}$ 95110858</p>	9	1	 <p>Mid temperature sensor (5V DC) with 2 m White lead Part of Deluxe pump and controller assembly, but shown separately for clarity in diagrams 95111228</p>
Items Supplied in SEPKITC			-	1	 <p>Cable Gland 20mm For wiring to element 000851</p>
4	1	 <p>Valve Bleed $\frac{3}{4}$ R 95111090</p>	-	1	 <p>Operation and Installation Manual 15401021</p>
5	1	 <p>Tee Brass $\frac{3}{4}$G x $\frac{1}{2}$G 95111091</p>	-	1	 <p>Solar Controller Manual 95111415</p>
6	1	 <p>Braided Flexihose 225 mm 95111092</p>	-	1	 <p>Warranty booklet 15401041</p>
7	1	 <p>Deluxe Pump & Controller Assembly 95111485 Includes: <ul style="list-style-type: none"> • Non return valve 27801713 • Cold temperature sensor lead 31002710 • Mid temperature sensor lead 95111228 • Pump 30001755 • Deluxe Controller 95111227 </p>	-	1	 <p>STC form 15401023</p>
-	6	 <p>Screws 22601048</p>	-	1	

Stainless Steel Electric Boosted with USKIT1C

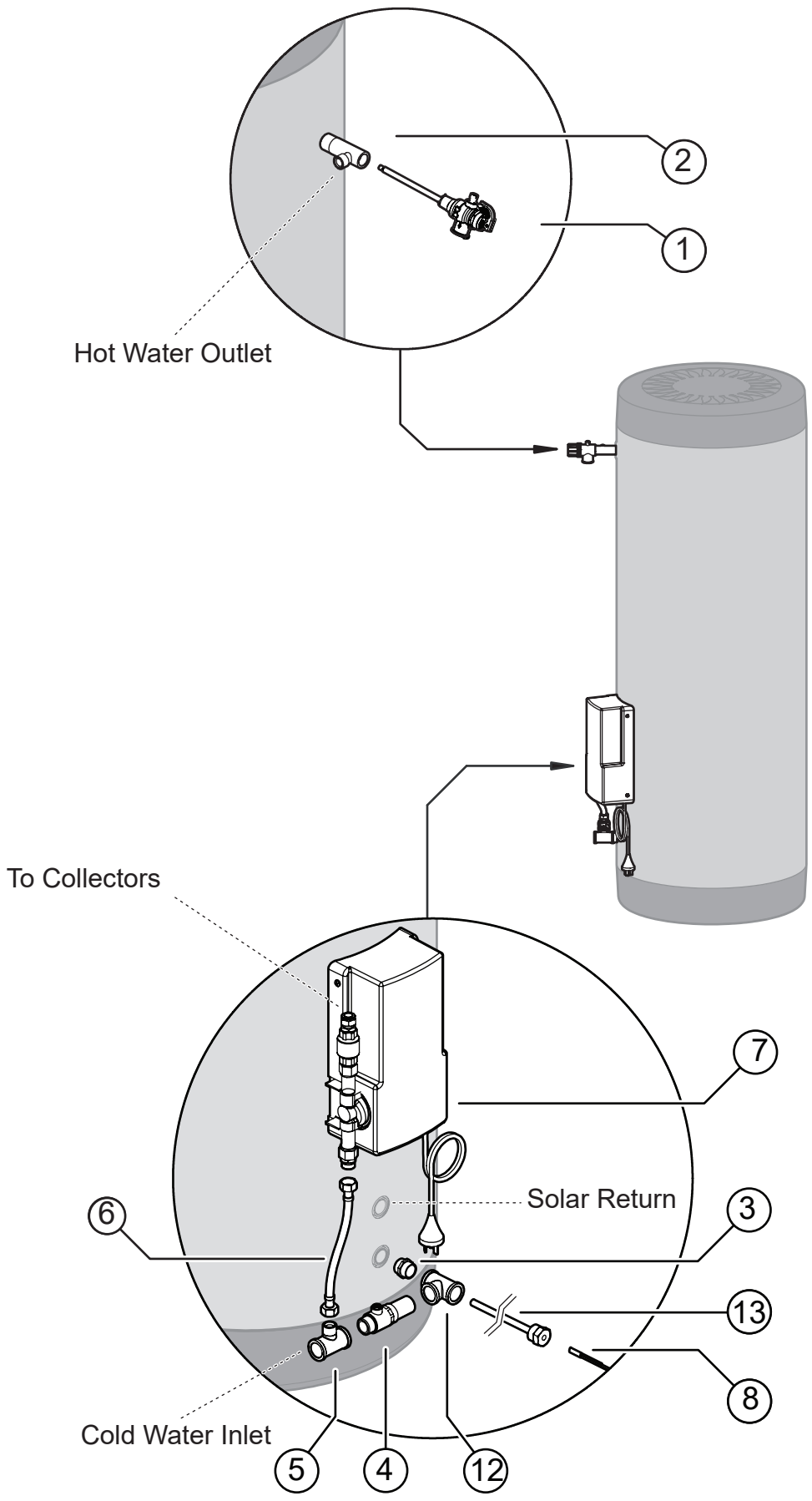

Stainless Steel Electric Boosted with USKIT1C

Items Supplied with Cylinder			Items Supplied in USKIT1C		
1	1	<p>PTR Valve (850 kPa) 95112186</p>	4	1	<p>Valve Bleed 3/4 R 95111090</p>
			5	1	<p>Tee Brass 3/4G x 1/2G 95111091</p>
2	1	<p>Hot Outlet T 19001018</p>	6	1	<p>Braided Flexihose 225 mm 95111092</p>
3	1	<p>R3/4 Nipple 17201005</p>	7	1	<p>Std Pump & Controller Assembly 95111487 Includes: <ul style="list-style-type: none"> • Non return valve 27801713 • Temperature sensor lead 31002710 • Pump 30001755 • Standard Controller 95111226 </p>
12	1	<p>T 3/4 Rp 19001011</p>	8	1	<p>Temperature Sensor with 2 m lead Part of Pump and Controller Assembly, but shown separately for clarity in diagrams 31002710</p>
13	1	<p>Temperature Sensor Sheath 250 mm 10204721</p>	-	6	<p>Screws 22601048</p>
			-	1	<p>Operation and Installation Manual 15401021</p>
			-	1	<p>Solar Controller Manual 95111415</p>
			-	1	<p>Warranty booklet 15401041</p>
			-	1	<p>STC form 15401023</p>

INSTALLATION PROCEDURE

1. Install Solar Collectors

Position and install the solar collectors in accordance with the installation manual supplied with the solar collectors.

2. Position Storage Cylinder

Position the hot water storage cylinder on a level base in accordance with the section ‘Storage Cylinder’ on page 20.

3. Connect PTR Valve

Connect the PTR Valve in the location shown in the relevant diagram on pages 28 to 37. Leave the valve outlet pointing down. Tighten the valve using the spanner flats - never use the valve body.

The PTR Valve must be adequate for the thermal loading applied to the storage cylinder. In the case of gas boosted systems the thermal load is applied only by the solar collectors. The continuous flow hot water heater does not apply thermal load to the storage cylinder. The potential solar output for the solar collectors at PTR Valve relief conditions is listed in the table on page 14.

The PTR Valve pressure ratings vary according to the cylinder specifications. The maximum heat input rating is 10.0 kW. The PTR valve rating **MUST EXCEED** the total input from the solar collectors. If it does not, the PTR valve **MUST** be exchanged for a model of higher capacity.

For example, for a gas boosted solar system with 3 x Enduro collectors, the thermal load is $3 \times 1.25 = 3.75$ kW. This is less than 10.0 kW, hence the supplied PTR valve is of sufficient capacity.

4. Mount Gas Booster (where applicable)

Mount the gas booster in accordance with “Gas Booster Mounting” on page 27

5. Connect Fittings and Mount Pump Assembly

Remove cover of pump box. Connect pump box and fittings as shown in the relevant diagram on pages 28 to 33. Position pump box on cylinder ensuring flexipipe has a smooth bend with no kinks. Attach pump box to cylinder using screws provided. **DO NOT** connect the power lead to power supply at this stage

6. Set up Solar Controller

Refer to the instructions provided in the solar controller manual.



7. Install and Connect Flow and Return Pipe Work

Connect flow and return pipe work between storage cylinder and solar collector. Ensure that suitable pipe and insulation is used as described in the section ‘Water Pipes, Fittings and Insulation’ on page 22.

A heat trap is required on the return line from the cylinder if the pipework is to rise vertically to prevent heat losses due to the thermosiphoning of hot water from the tank.

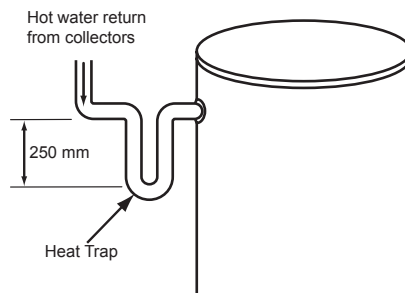

8. Connect Temperature Sensor Leads

The hot (long) temperature sensor lead should be fitted at the collector hot outlet as shown in the installation manual supplied with the solar collectors. It must be sealed in place with thermoplastic putty or silicone.

Run the lead down the solar return pipe and connect it to the connection within the pump and controller assembly as shown in the diagram. Ensure the lead is protected from light.

The cold and mid (only when using a deluxe controller) temperature sensor leads should be fitted as shown in the relevant diagram on pages 28 to 37.

Ensure the leads are protected from light. They must be sealed in place with thermoplastic putty or silicone. The plug is then connected to the pump and controller assembly as shown in the diagram.

Replace pump assembly cover.

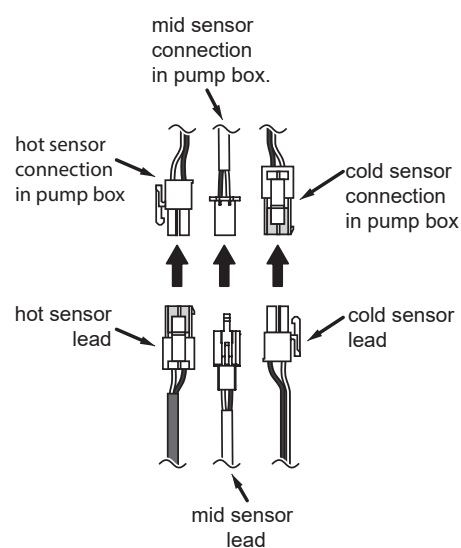

IT IS IMPORTANT THAT THESE PROBES ARE INSTALLED AS SPECIFIED. FAILURE TO DO SO WILL LEAD TO MALFUNCTION, LACK OF HOT WATER OR HIGH ELECTRICITY BILL



AS/NZS 3000 specifies the requirements for the separation of distributed gas and water piping from low voltage wiring systems. As such, the 5V DC sensor leads shall maintain a separation of not less than 25 mm from any above-ground gas or water piping, or as otherwise revised in AS/NZS 3000.

9. Cold Water Supply

Connect cold water supply to the inlet fittings as shown in the relevant diagram on pages 28 to 37. Ensure that the relevant valves are fitted as described in the section 'General Information' on page 20.

Purge the cold water supply lines to remove air and swarf before final connection.

10. Relief Drain Lines

Independent 15 mm copper pipes must be fitted to the drain outlets of the PTR and ECV. Each pipe must be open to atmosphere and run with a continual downward grade in a frost free environment to a visible discharge point. Drain lines shall comply with AS/NZS3500.4.

Valves or other restrictions must not be placed in the relief valve drain outlet line.



Some water will drip from the drain lines during heating of the water in the storage cylinder. It is recommended to discharge directly above a drain.

11. Hot Water Discharge

Connect the hot water outlet of the gas booster to the pipe work supplying hot water to the premises.



A temperature limiting device may be required as detailed in the section 'Hot Water Delivery Temperature' on page 21.

12. Connect Gas to Booster where applicable)

Connect a suitable gas supply and isolating valve to the gas booster. Follow instructions supplied with gas booster. Keep gas booster isolated at this stage.

FILLING THE SYSTEM



Ensure building occupants are warned to stay clear of the solar system components, building perimeter and roof since hot water or steam may be discharged from pipes or components.

1. Ensure the electric power supplies to the water heater and pump kit are switched OFF.
2. Ensure the gas supply to the continuous flow water heater is isolated.
3. Using a large screwdriver close the air bleed valve to divert the cold water through the collectors.

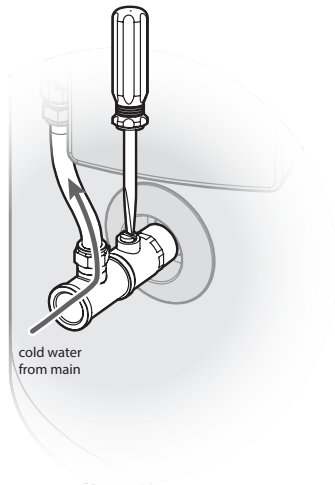

Bleed Valve Closed

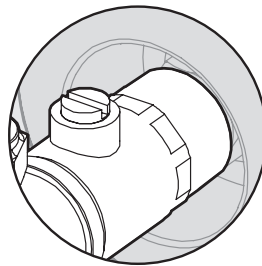

4. Turn on the hot water tap at the sink. Open the stop cock in the cold water mains supply line.
5. The entire system should fill with cold water. The air should be dispelled through the hot tap.
6. Once the tank is completely full of water, open the air bleed valve to direct the cold water from the mains back to the tank.

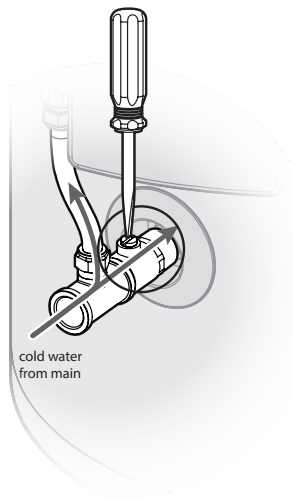

Bleed Valve Open

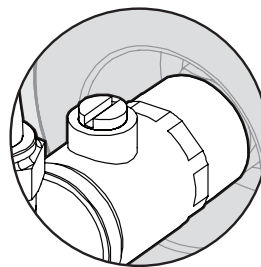

7. Turn off the hot tap at the sink when water flows freely without air bubbles or air bursts. Check all connections for leakage and tighten if necessary. This applies especially to fittings in positions not easily accessed such as near the solar collectors.
8. Operate the easing gear of both the PTR and ECV valves at the storage cylinder to ensure these valves are functional.



If leaks are detected the system must be drained and leaks repaired before the system is refilled. If this is necessary, cover the solar collectors with packaging cardboard or a tarp to prevent them from heating which could result in steam or hot water being discharged from fittings..

SOLAR PUMP OPERATION

1. Ensure all sensors are connected as shown on page 39.
2. Activate power supply.
3. Pumps will operate when solar energy is available to be collected.

Adjusting Flow Rate



If there is not solar energy available, the system can still be commissioned using the pump test function as detailed in the solar controller instructions.

The purpose of controlling the water flow rate between the collectors and storage cylinder is to optimise the performance of the system. The optimum flow rate for the system depends on the number and type of collectors.

Combined Flow and Return Pipe Length	1 flat plate collector or 20 Evacuated Tubes	25 or 30 Evacuated Tubes	40 or 50 Evacuated Tubes	2 flat plate collectors	3 flat plate collectors
< 30 metres of (DN15)					
30-40 metres of (DN15)					

PRE SOLAR HEATING CHECKS

Before commencing solar heating of the water in the system ensure the following actions have been completed:

Solar Collectors

1. Are the solar collectors installed with the correct slope and orientation to the sun?
2. Is the installation finished neatly with the roof made good, all tiles and flashings in place?
3. Are the bolts tight on the roof framework?
4. Are all solar collector straps fitted and correctly anchored to the roof structure?
5. If leak testing completed and successful, have any covers been removed from the solar collectors?
6. Has operation of the solar pump been checked?
7. Have the hot and cold sensors and leads been positioned and connected correctly?
8. Has the air bleed valve been opened?

Gas Booster (where applicable)

1. Ensure the gas supply is isolated. Remove the test point screw located on the gas inlet connection and attach a pressure gauge.
2. Turn on the electrical power to the gas booster only (not the solar pump kit) and turn on the gas supply.
3. Ensure the cold water inlet ('trio') valve on the storage cylinder inlet is open. Open all available hot water taps
4. Operate ALL other gas appliances at their maximum gas rate, in accordance with manufacturers instructions.



Ensure building occupants do not have access to hot water outlets during this procedure.

With all gas appliances in operation at the maximum gas rate, the pressure should read between 1.13 - 3.0 kPa on Natural Gas. On LPG the pressure should be 2.75 - 3.0 kPa. If the pressure is lower, the gas supply is inadequate and the appliance will not operate to specification. It is the installers responsibility to check the gas meter, service regulator and pipe work for correct operation/ sizing & rectify as required. Note that the gas regulator on the appliance is electronically controlled and factory pre-set. Under normal circumstances it DOES NOT need adjustment during installation. Make adjustments only if the gas booster is not operating correctly and all other possible causes for incorrect operation have been eliminated. Instructions for gas pressure setting are located in the pocket behind the front cover of the gas booster.

5. Close the hot water taps including the shower.
6. Close the cold water inlet ('trio') valve on the storage cylinder inlet and inspect and clean the strainer. Repeat for the strainer connected at the inlet of the gas booster. This procedure may need to be repeated to ensure the strainers remains clear, especially on new installations.
7. Confirm the hot water delivery temperature from the gas booster. This is done by checking the hot water delivery temperature at an untempered outlet close to the water heater. This is usually the hot water outlet in the kitchen. The untempered hot water delivery should be between 55°C & 70°C.

CONNECT TO ELECTRICAL SUPPLY

Standard Controller



The Standard Controller is used with all gas boosted systems and electric boosted systems with tanks that do not have a mid sensor port.

Twin element storage cylinders are wired for non simultaneous operation. The electric supply should be 'Off-Peak' (overnight) to the bottom heating unit and continuous to the top heating unit.

The power supply to a single lower element model should be Off-Peak (overnight).

The power supply to the element of mid element solar storage cylinder can be Off-Peak (overnight), extended Off-Peak (overnight and day) or continuous or other tariffs available from the local electricity supply authority.

Rinnai strongly recommends the use of an Off-Peak tariff to ensure that solar heating takes priority over electrical heating. If this isn't available, then a timer can be used to limit electrical heating to non solar hours.

Wiring Diagrams

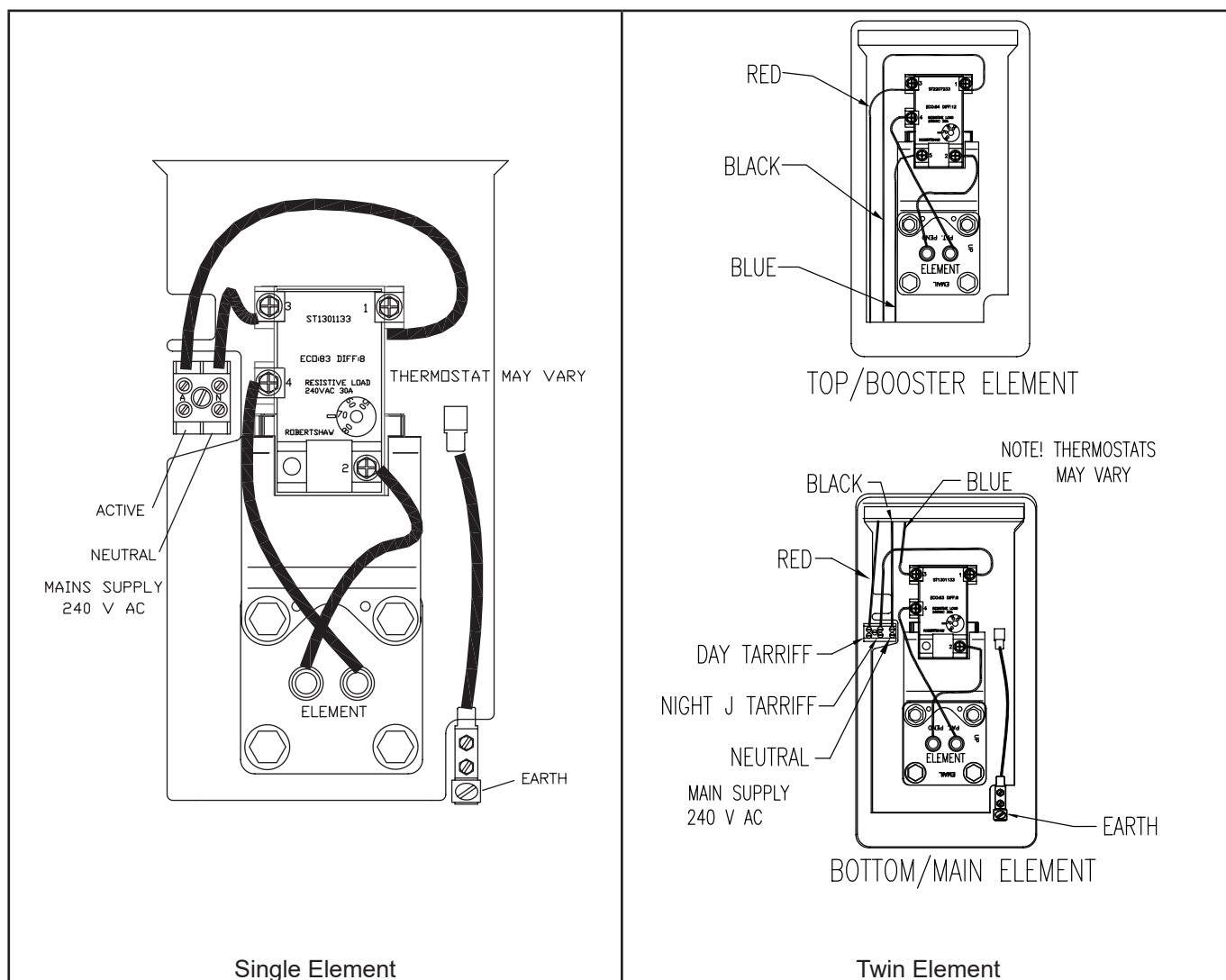

A flexible 20 mm conduit is required for the electrical cable to the storage cylinder. The conduit is to be connected to the unit with a 20mm terminator. Connect the power supply wires directly to the terminal block and earth tab connections ensuring there are no excess wire loops inside the front cover.

Connections for twin element heaters

Twin element heaters are wired for non simultaneous operation. A flexible 20 mm conduit is required for the electrical cable to the storage cylinder. All wiring passes through the lower entry. The conduit is to be connected to the unit with a 20 mm terminator. A common neutral is used. Connect the power supply wires directly to the terminal block and earth tab connections ensuring there are no excess wire loops inside the front cover.

Heating Element Thermostat Temperature Settings

Australian Standards require a minimum thermostat set point of 60°C to inhibit the growth of Legionella Pneumophila bacteria. These standards also require that the thermostat set point of water heaters fitted with an upper (or booster) element is at least 10°C below the thermostat set point of the lower element.

In the interests of durability, the thermostat set point for storage cylinders should not exceed 70°C. Hence, in systems with a single heating element only the thermostat set point should be at least 60°C and no greater than 70°C. In systems with both a lower and upper (or booster) element, the thermostat set point of the lower element should be between 60°C and 70°C and the upper element 50°C - 60°C.

For systems using the deluxe controller a setting of 60°C is recommend.



This appliance may deliver water at high temperature. Refer to the Plumbing Code of Australia (PCA), local requirements and installation instructions to determine if additional delivery temperature control is required.

Deluxe Controller



The Deluxe controller is used for systems with an electric element tank with a mid sensor port.

The power supply to a single lower element model should be continuous. It is connected via the control box to allow the Deluxe controller to manage the element operation. Full details of the how to connect the power to the control box are included in the solar controller manual.

Wiring Diagrams

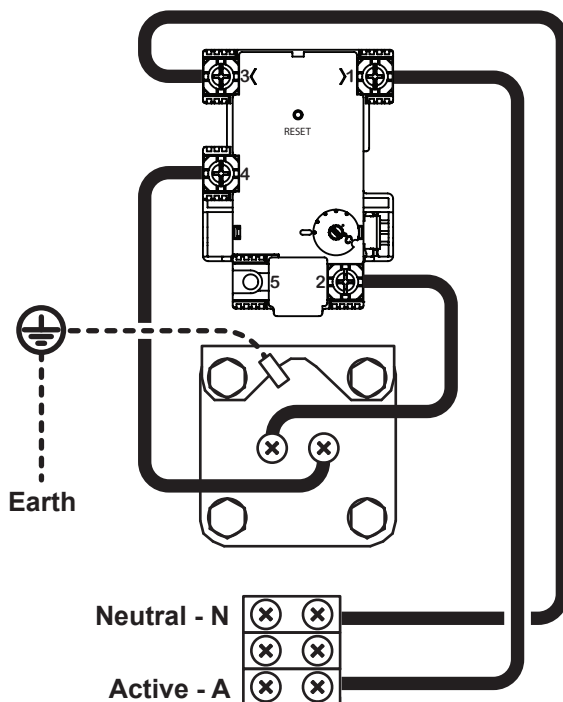

A flexible 20 mm conduit is required for the electrical cable to the solar controller connection box.

The lead between the electric element solar controller connection box is supplied with the controller. The Installer must connect this to the terminal block and earth tab connections on the storage cylinder. Ensure there are no excess wire loops inside the front cover.

FINISHING THE INSTALLATION

1. Remove any cardboard or tarp covers that may have been placed over the solar collectors to prevent them from heating water during installation and commissioning.
2. Activate electrical power to the booster (gas or electric element) and solar pump and controller. Solar heating of the water in the cylinder will now commence when sufficient solar radiation is available.
3. Commission any temperature limiting devices in accordance with the instructions supplied by the manufacturer.
4. Confirm the hot water delivery temperature at a tempered water outlet. Tempered water outlets should be those supplying areas primarily used for the purposes of personal hygiene such as bathrooms. The hot water delivery temperature should not exceed 50°C or 45°C as detailed in the section 'Hot Water Delivery Temperature' on page 21.
5. Explain to the householder the functions and operation of solar water heater components and the importance of carrying out maintenance as per separate warranty document.
6. Leave this manual and the warranty booklet with the householder.

DRAINING INSTRUCTIONS

1. The power supply to the gas booster and pump controller must be switched off and fuse(s) removed.
2. Close the cold water mains supply stop cock.
3. Open a hot tap to relieve pressure.
4. Disconnect the hot outlet near the top of the storage cylinder.
5. Disconnect the cold inlet near the bottom of the storage cylinder.
6. Disconnect the connection between the solar 'flow pipe' and solar pump.
7. Disconnect the connection between the solar 'return pipe' and the cylinder.
8. The cylinder and solar collectors will now drain completely

NOTES



Rinnai Australia Pty Ltd

ABN 74 005 138 769 | AU45204

100 Atlantic Drive, Keysborough, Victoria 3173
P.O. Box 460, Braeside, Victoria 3195
Tel: (03) 9271 6625

National Help Line

Tel: 1300 555 545*

Monday to Friday, 8.00 am to 5.00 pm EST.

After Hours Hot Water Service Line

Tel: 1800 000 340*

**Cost of a local call may be higher from a mobile phone.
(National calls from public phones in Australia are free.)*

For further information visit **www.rinnai.com.au**
or email **enquiry@rinnai.com.au**

Rinnai has a Service and Spare Parts network with personnel who are fully trained and equipped to give the best service on your Rinnai appliance. If your appliance requires service, please call our National Help Line. Rinnai recommends that this appliance be serviced every 2 years.

With our policy of continuous improvement, we reserve the right to change, or discontinue at any time, specifications or designs without notice.